

**EN** WINE COOLER/BEVERAGE CENTER  
**FR** REFROIDISSEUR DE VIN/ CENTRE  
DE BOISSONS  
**ES** REFRIGERADOR DE VINO/ CENTRO  
DE BEBIDAS

USE AND CARE GUIDE  
GUIDE D'UTILISATION ET D'ENTRETIEN  
GUIA DE USO Y CUIDADO



## 2 Finding Information

### Please Read and Save This Guide

Thank you for choosing Electrolux, the new premium brand in home appliances. This Use & Care Guide is part of our commitment to customer satisfaction and product quality throughout the service life of your new Wine Cooler/Beverage Center.

We view your purchase as the beginning of a relationship. To ensure our ability to continue serving you, please use this page to record key product information.



#### IMPORTANT

PLEASE READ all instructions completely before attempting to install or operate the unit.

All Wine Cooler/Beverage Centers require a connection to an electrical power source. Improper hook-up can result in a safety hazard and potential damage to the product or contents! Proper installation, in accordance with the manufacturer's specifications and all local codes, is the sole responsibility of the consumer. The manufacturer is not responsible for any installation expenses or damages incurred due to improper installation. If you are unsure of your ability to safely connect electric power to the unit, consult a licensed and insured professional to perform all electrical work.

Once you have your unit installed, we suggest you keep this manual in a safe place for future reference. Should any problems occur, refer to the "Troubleshooting" section of this manual. This information will help you quickly identify a problem and get it remedied. In the event you require assistance, please contact the dealer where you purchased your unit.

### Make a Record for Quick Reference

Whenever you call to request information or service, you will need to know your model number and serial number. You can find this information on the serial plate located in the top left hand corner of your unit and on the product registration card.



#### NOTE

Registering your product with Electrolux enhances our ability to serve you. You can register online at [www.electroluxappliances.com](http://www.electroluxappliances.com) or by dropping your Product Registration Card in the mail. Complete and mail the Product Registration Card as soon as possible to validate the registration date.

### Product Registration Card

The package containing this manual also includes your product registration information. Warranty coverage begins at the time your Electrolux wine cooler was purchased.

Please record the purchase date of your Electrolux unit and your dealer's name, address and telephone number.

\_\_\_\_\_  
Purchase Date

\_\_\_\_\_  
Electrolux Model Number

\_\_\_\_\_  
Electrolux Serial Number

\_\_\_\_\_  
Dealer Name

\_\_\_\_\_  
Dealer Address

\_\_\_\_\_  
Dealer Telephone

Keep this manual and the sales receipt together in a safe place for further reference.

## Questions?

For toll-free telephone support in the U.S. and Canada: 1-877- 4ELECTROLUX (1-877-435-3287)

For online support and Internet product information: [www.electroluxappliances.com](http://www.electroluxappliances.com)

## Table of Contents

Finding Information .....	2
Safety .....	4
Feature Overview .....	7
Installation .....	8
Leveling .....	14
Operation .....	15
Door Reversal .....	18
Storage .....	20
Care & Maintenance .....	21
Troubleshooting .....	22
Warranty Information .....	23
Quebec Right to Repair .....	24

# 4 Safety

## Important Safety Instructions

### Safety Precautions

Do not attempt to install or operate your unit until you have read the safety precautions in this manual. Safety items throughout this manual are labeled with a Danger, Warning or Caution based on the risk type.

### Definitions

 This is the safety alert symbol. It is used to alert you to potential personal injury hazards. Obey all safety messages that follow this symbol to avoid possible injury or death.



### DANGER

DANGER indicates an imminently hazardous situation which, if not avoided, will result in death or serious injury.



### WARNING

WARNING indicates a potentially hazardous situation which, if not avoided, could result in death or serious injury.



### CAUTION

CAUTION indicates a potentially hazardous situation which, if not avoided, may result in minor or moderate injury.



### IMPORTANT

Indicates installation, operation, or maintenance information which is important but not hazard-related.

## General Precautions



### WARNING

**RISK OF CHILD ENTRAPMENT.** Before you throw away your old appliance, take off the doors and leave shelves in place so that children may not easily climb inside.



### WARNING

- Never attempt to repair or perform maintenance on the unit until the electricity has been disconnected.
- Altering, cutting of power cord, removal of power cord, removal of power plug, or direct wiring can cause serious injury, fire and/or loss of property and/or life and will void the warranty.
- Do not lift unit by door handle.



### CAUTION

- Use care when moving the unit. Some edges are sharp and may cause personal injury. Wear gloves when moving or repositioning the unit.
- Never install the unit behind closed doors. Be sure front grille is free of obstruction. Obstructing free air flow can cause the unit to malfunction, and may void the warranty.
- Allow unit temperature to stabilize for 24 hours before use.



### CAUTION

Use only genuine Electrolux replacement parts. Imitation parts can damage the unit and may void the warranty.



### WARNING

**WARNING! CALIFORNIA RESIDENTS**  
Cancer and Reproductive Harm  
[www.P65Warnings.ca.gov](http://www.P65Warnings.ca.gov)



## DANGER



DANGER Risk of fire or explosion. Flammable refrigerant used. Do not use mechanical devices to defrost refrigerator. Do not puncture refrigerant tubing.

DANGER Risk of fire or explosion. Flammable refrigerant used. To be repaired only by trained service personnel. Do not puncture refrigerant tubing.

- airtight chambers, and can quickly cause suffocation.
- Remove all staples from the carton. Staples can cause severe cuts, and destroy finishes if they come in contact with other appliances or furniture.
- An empty, discarded Wine Cooler/Beverage Center is a very dangerous attraction to children.
- Remove the door(s) of any appliance that is not in use, even if it is being discarded.



## CAUTION



CAUTION Risk of fire or explosion. Flammable refrigerant used. Consult repair manual/owner's guide before attempting to service this product. All safety precautions must be followed.

CAUTION Risk of fire or explosion. Dispose of property in accordance with federal or local regulations. Flammable refrigerant used.

CAUTION Risk of fire or explosion due to puncture of refrigerant tubing. Follow handling instructions carefully. Flammable refrigerant used.

### Proper Disposal of your Wine Cooler/Beverage Center

#### Risk of child entrapment

Child entrapment and suffocation are not problems of the past. Junked or abandoned Wine Coolers/Beverage Centers are still dangerous – even if they will sit for “just a few days”. If you are getting rid of your old unit, please follow the instructions below to help prevent accidents.

We strongly encourage responsible appliance recycling/disposal methods. Check with your utility company or visit [www.recyclemyoldfridge.com](http://www.recyclemyoldfridge.com) for more information on recycling your old Wine Cooler/Beverage Center.

#### Before you throw away your old Wine Cooler/Beverage Center:

- Remove doors.
- Leave shelves in place so children may not easily climb inside.
- Have refrigerant removed by a qualified service technician.



## WARNING

Do not use electrical appliances inside the food storage compartments of the appliance, unless they are of the type recommended by the manufacturer.

### Child Safety

- This appliance is not intended for use by persons (including children) with reduced physical, sensory or mental capabilities, or lack of experience and knowledge, unless they have been given supervision or instruction concerning use of the appliance by a person responsible for their safety.
- Destroy carton, plastic bags, and any exterior wrapping material immediately after the Wine Cooler/Beverage Center is unpacked. Children should never use these items to play. Cartons covered with rugs, bedspreads, plastic sheets or stretch wrap may become

# 6 Safety

## Electrical Information

- The Wine Cooler/Beverage Center must be plugged into its own dedicated 115 Volt, 60 Hz., 15 Amp, AC only electrical outlet. The power cord of the appliance is equipped with a three-prong grounding plug for your protection against electrical shock hazards. It must be plugged directly into a properly grounded three prong receptacle. The receptacle must be installed in accordance with local codes and ordinances. Consult a qualified electrician. Avoid connecting refrigerator to a Ground Fault Interruptor (GFI) circuit. Do not use an extension cord or adapter plug.
- If the power cord is damaged, it should be replaced by an authorized service technician to prevent any risk.
- Never unplug the wine cooler by pulling on the power cord. Always grip the plug firmly, and pull straight out from the receptacle to prevent damaging the power cord.
- Unplug the Wine Cooler/Beverage Center before cleaning and before replacing a light bulb to avoid electrical shock.
- Performance may be affected if the voltage varies by 10% or more. Operating the Wine Cooler/Beverage Center with insufficient power can damage the compressor. Such damage is not covered under your warranty.
- Do not plug the unit into an electrical outlet controlled by a wall switch or pull cord to prevent the Wine Cooler/Beverage Center from being turned off accidentally.

Grounding type wall receptacle

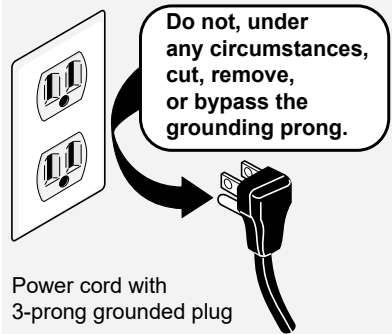

This appliance is intended to be used in household and similar applications such as:

- Staff kitchen areas in shops, offices and other working environments
- Farm houses and by clients in hotels, motels and other residential type environments
- Bed and breakfast type environments
- Catering and similar non-retail applications
- The appliance shall not be exposed to rain

### To connect your unit:

- 1 Locate Power cord box inside unit.
- 2 Remove Power cord from box and insert the plug into the electrical box on the back of the appliance.
- 3 Connect the plug to electrical source.

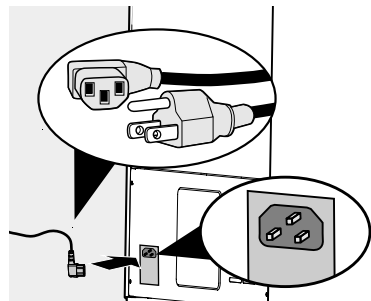

## Beverage Center

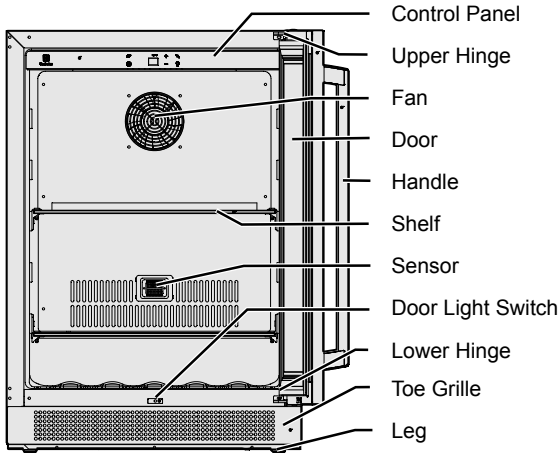

## Wine Cooler

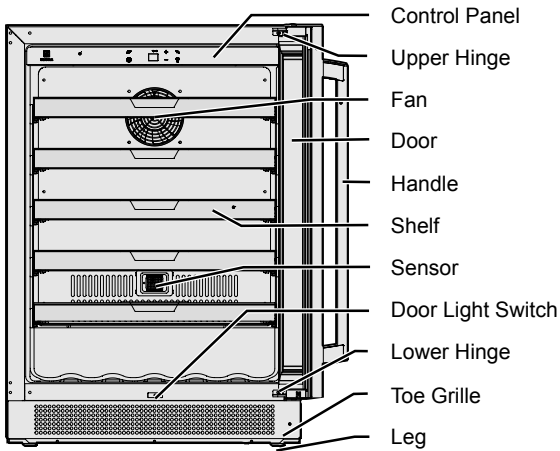

# 8 Installation

## Installation of Your Wine Cooler / Beverage Center

Your Electrolux Wine Cooler/Beverage Center has been designed for either free-standing or under counter installation. When under counter, your unit does not require additional air space for top, sides or rear. In either case, the front grille must NOT be obstructed.

- This appliance is designed to be for free standing installation or under counter (fully recessed). (Refer to sticker located on the back of this appliance.)
- This appliance is intended to be used exclusively for the storage of wine or beverages.
- Place your Wine Cooler/Beverage Center on a floor that is strong enough to support it when it is fully loaded. To level your Wine Cooler/Beverage Center, adjust the front leveling legs at the bottom of the unit.
- This appliance uses flammable refrigerant. So never damage the cooling pipe work during the transportation.
- Locate the Wine Cooler/Beverage Center away from direct sunlight and sources of heat (stove, heater, radiator, etc.). Direct sunlight may affect the acrylic coating and heat sources may increase electrical consumption. Extreme cold ambient temperatures may also cause the unit not to perform properly.
- Avoid locating the unit in moist areas.
- Plug the Wine Cooler/Beverage Center into an exclusive, properly installed, grounded wall outlet. Do not under any circumstances cut or remove the third (ground) prong from the power cord. Any questions concerning power and/or grounding should be directed toward a certified electrician or an Authorized Products Service Center.



### NOTE

To ease unit installation and removal, it is recommended that the cabinet rough opening dimensions be increased by at least ¼ inch over the dimensions given for your unit.



### NOTE

All units require zero clearance when installed flush with a cabinet or wall. Electrolux stainless steel models require a minimum 2-7/8 inch handle clearance when installed against a wall or cabinet that extends beyond the front edge of the unit.

### Before Using Your Wine Cooler/ Beverage Center

- Remove the exterior and interior packing.
- Before connecting the Wine Cooler / Beverage Center to the power source, let it stand upright for approximately 2 hours. This will reduce the possibility of a malfunction in the cooling system from handling during transportation.
- Clean the interior surface with lukewarm water using a soft cloth.

### Using your Wine Cooler/Beverage Center

- Store wine in sealed bottles.
- Do not overload the cabinet.
- Do not open the door unless necessary.
- Do not cover shelves with aluminum foil or any other shelf material which may prevent air circulation.

## Installing the Anti-Tip Bracket



### CAUTION

If your Wine Cooler/Beverage Center is not located under a counter top (free standing), you must use an anti-tip bracket installed as per these instructions. If the Wine Cooler/Beverage Center is removed from its location for any reason, make sure that the bracket is properly engaged when you push the Wine Cooler/Beverage Center back into the original location. If the bracket is not properly engaged, there is a risk of the Wine Cooler/Beverage Center tipping over, causing property or personal injury if you or a child stand, sit, or lean on an open shelf.



### CAUTION

Any finished flooring should be protected with appropriate material to avoid damage when moving the unit.



### WARNING

- ALL UNITS CAN TIP
- INJURY COULD RESULT
- INSTALL ANTI-TIP BRACKET PACKED WITH UNIT
- SEE INSTRUCTIONS



### Tools you will need:



Safety goggles



Stud finder

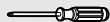

Screwdriver



Gloves



Hammer or Mallet

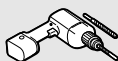

Electric drill with 3/8" drill bit



Wrench



### NOTE

While performing installation described in this section, gloves, safety glasses, or goggles should be worn.



### WARNING

This appliance may tip when shelves are extended, causing damage or injury. If this appliance is used in a FREE STANDING application, the anti-tip bracket must be installed following these instructions!



### IMPORTANT

Determine the final location of the appliance before attempting to install the bracket. You will need to choose one of the three installation methods below.

### Installation methods:

1. DRYWALL
2. WOOD FLOOR
3. CONCRETE FLOOR

### Anti-tip bracket installation

The bracket can be installed at the left bottom OR right bottom of the back of the unit. You can choose which side is convenient for you.

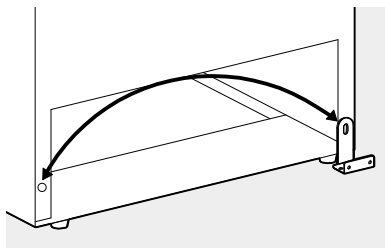

# 10 Installation

## DRYWALL installation:

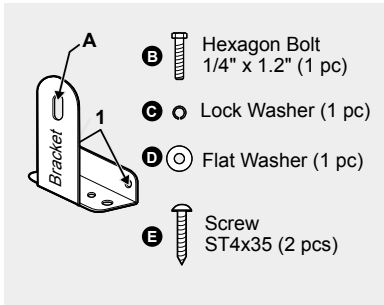

1. After you have chosen the installation location, place the bracket on the floor with (1) against the wall, use Screw (E) (2 pcs) to secure the bracket to the wall. Ensure at least one screw is secured into a stud.
2. Align lower corner of unit and bracket slot (A), secure with hexagon bolt (B), lock washer (C) and flat washer (D).

### IMPORTANT

The screws **MUST** enter into a wood stud. If the wall contains metal studs or similar materials, then the floor installation must be used.

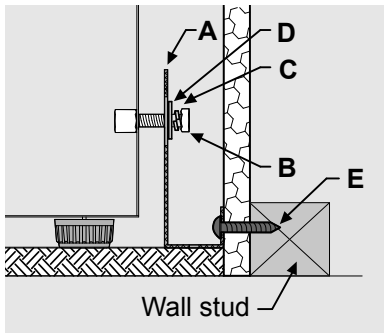

## WOOD FLOOR installation:

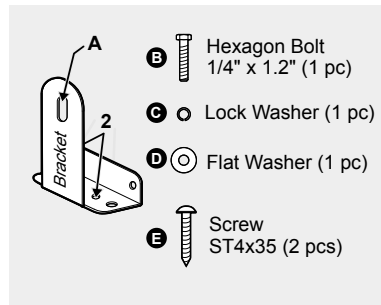

1. After you have chosen the installation location, place the bracket on the wood floor. Use Screw (E) (2 pcs) to secure bracket to floor using bracket holes (2).
2. Align lower corner of unit and bracket slot (A), secure with hexagon bolt (B), lock washer (C) and flat washer (D).

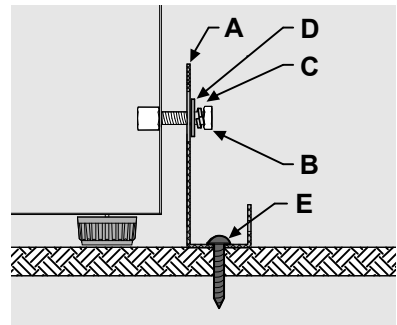

## CONCRETE FLOOR installation:

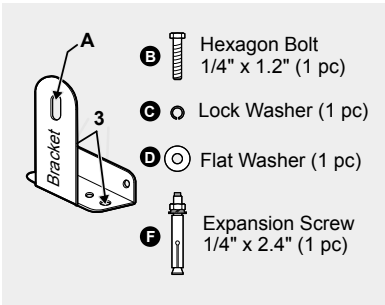

1. After you have chosen the installation location, use either hole (3) to secure the bracket into the concrete floor.
2. Using a concrete bit, drill 8mm (3/8") pilot hole 45mm (1.7") deep.
3. Remove the nut, lock washer and washer from the expansion screw (F).
4. Carefully tap the expansion screw into the concrete, using a hammer or mallet.
5. Align bracket hole (3) over the expansion screw threads and replace washer (D), lock washer (C) and nut back on the expansion screw. Fasten bracket to the floor by tightening nut securely.
6. Align lower corner of unit and bracket slot (A), secure with hexagon bolt (B), lock washer (C) and flat washer (D).

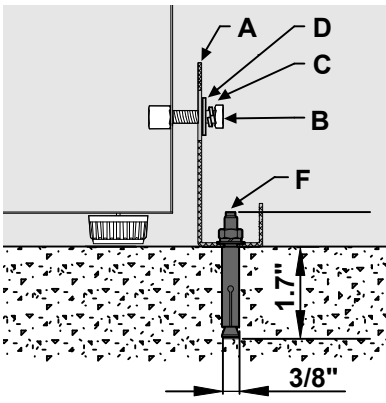

## NOTE

If installing on a concrete floor, concrete fasteners are required, (not included with the anti-tip kit).



## WARNING

**TIP OVER HAZARD:** One of the rear cabinet leveling legs must be engaged under an anti-tip bracket.



## WARNING

After installing the bracket, try using light force to tip the unit. If the unit does not tip then the bracket is mounted securely. If the unit does tip, the bracket **MUST** be reinstalled following these instructions.

# 12 Installation

## Installing the Wine Cooler

Your Electrolux wine cooler has been designed for either free-standing or under counter installation. When under counter, your wine cooler does not require additional air space for top, sides or rear. In either case, the front grille must NOT be obstructed.

### NOTE

To ease unit installation and removal, it is recommended that the cabinet rough opening dimensions be increased by at least  $\frac{1}{4}$  inch over the dimensions given for your unit.

### NOTE

A minimum of  $2\frac{7}{8}$  inch handle clearance is recommend for stainless steel models when installed against a wall or cabinet for door opening/removal of shelves.

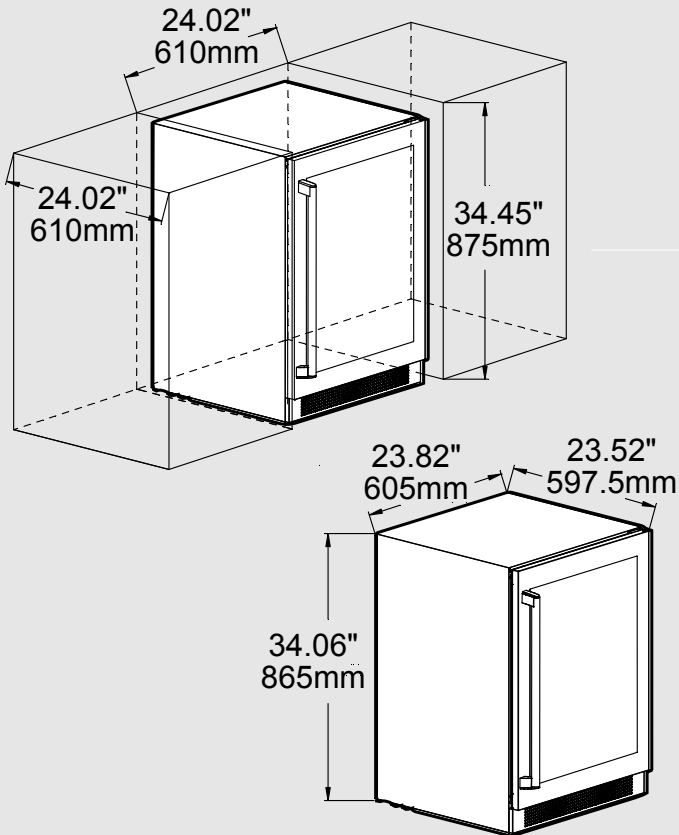

## Anti-Tip Installation for Under Counter

### Installation Instructions

1. Remove the anti-tip bracket and screws from the accessory bag.



### NOTE

If the door is being reversed, please take out the hole plugs from the right hinge holes.

2. Attach the anti-tip bracket with screws (2 pcs) in size M5 (12mm) onto the left hinge holes (if the door is being reversed, please fix the anti-top bracket onto the right hinge holes) and then attach the other end of the anti-tip bracket onto the niche with the screws (2 pcs) in size ST4 (12mm).



### NOTE

If the door is being reversed, please attach the anti-tip bracket onto the right hinge holes and then attach the other end of the anti-tip bracket onto the niche with the screws (2 pcs) in size ST4 (12mm).

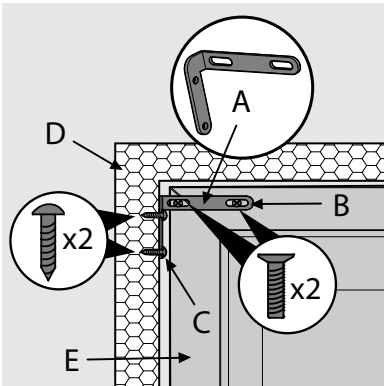

## Handle Installation

### Installation Instructions

1. Place handle over the two mounting screws (A).
2. Use Allen wrench to tighten 2 set screws (B) on handle.

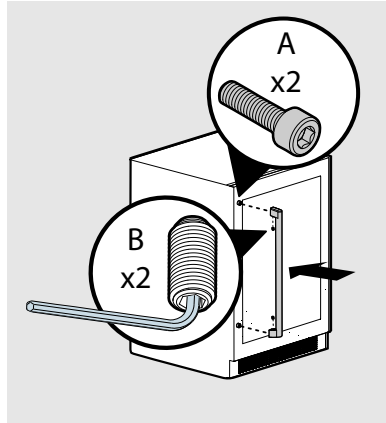

A	Anti-tip bracket (one for right installation and one for left installation)
B	Screws (2 pcs) Size M5 (12mm)
C	Screws (2 pcs) Size ST4 (12mm)
D	Kitchen niche
E	Product cabinet

# 14 Leveling

## Leveling the Unit

Position the unit on a flat, level surface capable of supporting the entire weight of the unit when full.

### Leveling Legs

Adjustable legs at the front and rear corners of the appliance should be set so the unit is firmly positioned on the floor and level from side to side and front to back. The overall height of your Electrolux appliance may be adjusted between the minimum, 33  $\frac{3}{4}$ " (85.7cm), by turning the leveling leg in and the maximum, 34  $\frac{3}{4}$ " (88.3cm), by turning the leveling leg out.

To adjust the leveling legs, place the appliance on a solid surface and protect the floor beneath the legs to avoid scratching the floor. With the assistance of another person, lean the appliance back to access the front leveling legs. Raise or lower the legs to the required dimension by turning the legs. Repeat this process for the rear by tilting the appliance forward using caution. On a level surface check the appliance for levelness and adjust accordingly.

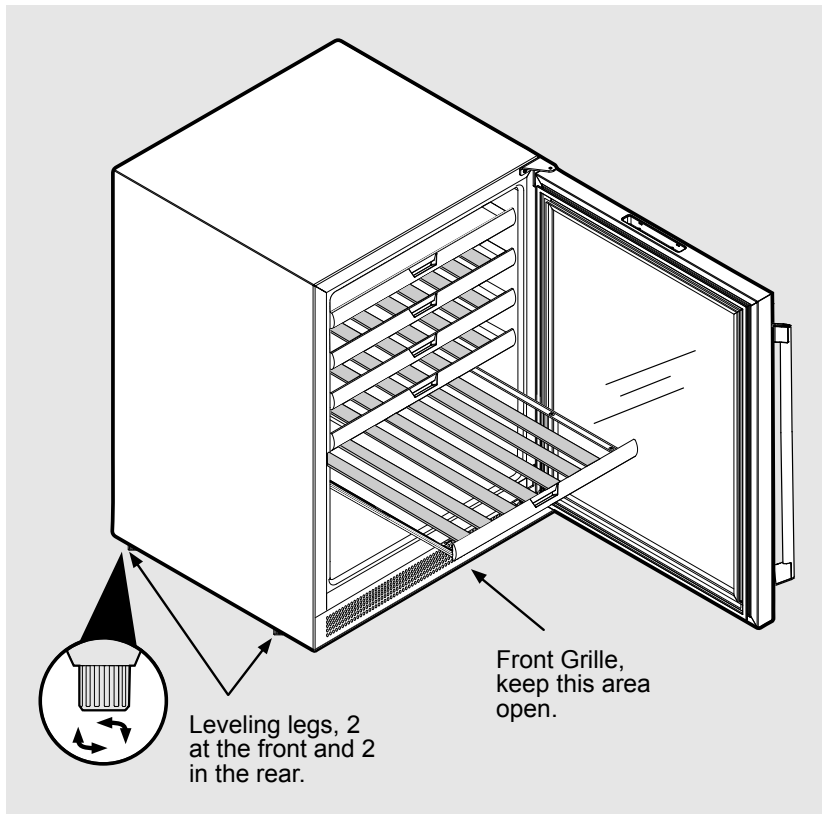

## Wine Cooler



## Beverage Center



### Power On/Off (Wine Cooler)

Simultaneously press and hold the Cellar Mode button and the plus button for 5 seconds to turn the unit power off or on. When the power is turned back on, the display will show the previous temperature settings.



### Power On/Off (Beverage Center)

Press and hold the power button for 3 seconds.

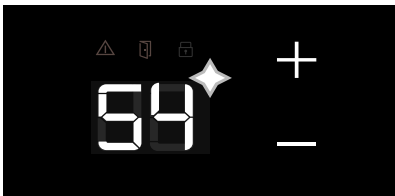

### Temperature Set

Press to decrease/increase the set temperature. Only the set temperature will be shown.



### NOTE

Set temperature is shown while the temperature is being changed. Once complete, current temperature will show on display.



### Lights On/Off

Press once to toggle the lights ON/OFF. Press and hold for 3 seconds to modify the light settings, changing between 2 settings. If the current default setting is '1A', press and hold for 3 seconds and the display will show the '2A' light setting. Press and hold again to set it back. The new setting will display for 2 seconds, then return to show the set temperature.

### Lights Behavior

Temperature display shows the light setting code:



1A: Lights always ON when door is open; Light always OFF when door is closed.



2A: Lights always ON no matter if door is open or closed.

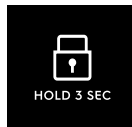

### Child Lock

Press and hold for 3 seconds to activate/deactivate child lock.

Child lock is lit-up when activated.

Child lock disables all button controls. While in the locked state, you will not be able to change any display settings until child lock is deactivated.

## 16 Operation



### Sabbath Mode

Simultaneously press and hold the increase temperature and decrease temperature set buttons for 10 seconds to activate/deactivate Sabbath mode.

When activated, temperature display shows "Sb" until it is deactivated.

While in Sabbath mode:

- Any button command is disabled apart from the increase temperature set & decrease temperature set combination command to deactivate the Sabbath mode.
- All lights are turned Off - apart from "Sb".
- Opening or closing the door will not turn on or off any lights, digital readouts, solenoids, fans, valves, compressor, icons, tones, or alarms. There is a 30 second delay from when the door is opened until the compressor is allowed to start or change speed.



Exception: The High/Low Temperature alerts will be displayed in case of high or low temperature inside the appliance. The alert icon turns On, but will not blink, and it will remain until the Sabbath Mode is deactivated. An audio alarm will sound and automatically turn off after 10 minutes.

When deactivated, temperature display shows the previous set temperature.

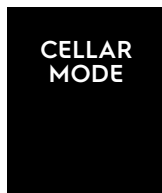

### Cellar Mode Set (Wine Cooler Only)

Press once to toggle on and off the cellar mode.

If the mode is set to Cellaring, the temperature display shows "CE" until the Cellaring mode is deactivated. When deactivated, the previous temperature is shown.

In Cellaring mode, the temperature is fixed and cannot be changed from 12°C/54°F.



### NOTE

Cellar mode temperature is the recommended temperature for longer term storage of wine.

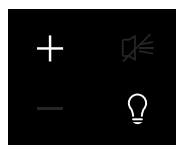

### C°/F° set

To toggle between C° and F° settings, simultaneously press and hold the increase button and the light button.

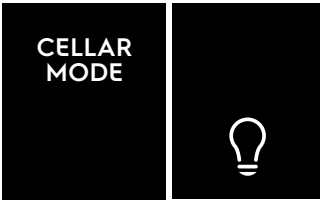

### Demo mode (Wine Cooler)

Simultaneously press and hold the Cellar Mode & light buttons for 10 seconds to activate/deactivate Demo mode



When activated, the display shows alternatively "dE" and "On" for 10 seconds. Any alert turns off temporarily.

To keep communicating that the machine is in Demo mode, every few minutes the display shows alternatively "dE" and "On" for 10 seconds.



When deactivated, the display shows alternatively "dE" and "OF" for 10 seconds.

### Demo mode (Beverage Center)

Simultaneously press and hold the Mute Sounds & light buttons for 10 seconds to activate/deactivate Demo mode



### Mute sounds

Press once to activate/deactivate. Note that alarms will not be muted.



The default setting for sounds is On. Press the mute button once to toggle the display between 'OF' and 'On'.



The 'OF' or 'On' will display for 2 seconds then the display switches back to the previous temperature setting.

When mute sounds is activated, the key presses are muted, the alarms will still be active.



### High / Low temperature alert

When the set temp has been exceeded during a period of 6 hours, High Temperature alert shows "H" and blinks the alert icon.



When the set temp has been insufficient during a period of 6 hours, Low Temperature alert shows "L" and blinks the alert icon.

The alerts will not sound in the first 90 minutes after power on.



### Door open alert

If the door is left open for 5 minutes or more, the door open icon turns On, the lights start to blink and an alarm sounds.

Any interaction on the Control panel will disable the alarms. The icon stays on as long the door is open.

# 18 Door Reversal

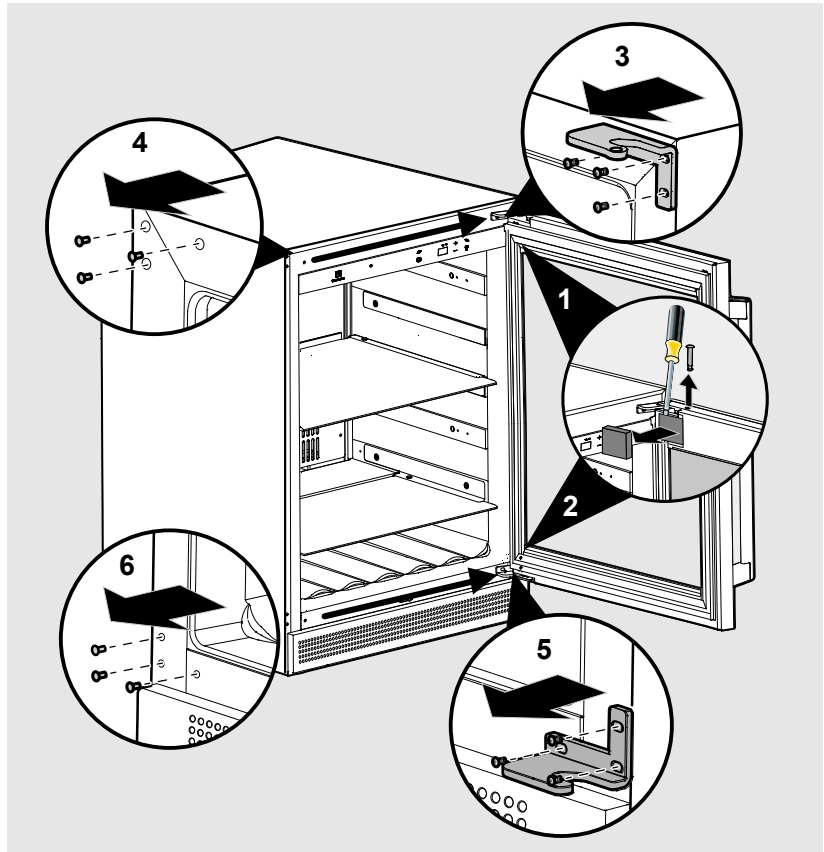

## Reversing the Door

1. To remove the top hinge pin, open the door and pull down the gasket. Use a flat screwdriver to pry the hook out then push up on top hinge pin.
2. Repeat to remove the bottom hinge pin. Remove door and place on a padded surface to prevent damage.

3. Remove the top hinge screws using a Phillips head screwdriver.
4. Carefully remove the top screw hole plugs and move to the opposite side.
5. Remove the lower hinge screws using a Phillips head screwdriver.
6. Carefully remove the lower screw hole plugs and move to the opposite side.



## CAUTION

Doors are heavy. Two people are recommended to remove or replace the door assembly from the cabinet.

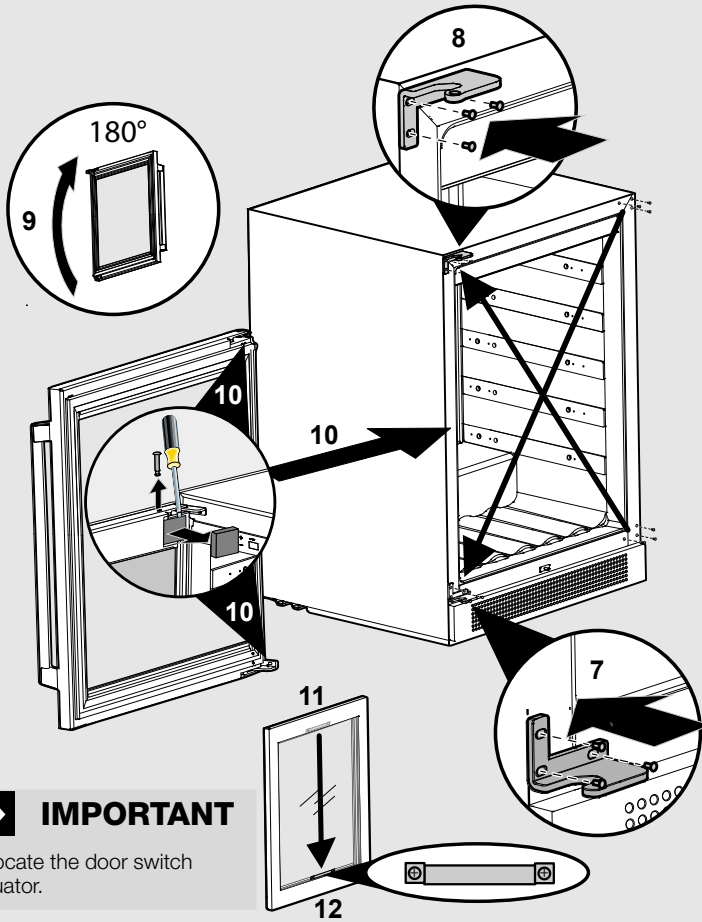

## IMPORTANT

Relocate the door switch actuator.

7. Install the right top hinge on the left lower corner.
8. Install the right lower hinge on the left top corner.
9. Rotate the door 180 degrees (handle on the right side). Place door on the left lower hinge. Install the hinge pin hook then install the hinge pin.
10. Align the door and top hinge. Install the hinge pin hook then install the hinge pin.
11. The actuator is on the inside top of the door and should be relocated to the bottom of the door.
12. Replace the 2 screws where the actuator was located at the top of the door to conceal the remaining holes.



## NOTE

After the door reversal process, make sure the door switch actuator (12) is installed on the inside bottom of the door.

## Wine bottle storage

Only Burgundy and Bordeaux wine bottles can be loaded on the bottom of the wine cooler. All other shelves can load Burgundy, Bordeaux and Champagne wine bottles. Bottle capacity is 41.

### Wine cooler Shelving:

- Five (5) roll-out wine racks

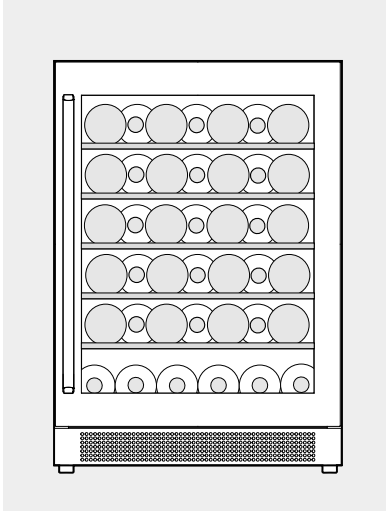

## Shelf Removal

### Wine Cooler

Open the door completely and pull out the shelf to the end. Lift up on the front of the shelf, then on the back part of the shelf pull slightly forward and lift up to disconnect the shelf from the rail.

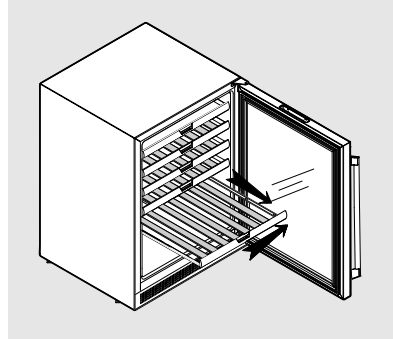

### Beverage Center

Open the door completely and push out the fixing screws on both sides of the shelf. Continue removing the shelf.

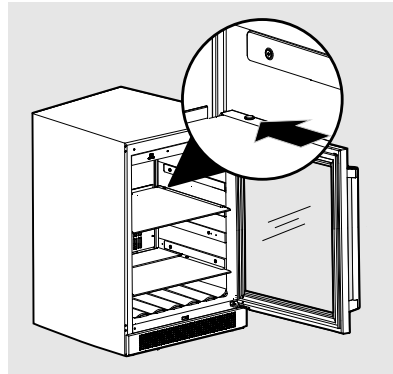

## CAUTION

Never try to remove a loaded shelf, remove everything from the shelf before moving. Use both hands when moving the shelf.

## Maintaining Your Wine cooler

Periodic cleaning and proper maintenance will ensure efficiency, top performance, and long life. The maintenance intervals listed are based on normal conditions. You may want to shorten the intervals if you have pets or other special considerations.

### Exterior Cleaning for Your Stainless Steel Model

- Your stainless steel model may discolor when exposed to chlorine gas, pool chemicals, salt water, or cleaners with bleach.
- Keep your stainless unit looking new by cleaning with a high quality, all-in-one stainless steel cleaner/polish on a monthly basis. Frequent cleaning will remove surface contamination that could lead to rust. Some installations will require cleaning on a weekly basis.
- DO NOT CLEAN WITH STEEL WOOL PADS.
- DO NOT USE CLEANERS THAT ARE NOT SPECIFICALLY INTENDED FOR STAINLESS STEEL (this includes glass, tile and counter cleansers).
- If any surface discolors or rusting appears, clean it quickly with Bon-Ami or Barkeepers Friend Cleanser and a non-abrasive cloth. Always clean in the direction of the grain. Always finish this process with a high quality, all-in-one stainless steel cleaner/polish to prevent further problems.
- USE OF ABRASIVE PADS SUCH AS SCOTCHBRITE WILL CAUSE THE GRAINING IN THE STAINLESS TO BECOME BLURRED.
- Rust that is allowed to linger can penetrate into the surface of the stainless steel and become impossible to remove.



### CAUTION

- Stainless steel models exposed to chlorine gas and moisture such as areas with spas or swimming pools, may have some discoloration of the stainless steel. Discoloration from chlorine gas is normal. Follow exterior cleaning instructions.
- NEVER USE CHLORIDE OR CLEANERS CONTAINING BLEACH TO CLEAN STAINLESS STEEL.

### Interior Cleaning - as Required

- 1 Disconnect power to the wine cooler.
- 2 Remove racks if desired.
- 3 Wipe down the interior with a solution of non-abrasive mild detergent and warm water.
- 4 Rinse with clear water.
- 5 Reconnect power to the unit.

### Should the Wine Cooler/Beverage Center be stored without use for long periods:

- Clean thoroughly.
- Leave the door ajar to allow air to circulate inside the cabinet in order to avoid possible formations of condensation, mold or odors.

# 22 Troubleshooting

## Before You Call for Service If Service is Required

If the unit appears to be malfunctioning, read through this manual first. If the problem persists, check the Troubleshooting Guide below. Locate the problem in the guide and refer to the cause and its remedy before calling for service. The problem may be something very simple that can be solved without a service call. Consulting or contracting a qualified service technician may be necessary.

Contact the dealer where you purchased the unit if service is required. State the model and serial number and explain the problem. The model and serial number plate is located on the ceiling of your unit. If you do not know the name of the selling dealer or a local service company, you can check online at [www.electroluxappliances.com](http://www.electroluxappliances.com) or call 1-877-435-3287.



### WARNING

#### ELECTROCUTION HAZARD

NEVER attempt to repair or perform maintenance on the unit until the main electrical power has been disconnected.

Problem	Possible Cause	Remedy
Unit not cold enough. Adjust temperatures (see "Adjusting the Temperature" in the "Start-Up and Temperature Control" section).	<ul style="list-style-type: none"><li>Control set too warm.</li><li>Light staying on.</li><li>Airflow to front grille blocked.</li><li>Door gasket not sealing properly.</li></ul>	<ul style="list-style-type: none"><li>Adjust temperature colder. Allow 24 hours for temperature to stabilize.</li><li>Turn off manual light control. See "<b>Operation</b>" section.</li><li>Airflow must not be obstructed to front grille. See "<b>Installation</b>" section.</li><li>Adjust door gasket.</li></ul>
Unit too cold. Contents of unit too cold/frozen. Adjust temperatures (see "Adjusting the Temperature" in the "Start-Up and Temperature Control" section).	<ul style="list-style-type: none"><li>Control set too cold.</li></ul>	<ul style="list-style-type: none"><li>Adjust temperature warmer. Allow 24 hours for temperature to stabilize.</li></ul>
No interior light.	<ul style="list-style-type: none"><li>Failed LED assembly.</li></ul>	<ul style="list-style-type: none"><li>Contact a qualified Electrolux Service Technician.</li></ul>
Light will not go out when door is closed.	<ul style="list-style-type: none"><li>Manual light control is ON.</li><li>Door switch not making contact.</li></ul>	<ul style="list-style-type: none"><li>Turn off manual light control. See "Operation" section.</li><li>Check for proper door alignment.</li></ul>
Alarm(s) will not shut off.	<ul style="list-style-type: none"><li>Door is ajar.</li><li>Power has failed.</li><li>Internal temperature is too high.</li></ul>	<ul style="list-style-type: none"><li>Press "Alarm" key to acknowledge alarm.</li><li>Ensure door is closed firmly.</li><li>Allow 24 hours for temperature to stabilize.</li></ul>
Power is not restored after power failure.	<ul style="list-style-type: none"><li>Circuit breaker has tripped.</li></ul>	<ul style="list-style-type: none"><li>Verify electrical supply. See "Installation" section.</li></ul>
Door does not close properly.	<ul style="list-style-type: none"><li>Door hinges are misaligned.</li><li>Door gasket is not sealing properly.</li></ul>	<ul style="list-style-type: none"><li>Loosen hinges and re-align door. Retighten hinges.</li><li>Turn gasket 180°.</li></ul>

## Major Appliance Warranty Information

Your appliance is covered by a one year limited warranty. For one year from your original date of purchase, Electrolux will repair or replace any parts of this appliance that prove to be defective in materials or workmanship when such appliance is installed, used, and maintained in accordance with the provided instructions. In addition, the cabinet liner and sealed refrigeration system (compressor, condenser, evaporator, dryer or tubing) of your appliance is covered by a two through five year limited warranty. During the 2<sup>nd</sup> through 5<sup>th</sup> years from your original date of purchase, Electrolux will repair or replace any parts in the cabinet liner and sealed refrigeration system which prove to be defective in materials or workmanship when such appliance is installed, used, and maintained in accordance with the provided instructions.

### Exclusions

***This warranty does not cover the following:***

1. Products with original serial numbers that have been removed, altered or cannot be readily determined.
2. Product that has been transferred from its original owner to another party or removed outside the USA or Canada.
3. Rust on the interior or exterior of the unit.
4. Products purchased "as-is" are not covered by this warranty.
5. Food loss due to any refrigerator or freezer failures.
6. Products used in a commercial setting.
7. Service calls which do not involve malfunction or defects in materials or workmanship, or for appliances not in ordinary household use or used other than in accordance with the provided instructions.
8. Service calls to correct the installation of your appliance or to instruct you how to use your appliance.
9. Expenses for making the appliance accessible for servicing, such as removal of trim, cupboards, shelves, etc., which are not a part of the appliance when it is shipped from the factory.
10. Service calls to repair or replace appliance light bulbs, air filters, water filters, other consumables, or knobs, handles, or other cosmetic parts.
11. Pickup and delivery costs; your appliance is designed to be repaired in the home.
12. Surcharges including, but not limited to, any after hour, weekend, or holiday service calls, tolls, ferry trip charges, or mileage expense for service calls to remote areas, including the state of Alaska.
13. Damages to the finish of appliance or home incurred during transportation or installation, including but not limited to floors, cabinets, walls, etc.
14. Damages caused by: services performed by unauthorized service companies; use of parts other than genuine Electrolux parts or parts obtained from persons other than authorized service companies; or external causes such as abuse, misuse, inadequate power supply, accidents, fires, or acts of God.

### DISCLAIMER OF IMPLIED WARRANTIES; LIMITATION OF REMEDIES

CUSTOMER'S SOLE AND EXCLUSIVE REMEDY UNDER THIS LIMITED WARRANTY SHALL BE REPAIR OR REPLACEMENT AS PROVIDED HEREIN. CLAIMS BASED ON IMPLIED WARRANTIES, INCLUDING WARRANTIES OF MERCHANTABILITY OR FITNESS FOR A PARTICULAR PURPOSE, ARE LIMITED TO ONE YEAR OR THE SHORTEST PERIOD ALLOWED BY LAW, BUT NOT LESS THAN ONE YEAR. ELECTROLUX SHALL NOT BE LIABLE FOR CONSEQUENTIAL OR INCIDENTAL DAMAGES SUCH AS PROPERTY DAMAGE AND INCIDENTAL EXPENSES RESULTING FROM ANY BREACH OF THIS WRITTEN LIMITED WARRANTY OR ANY IMPLIED WARRANTY. SOME STATES AND PROVINCES DO NOT ALLOW THE EXCLUSION OR LIMITATION OF INCIDENTAL OR CONSEQUENTIAL DAMAGES, OR LIMITATIONS ON THE DURATION OF IMPLIED WARRANTIES, SO THESE LIMITATIONS OR EXCLUSIONS MAY NOT APPLY TO YOU. THIS WRITTEN WARRANTY GIVES YOU SPECIFIC LEGAL RIGHTS. YOU MAY ALSO HAVE OTHER RIGHTS THAT VARY FROM STATE TO STATE.

### If You Need Service

Keep your receipt, delivery slip, or some other appropriate payment record to establish the warranty period should service be required. If service is performed, it is in your best interest to obtain and keep all receipts. Service under this warranty must be obtained by contacting Electrolux at the addresses or phone numbers below.

This warranty only applies in the USA, Puerto Rico and Canada. In the USA and Puerto Rico, your appliance is warranted by Electrolux Major Appliances North America, a division of Electrolux Home Products, Inc. In Canada, your appliance is warranted by Electrolux Canada Corp. Electrolux authorizes no person to change or add to any obligations under this warranty. Obligations for service and parts under this warranty must be performed by Electrolux or an authorized service company. Product features or specifications as described or illustrated are subject to change without notice.

## 24 Quebec Right to Repair

---

<https://www.electrolux.ca/EN/OWNER-SUPPORT/RIGHT-TO-REPAIR/>

Though Electrolux makes every effort to make replacement parts, repair services and information necessary to maintain or repair our products available to consumers, parts, service and information are not guaranteed, pursuant to section 39 of the Consumer Protection Act, CQLR, c. P-40.1 and sections 79.18 to 79.20 of the Regulation respecting the application of the Consumer Protection Act, CQLR, c P-40.1, r. 3.

### **USA**

**1-877-435-3287**

Electrolux Consumer  
Products, Inc.,  
North America  
10200 David Taylor Drive  
Charlotte, NC 28262



**Electrolux**

### **Canada**

**1-800-265-8352**

Electrolux Canada Corp.  
5855 Terry Fox Way  
Mississauga, Ontario, Canada  
L5V 3E4