

Refrigerator

User manual

Free Standing Appliance

SAMSUNG

Contents

Safety information	4
What you need to know about the safety instructions	4
Important safety symbols and precautions:	5
State of California Proposition 65 Warning	5
Important safety precautions	5
Severe warning signs for transportation and site	7
Critical installation warnings	7
Installation cautions	9
Critical usage warnings	9
Usage cautions	13
Cleaning cautions	14
Critical disposal warnings	15
Installation	16
Refrigerator at a glance	17
Step-by-step installation	20
Operations	42
Main panel	42
SmartThings	48
SMART GRID Function (Demand Response)	51
Special features	53
Maintenance	67
Handling and care	67
Cleaning	74
Replacement	77
Troubleshooting	80
General	80
Do you hear abnormal sounds from the refrigerator?	86
SmartThings	88
Smart Grid	89

LIMITED WARRANTY (U.S.A.)	90
SAMSUNG REFRIGERATOR	90
Warranty Information (CANADA)	93
If your refrigerator needs service	93
Limited Warranty for Original Purchaser	93
Obligation to the Original Owner	93
Exclusions of the Warranty	94
NOTICE TO QUEBEC CONSUMERS - Warranty of Availability of Replacement Parts, Repair Services, and Maintenance and Repair Information	94
DISCLAIMER OF LIABILITY	95
Regulatory Notice	97
FCC Notice	97
IC Notice	98
Open Source Announcement	99
Open Source Announcement	99

Safety information

Before using your new Samsung Refrigerator, please read this manual thoroughly to ensure that you know how to operate the features and functions that your new appliance offers safely and efficiently.

What you need to know about the safety instructions

- This appliance is not intended for use by persons (including children) with reduced physical, sensory or mental capabilities, or lack of experience and knowledge, unless they have been given supervision or instruction concerning use of the appliance by a person responsible for their safety. Children should be supervised to ensure that they do not play with the appliance.
- Because the following instructions cover various models, the characteristics of your refrigerator may differ slightly from the refrigerator described in this manual.
- If you have any question, contact us at 1-800-SAMSUNG or find help and information online at www.samsung.com.
- Refrigerant squirting out of the pipes could ignite or cause an eye injury. When refrigerant leaks from the pipe, avoid any naked flames and move anything flammable away from the product and ventilate the room immediately.
 - Failing to do so may result in fire or explosion.
- Improper use of the grounding plug can result in a risk of electric shock. If it is necessary to use an extension cord, use only a 3-wire extension cord that has a 3-blade grounding plug and a 3-slot receptacle that will accept the plug on the appliance. The marked rating of the extension cord should be AC 115-120 V, 10 A, or more. If a grounding adapter is used, make sure the receptacle box is fully grounded.

Important safety symbols and precautions:

Please follow all safety instructions in this manual. This manual uses the following safety symbols.

WARNING

Hazards or unsafe practices that may result in **severe personal injury, property damage, and/or death.**

CAUTION

Hazards or unsafe practices that may result in **severe personal injury and/or property damage.**

NOTE

Useful information that helps users understand or benefit from the refrigerator.

These warning signs are here to prevent injury to you and others.

Please follow them carefully.

After reading this section, keep it in a safe place for future reference.

State of California Proposition 65 Warning

WARNING

Cancer and Reproductive Harm - www.P65Warnings.ca.gov.

Important safety precautions



WARNING; Risk of fire / flammable materials

WARNING

- R-600a is used as a refrigerant. This product contains flammable gas (Refrigerant R-600a), contact your local authority in regard to safe disposal of this product.
- In order to avoid the creation of a flammable gas-air mixture if a leak in the refrigerating circuit occurs, the size of the room in which the appliance may be sited depends on the amount of refrigerant used. The room must be 35.3 ft³ in size for every 8 g of R-600a refrigerant inside the appliance.

Safety information

- The installation location should not be exposed to direct sunlight and not placed near any electric appliance or heat source, e.g. stove, oven or hob, radiator, etc.
- If you use two products side by side, for safety reason, be sure to use certified products in explosive gas atmospheres.
- Never start up an appliance showing any signs of damage. If in doubt, consult your dealer.
- If the supply cord is damaged, it must be replaced by the manufacturer, its service agent or similarly qualified persons in order to avoid a hazard.
- The socket must be easily accessible so that the appliance can be quickly disconnected from the supply in an emergency. It must be outside the area of the rear of the appliance.
- Do not store explosive substances such as aerosol cans with a flammable propellant in this appliance.
- New hose-sets supplied with the appliance are to be used and that old hose-sets should not be reused.
- When positioning the appliance, ensure the supply cord is not trapped or damaged.
- Do not locate multiple portable socket-outlets or portable power supplies at the rear of the appliance.

WARNING

- Fill with potable water only.
- Keep ventilation openings, in the appliance enclosure or in the built-in structure, clear of obstruction.
- Do not use mechanical devices or other means to accelerate the defrosting process, other than those recommended by the manufacturer.
- Do not damage the refrigerant circuit.
- Do not use electrical appliances inside the food storage compartments of The appliance, unless they are of the type recommended by the manufacturer.
- Connect to potable water supply only.

WARNING

- Risk of child entrapment. Before you throw away your old refrigerator or freezer:
 - Take off the doors.
 - Leave the shelves in place so that children may not easily climb inside.

This appliance is intended to be used in household and similar applications such as

- staff kitchen areas in shops, offices and other working environments;
- farm houses and by clients in hotels, motels and other residential type environments;
- bed and breakfast type environments;
- catering and similar non-retail applications.

Severe warning signs for transportation and site

WARNING

- When transporting and installing the appliance, care should be taken to ensure that no parts of the refrigerating circuit are damaged.
 - Refrigerant leaking from the pipe work could ignite or cause an eye injury. If a leak is detected, avoid any naked flames or potential sources of ignition and air the room in which the appliance is standing for several minutes.
 - This appliance contains a small amount of isobutane refrigerant (R-600a), a natural gas with high environmental compatibility that is, however, also flammable.

Critical installation warnings

WARNING

- Do not install the refrigerator in a damp location or place where it may come in contact with water.
 - Deteriorated insulation on electrical parts may cause an electric shock or fire.
- Do not place this refrigerator in direct sunlight or expose it to the heat from stoves, room heaters, or other appliances.
- Do not plug several appliances and the refrigerator into the same multiple power strip. The refrigerator should always be plugged into its own individual electrical outlet which has a voltage rating that matches the voltage listed on the refrigerator's rating plate.
 - This provides the best performance and also prevents overloading of house wiring circuits, which could overheat the wires and cause a fire hazard.
- If the wall socket is loose, do not insert the power plug.
 - There is a risk of electric shock or fire.
- Do not use a power cord that has cracks or abrasion damage along its length or at either end.
- Do not bend the power cord excessively or place heavy objects on it.
- Do not pull or excessively bend the power cord.
- Do not twist or tie the power cord.
- Do not hook the power cord over a metal object, place a heavy object on the power cord, insert the power cord between objects, or push the power cord into the space behind the appliance.
- When moving the refrigerator, be careful not to roll over or damage the power cord.
 - This may result in an electric shock or fire.

Safety information

- Never unplug your refrigerator by pulling on the power cord. Always grip the plug firmly and pull straight out from the outlet.
 - Damage to the cord may cause a short-circuit, fire, and/or electric shock.
- Do not install this appliance near a heater or flammable material.
- Do not install this appliance in a location where gas may leak.
 - This may result in an electric shock or fire.
- This refrigerator must be properly located and installed in accordance with the instructions in this manual before you use it.
- Connect the power plug in the proper position with the cord hanging down.
 - If you connect the power plug upside down, the wire can get cut off and cause a fire or electric shock.
- Make sure that the power plug is not crushed or damaged by the back of the refrigerator.
- Keep the packing materials out of reach of children.
 - There is a risk of death from suffocation if a child puts the packing materials on his or her head.
- The appliance must be positioned so that the plug is accessible after installation.
 - Failing to do so may result in an electric shock or fire due to electric leakage.
- Do not install this appliance in a humid, oily or dusty location, or in a location exposed to direct sunlight or to water (rain drops).
 - Deteriorated insulation on electrical parts may cause an electric shock or fire.
- If large amounts of dust or water enter the refrigerator, disconnect the power plug and contact a Samsung Electronics service center.
 - Otherwise there is a risk of fire.
- Do not stand on top of the appliance or place objects (such as laundry, lighted candles, lighted cigarettes, dishes, chemicals, metal objects, etc.) on the appliance.
 - This may result in an electric shock, fire, problems with the product, or injury.
- You need to remove all the protective plastic film before you initially plug the product in.
- Children should be supervised to ensure that they do not play with the snap rings used for door adjustment or the water tube clips.
 - There is risk of death by suffocation if a child swallows a snap ring or water tube clip. Keep the snap rings and water tube clips out of children's reach.
- The refrigerator must be safely grounded.
 - Always make sure that you have grounded the refrigerator before attempting to investigate or repair any part of the appliance. Power leakages can cause severe electric shock.

-
- Never use gas pipes, telephone lines, or other potential lightning attractors as an electrical ground.
 - You must ground the refrigerator to prevent any power leakages or electric shocks caused by current leakage from the refrigerator.
 - Current leakage may result in an electric shock, fire, explosion, or problems with the product.
 - Plug the power plug into the wall socket firmly. Do not use a damaged power plug, damaged power cord, or loose wall socket.
 - This may result in an electric shock or fire.
 - Only a qualified technician or service company should be allowed to change the fuse in the refrigerator.
 - Failing to do so may result in an electric shock or personal injury.

Installation cautions

CAUTION

- Allow sufficient space around the refrigerator and install it on a flat surface.
 - Keep the ventilation space in the appliance enclosure or mounting structure clear of obstructions.
- After you have installed the refrigerator and turned it on, allow the appliance to stand for 2 hours before loading it with food.
- It is strongly recommended you have a qualified technician or service company install the refrigerator.
 - Failing to do so may result in an electric shock, fire, explosion, problems with the product, or injury.
- Overloading one door may make the refrigerator fall, causing physical injury.

Critical usage warnings

WARNING

- Do not insert the power plug into a wall socket with wet hands.
 - This may result in an electric shock.
- Do not store articles on the top of the appliance.
 - When you open or close the door, the articles may fall and cause personal injury and/or material damage.

Safety information

- Do not insert hands, feet, or metal objects (such as chopsticks, etc.) into the bottom or the back of the refrigerator.
 - This may result in an electric shock or injury.
 - Any sharp edges may cause a personal injury.
- Do not touch the inside walls of the freezer or products stored in the freezer with wet hands.
 - This may cause frostbite.
- Do not put a container filled with water on the refrigerator.
 - If spilled, there is a risk of fire or electric shock.
- Do not keep volatile or flammable objects or substances (benzene, thinner, propane gas, alcohol, ether, LP gas, and other such products) in the refrigerator.
 - This refrigerator is for storing food only.
 - This may result in fire or explosion.
- Children should be supervised to ensure that they do not play with the appliance.
 - Keep fingers out of “pinch point” areas. Clearances between the doors and cabinet are necessarily small. Be careful when you open the doors if children are in the area.
- Do not let children hang on the door or door bins. A serious injury may occur.
- Do not let children go inside the refrigerator. They could become trapped.
- Do not insert your hands into the area under the appliance.
 - Any sharp edges may cause personal injury.
- Do not store pharmaceutical products, scientific materials, or temperature sensitive products in the refrigerator.
 - Products that require strict temperature controls must not be stored in the refrigerator.
- Do not place or use electrical appliances inside the refrigerator/freezer, unless they are of a type recommended by the manufacturer.
- If you smell smoke, pull out the power plug immediately, and then contact a Samsung Electronics service center.
- If large amounts of dust or water enter the refrigerator, disconnect the power plug and contact your Samsung Electronics service center.
 - Otherwise there is a risk of fire.
- Do not let children step on a drawer.
 - The drawer may break and cause them to slip.
- Do not leave the doors of the refrigerator open while the refrigerator is unattended and do not let children enter the refrigerator.
- Do not allow babies or children to go into a drawer.
 - It can cause death from suffocation by entrapment or personal injury.

-
- Do not overfill the refrigerator with food.
 - When you open the door, an item may fall out and cause personal injury or material damage.
 - Do not spray volatile material such as insecticide onto the surface of the appliance.
 - As well as being harmful to humans, it may also result in an electric shock, fire, or problems with the product.
 - Never put fingers or any objects into the water dispenser outlet, ice chute, or ice maker bucket.
 - It may cause a personal injury or material damage.
 - Do not use or place any substances sensitive to temperature such as flammable sprays, flammable objects, dry ice, medicine, or chemicals near or inside the refrigerator.
 - Do not use a hair dryer to dry the inside of the refrigerator. Do not place a lighted candle in the refrigerator to remove bad odors.
 - This may result in an electric shock or fire.
 - Fill the water tank and ice cube trays with potable water only (tap water, mineral water, or purified water).
 - Do not fill the tank with tea, juice, or a sports drink. They can damage the refrigerator.
 - Do not stand on top of the appliance or place objects (such as laundry, lighted candles, lighted cigarettes, dishes, chemicals, metal objects, etc.) on the appliance. This may result in an electric shock, fire, problems with the product, or injury. Do not put a container filled with water on the appliance.
 - If spilled, there is a risk of fire or electric shock.
 - Never stare directly at the UV LED lamp for long periods of time.
 - This may result in eye strain due to the ultraviolet rays.
 - Do not put a fridge shelf into the refrigerator upside down. The shelf stopper will not work.
 - The glass shelf could fall and cause personal injury.
 - Keep fingers out of “pinch point” areas. Clearances between the doors and cabinet are necessarily small. Be careful when you open the doors if children are in the area.
 - If a gas leak is detected, avoid any naked flames or potential sources of ignition, and air the room in which the appliance is standing for several minutes.
 - Do not touch the appliance or power cord.
 - Do not use a ventilating fan.
 - A spark may result in an explosion or fire.
 - Use only the LED Lamps provided by the manufacturer or its service agents.
 - Bottles should be stored tightly together so that they do not fall over or out.
 - This product is intended only for the storage of food in a domestic environment.

Safety information

- Never put fingers or any objects into the water dispenser outlet, ice chute, or ice maker bucket.
 - This can cause a personal injury or material damage.
- Do not attempt to repair, disassemble, or modify the refrigerator yourself.
 - Unauthorized modifications can cause safety problems. To reverse an unauthorized modification, we will charge the full cost of parts and labor.
- Do not use any fuse (such as cooper, steel wire, etc.) other than a standard fuse.
- If your refrigerator needs to be repaired or reinstalled, contact your nearest Samsung service center.
 - Failing to do so may result in an electric shock, fire, problems with the product, or injury.
- If the interior or exterior LED lamp has gone out, contact your nearest Samsung service center.
- If the refrigerator emits a burning smell or smoke, unplug the refrigerator immediately and contact a Samsung service center.
 - Failing to do so may result in an electric or fire hazards.
- Pull the power plug out of the socket before changing the interior lamps of the refrigerator.
 - Otherwise, there is a risk of electric shock.
- If you experience difficulty changing a non-LED light, contact a Samsung service center.
- If the product is equipped with LED lamps, do not disassemble the Lamp Covers and LED lamps yourself.
 - Contact a Samsung service center.
- Plug the power plug into the wall socket firmly.
- Do not use a damaged power plug, damaged power cord, or loose wall socket.
 - This may result in an electric shock or fire.

Usage cautions

CAUTION

- Do not re-freeze frozen foods that have thawed completely.
- Use only the ice maker provided with the refrigerator.
- To get the best performance from the product:
 - Do not place food too close to the vents at the rear of the refrigerator as this can obstruct free air circulation in the refrigerator compartment.
 - Wrap food up properly or place it in airtight containers before putting it into the refrigerator.
 - Please observe maximum storage times and expiration dates of frozen goods.
- Do not put glass containers or bottles or carbonated beverages into the freezer.
 - The container may freeze and break, and this may result in injury.
- Service Warranty and Modification.
 - Any changes or modifications performed by a 3rd party on this finished appliance are not covered under Samsung warranty service, nor is Samsung responsible for safety issues that result from 3rd party modifications.
- Do not block the air vents inside the refrigerator.
 - If the air vents are blocked, especially with a plastic bag, the refrigerator can be over cooled. If a cooling period lasts too long, the water filter may break and cause water leakage.
- If the refrigerator is disconnected from the power supply, you should wait for at least five minutes before plugging it back in.
- If large amounts of water enter the refrigerator, pull out the power plug and contact a Samsung service center.
- Do not strike or apply excessive force to any glass surface.
 - Broken glass may result in a personal injury and/or property damage.
- Fill the water tank and ice cube trays with potable water only (tap water, mineral water, or purified water).
 - Do not fill the tank with tea, juice, or a sports drink. They can damage the refrigerator.
- If the refrigerator is flooded, shut off the power to the refrigerator and contact your nearest Samsung service center.
 - There is a risk of electric shock or fire.
- Do not keep vegetable oil in your refrigerator's door bins. The oil can solidify, making it foul-tasting and difficult to use. In addition, the open container can leak and the leaked oil can cause the door bin to crack. After opening an oil container, it is best to keep the container in a cool and shaded place such as a cupboard or pantry.
 - Examples of vegetable oil: olive oil, corn oil, grape-seed oil, etc.

Safety information

Cleaning cautions

CAUTION

- Do not spray water directly on the inside or outside of the refrigerator.
 - There is a risk of fire or electric shock.
- Do not use a hair dryer to dry the inside of the refrigerator.
- Do not place a lighted candle in the refrigerator to remove bad odors.
 - This may result in an electric shock or fire.
- Do not spray cleaning products directly on the display.
 - Printed letters on the display may come off.
- If any foreign substance such as water has entered the appliance, unplug the power plug and contact your nearest Samsung service center.
 - Failing to do so may result in an electric shock or fire.
- Use a clean, dry cloth to remove any foreign matter or dust from the power plug blades. Do not use a wet or damp cloth when cleaning the plug.
 - Otherwise, there is a risk of fire or electric shock.
- Do not clean the appliance by spraying water directly onto it.
- Do not use benzene, thinner, or Clorox (bleach) to clean the refrigerator.
 - They may damage the surface of the appliance and may cause a fire.
- Never put fingers or any objects into the dispenser outlet.
 - This can cause a personal injury or material damage.
- Before cleaning or performing maintenance, unplug the appliance from the wall socket.
 - Failing to do so may result in an electric shock or fire.
- Use a clean sponge or soft cloth and a mild detergent in warm water to clean the refrigerator.
- Do not use abrasive or harsh cleansers such as window sprays, scouring cleansers, flammable fluids, muriatic acid, cleaning waxes, concentrated detergents, bleaches, or cleansers containing petroleum products on exterior surfaces (doors and cabinet), plastic parts, door and interior liners, and gaskets.
 - These can scratch or damage the material.
- Do not clean glass shelves or covers with warm water when they are cold. Glass shelves and covers may break if exposed to sudden temperature changes or impacts such as bumping or dropping.

Critical disposal warnings

WARNING

- Children trapped inside a refrigerator can hurt themselves or suffocate to death.
- Please dispose of the packaging material from this product in an environmentally friendly manner.
- Ensure that none of the pipes on the back of the refrigerator are damaged prior to disposal.
- This product contains R-600a, a flammable gas, which is used as the refrigerant. Contact your local authorities regarding safe disposal of this product.
- When disposing of this refrigerator, remove the door/door seals and door latch so that small children or animals cannot become trapped inside. Children should be supervised to ensure that they do not play with the appliance.
 - If trapped inside, the child could be injured or suffocate to death.
- Cyclopentane is used in the insulation. The gases in the insulation material require a special disposal procedure. Please contact your local authorities in regard to the environmentally safe disposal of this product.
- Keep all packaging materials well out of the reach of children, as packaging materials can be dangerous to children.
 - If a child places a bag over his or her head, the child could suffocate.

Installation

Follow these instructions carefully to ensure a proper installation of this refrigerator and to prevent accidents before using it.

WARNING

- Use the refrigerator only for its intended purpose as described in this manual.
- Any servicing must be performed by a qualified technician.
- Dispose of the product packaging material in compliance with the local regulations.
- To prevent electric shock, unplug the power plug before servicing or replacing parts.

Refrigerator at a glance

The actual refrigerator and provided component parts of your refrigerator may differ from the illustrations in this manual, depending on the model and the country.

Type A

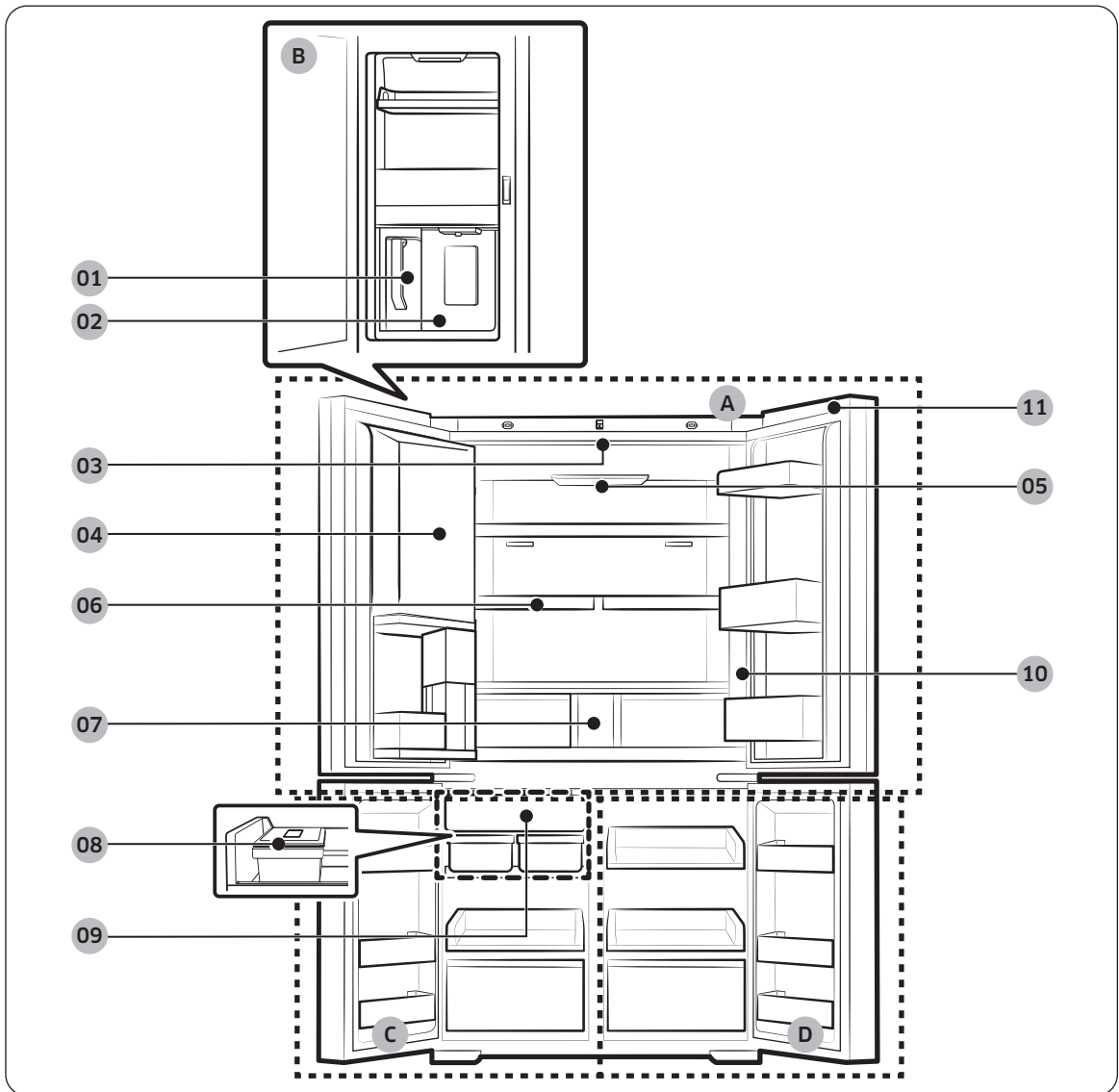

Installation

Type B

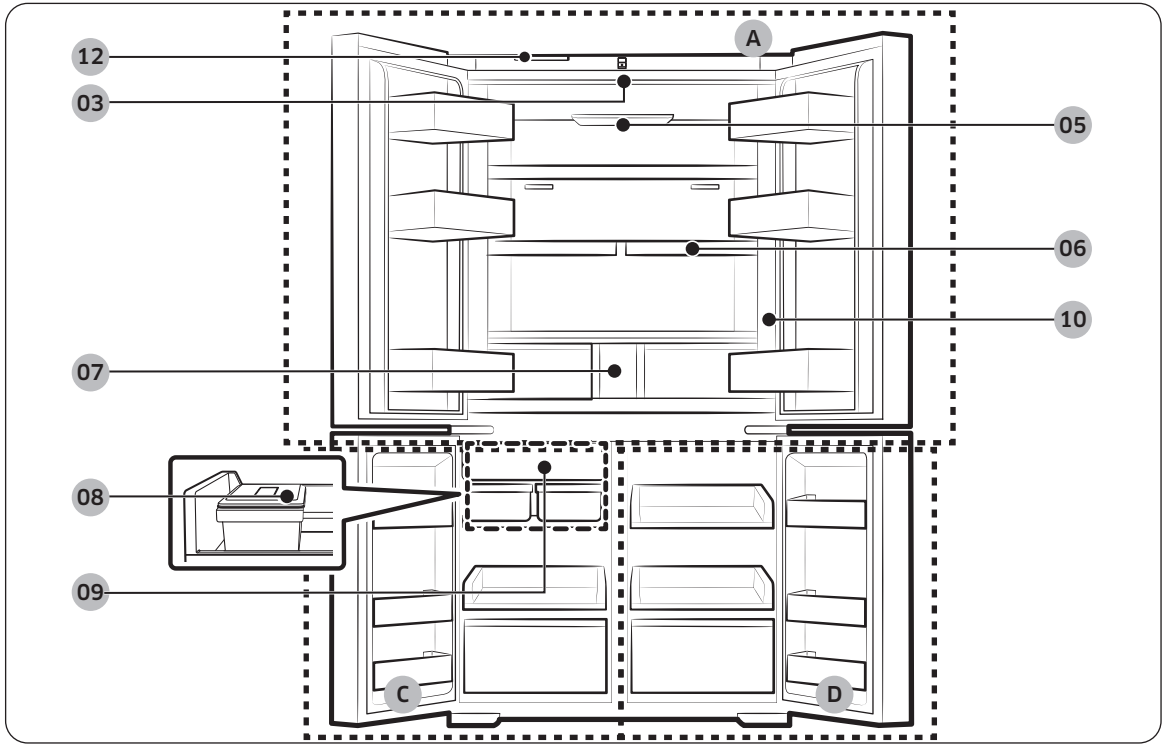

01 AutoFill Pitcher **

03 Camera *

05 UV Deodorizing Filter *

07 Water filter **

09 Auto Ice Maker **

11 Switch Cover *

* Applicable models only

02 Water dispenser **

04 Beverage Zone *

06 Quick Space shelf

08 Tray Ice Maker *

10 Main panel *

12 Mesh filter *

** Dispenser models only

A. Fridge

B. Beverage Center **

C. Freezer

D. FlexZone

NOTE

- For energy efficiency, keep all shelves, drawers, and baskets in their original positions.
- When closing the door, make sure the vertical hinged section is in the correct position to avoid scratching the other door.
- If the vertical hinged section is reversed, put it back into the correct position, and then close the door.
- Moisture may form at times on the vertical hinged section.
- If you close a door forcefully, the other door may open.
- If the internal or external LED lamp is out of order, contact a local Samsung service center.

Door bins

Your refrigerator ships with door bins of different types and sizes. If the door bins for your refrigerator were packaged separately, use the figure below to help you position the bins properly.

NOTE

The actual refrigerator and provided component parts of your refrigerator may differ from the illustrations in this manual, depending on the model and the country.

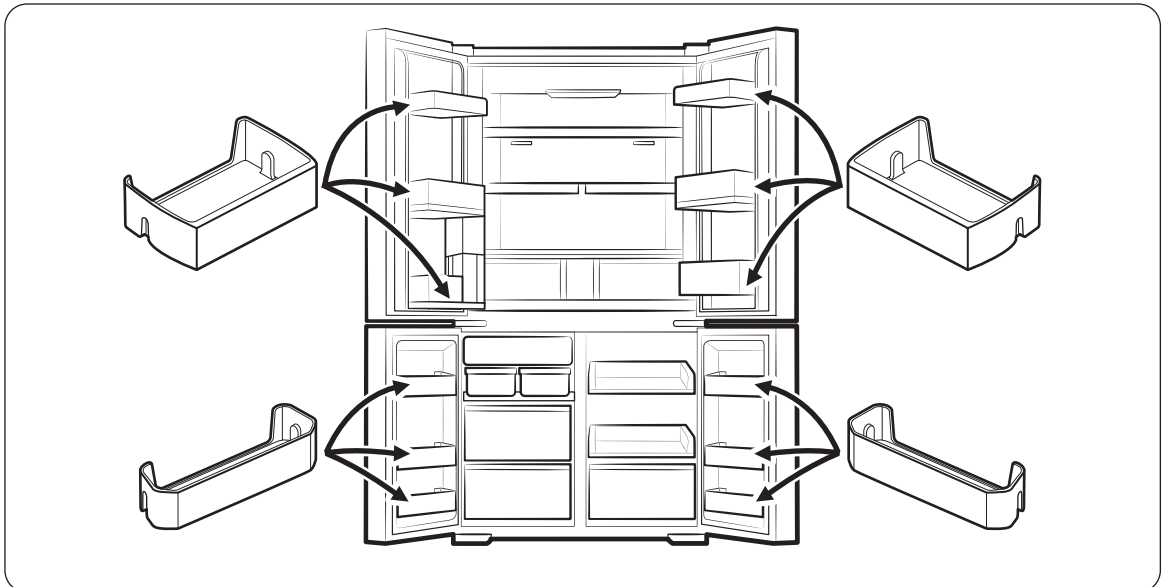

Installation

Step-by-step installation

STEP 1 Select a site

The site must:

- Have a solid level surface without carpeting or flooring that may obstruct ventilation
- Be out of direct sunlight
- Have adequate room for opening and closing the door
- Be away from any heat source
- Provide room for maintenance and servicing
- Have a temperature range between 50 °F (10 °C) and 110 °F (43 °C)

Clearance

See the pictures and table below and on the next page for installation space requirements.

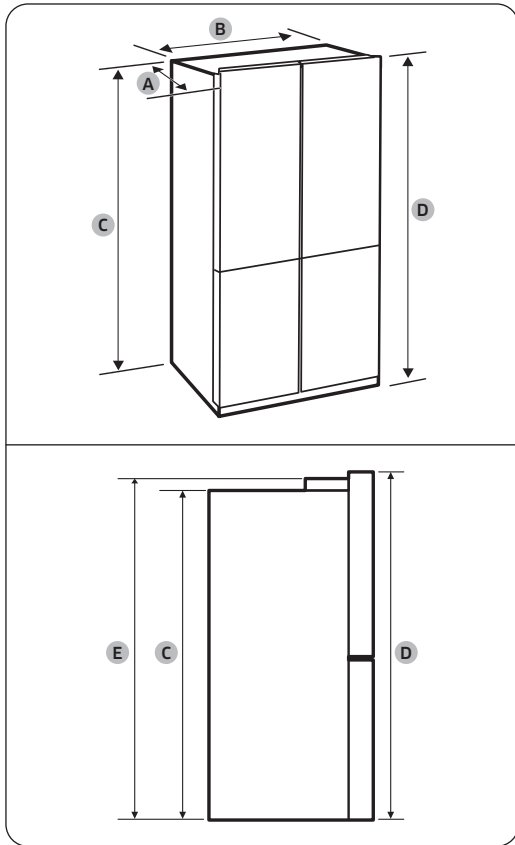

Model	RM**F23*
A	28 ³ / ₄ " (731 mm)
B	35 ⁷ / ₈ " (912 mm)
C	70 ³ / ₄ " (1797 mm)
D	73" (1853 mm)
E	72 ¹ / ₈ " (1833 mm)

Model	RM**F22* (Kitchen Fit)
A	26 ⁷ / ₈ " (683 mm)
B	35 ⁷ / ₈ " (912 mm)
C	70 ³ / ₄ " (1797 mm)
D	73" (1853 mm)
E	72 ¹ / ₈ " (1833 mm)

- A. Depth
- B. Width
- C. Height (without hinge)
- D. Overall Height
- E. Height (with hinge)

Installation

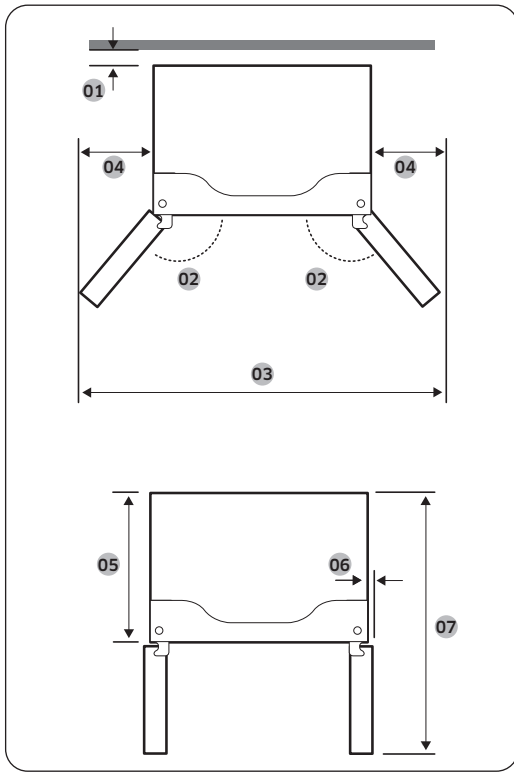

Model	RM**F23*	RM**F22* (Kitchen Fit)
01	more than 50 mm recommended	
02	125°	108°
03	59" (1498 mm)	45 1/2" (1157 mm)
04	11 3/4" (295 mm)	5" (125 mm)
05	24" (610 mm)	24" (610 mm)
06	2 1/4" (55 mm)	1/8" (4 mm)
07	43" (1093 mm)	43" (1093 mm)

NOTE

The measurements of your refrigerator may differ from those listed above, depending on the measuring method.

STEP 2 Spacing (applicable models only)

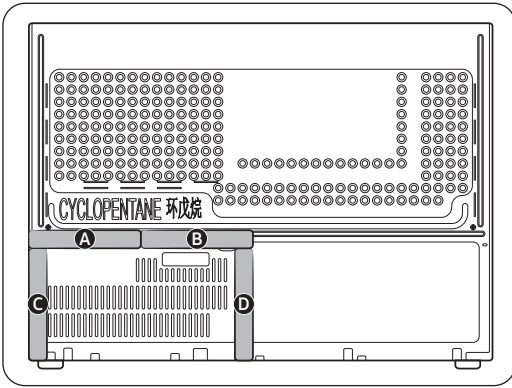

Attach the provided spacers around the vent holes on the compressor cover at the lower left corner of the refrigerator as shown in the figure for optimal energy efficiency.

- First, attach the **spacer (A)**, aligning it with the left end and the top of the protrusion on the compressor cover. Then attach the **spacers (B), (C), and (D)** in order, ensuring the ends are flush with each other.

STEP 3 Flooring

If the refrigerator cannot pass through the entrance due to its size, see **STEP 4 Door removal** for entrance.

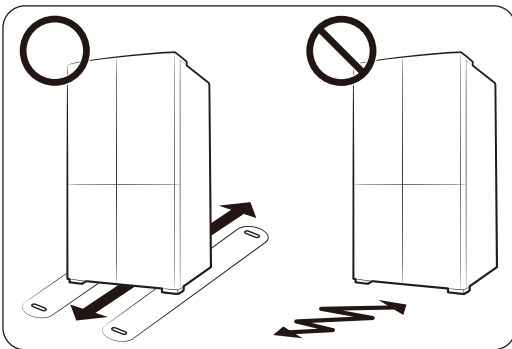

NOTE

To prevent floor damage, make sure the front leveling legs are in the upright position.

- The surface you install the refrigerator on must support a fully loaded refrigerator.
- To protect the floor, put a large piece of cardboard along the path to the refrigerator's final installation location.
- Once the refrigerator is in its final position, do not move it unless necessary to protect the floor. If you have to move the refrigerator, place thick paper or cloth such as old carpets along the path of movement.

Installation

STEP 4 Door removal for entrance

If the refrigerator cannot pass through the entrance to your home or kitchen due to its size, follow these instructions to remove and then re-install the refrigerator's doors. If you do not need to remove the doors, go to page 32 to continue the installation procedure.

WARNING

Unplug the power cord of the refrigerator before removing the doors.

Tools required (not provided)

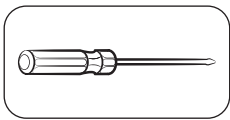

Phillips screwdriver

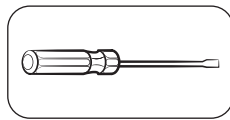

Flat-head screwdriver

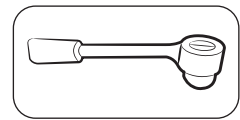

Socket wrench $\frac{3}{8}$ " (10 mm)

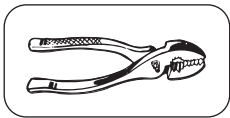

Pliers

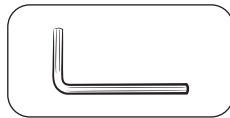

Allen wrench $\frac{1}{4}$ " (5 mm)

Detach the fridge doors

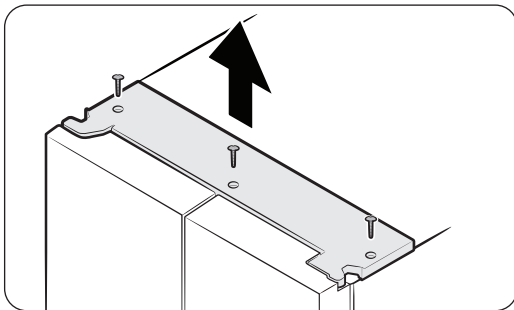

1. With the doors closed, use a Phillips screwdriver to remove the screws (x3) from the top cover. Pull up and remove the top cover with the connectors.

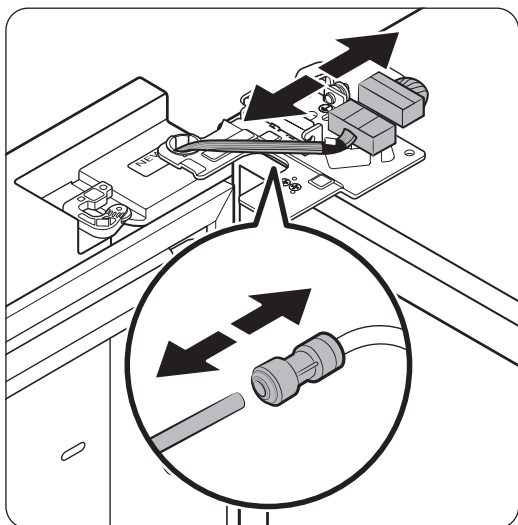

2. Disconnect the two wire connectors on the left door. The position of the connectors differs with the model.

⚠ CAUTION

- Do not remove both doors simultaneously. Make sure to remove one door at a time. Otherwise, any of the doors may fall and cause physical injury.
 - Make sure the refrigerator is off before disconnecting the connectors.
3. Disconnect the water tube from the coupler on the left door as shown.
 - This step does not apply to the models without the AutoFill Pitcher and the water dispenser.
 4. Gently draw up the clamp in several steps. To prevent finger injuries, do not apply a sudden force to the clamp.

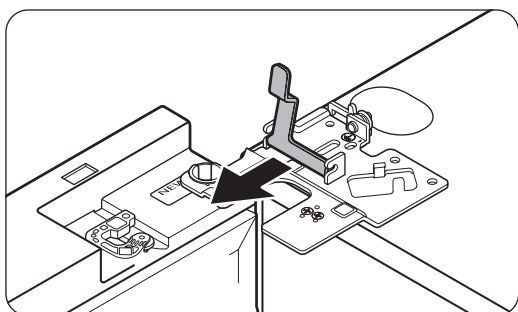
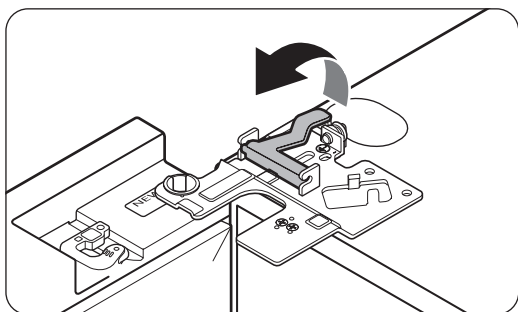

5. Pull up the clamp to remove.

Installation

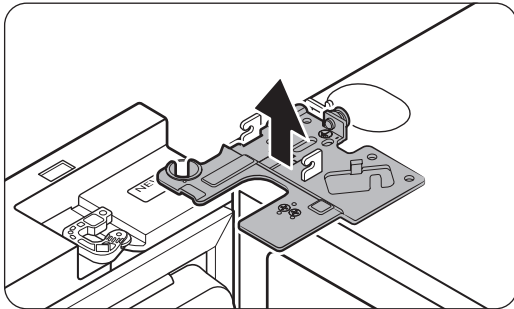

6. Open the door 90 degrees. While holding the door, pull up and remove the top hinge. Be careful not to damage the connector wires when you remove the hinge.

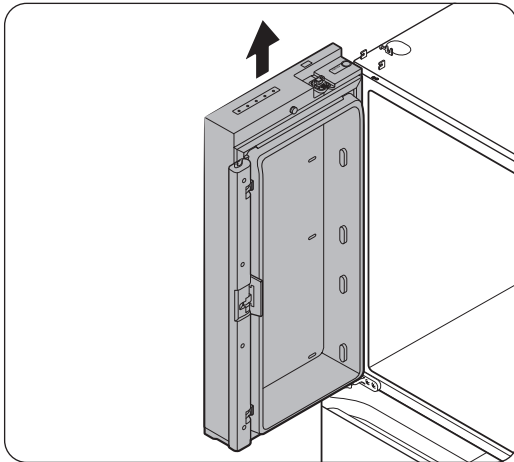

7. Gently pull up the door vertically to remove. Do not apply excessive force to the door. The door may fall, causing physical injury.
8. Lay the door down on a flat surface.
9. Repeat steps 1-8 for the other door, except for step 3. There is no water tube on the right side door.
 - Step 2 does not apply to the models without the Showcase door.

Detach the freezer doors

CAUTION

- Be sure to remove the fridge doors before removing the freezer doors.
- Use caution when disconnecting the bottom connectors.

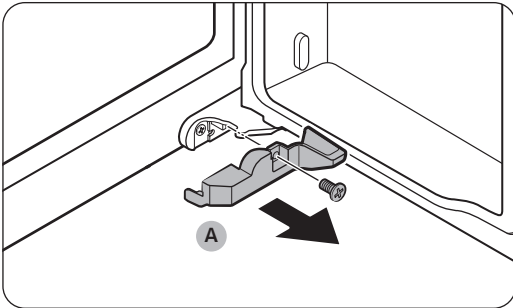

1. Open the freezer door.
2. Use a Phillips screwdriver to remove the screw holding the **cover (A)**.
 - This step only applies to the right side freezer door (FlexZone door).

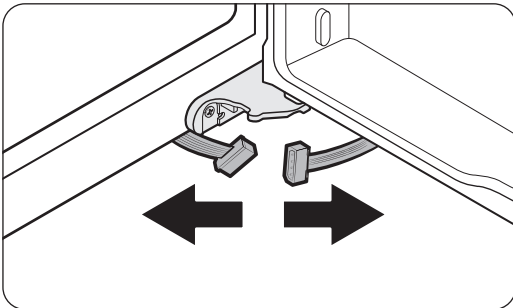

3. Disconnect the wire connectors.
 - This step only applies to the right side freezer door (FlexZone door).

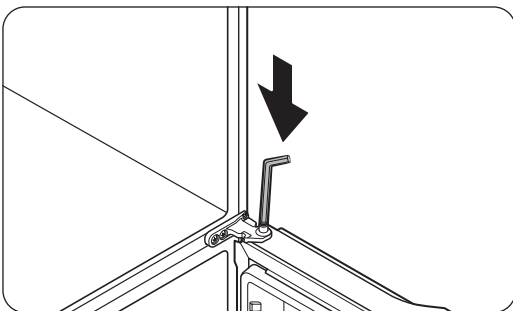

4. Locate the hinge shaft. While holding the door with one hand, use a flat-head screwdriver or Allen wrench to press the shaft down. Make sure to hold the door to prevent the door from falling.

Installation

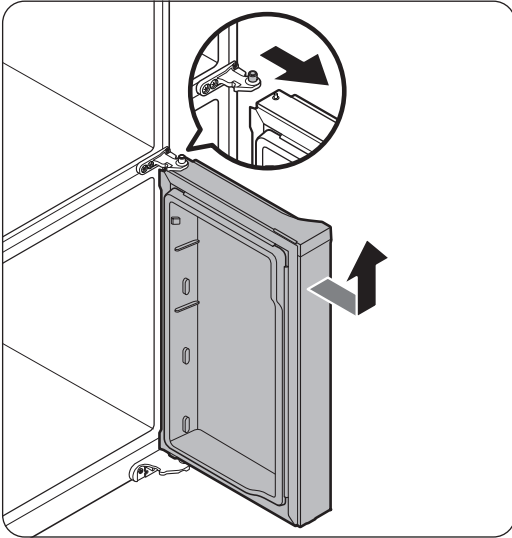

5. To prevent contact with the middle hinge, slightly tilt the door to the front, and then lift it up to remove.
6. Repeat steps 1-5 for the other door, except for steps 2 and 3.

To reattach the freezer doors

! CAUTION

- The freezer doors must be re-attached before the fridge doors.
- Be careful not to damage or step on the wires during this process.

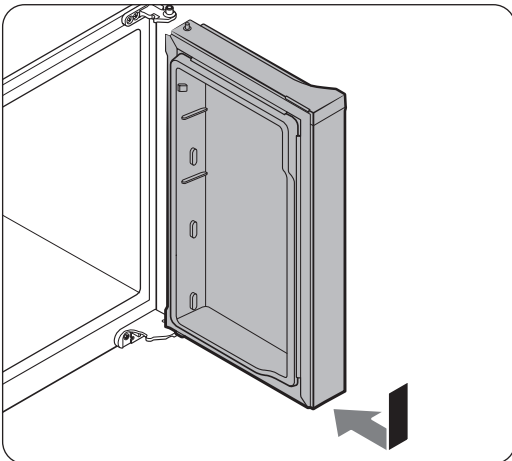

1. Insert the freezer door into the bottom hinge while pushing the freezer door in the direction of the arrow.

! CAUTION

- Be careful not to damage or step on the wires during this process.

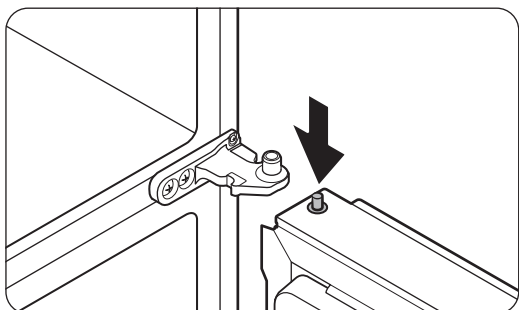

2. While pressing the hinge shaft down, position the door so that the hinge shaft is below the shaft hole in the middle hinge. Release the hinge shaft so that it enters the shaft hole.

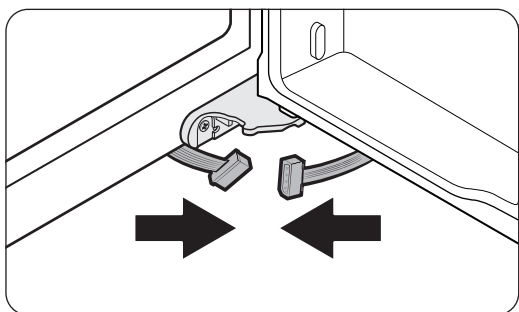

3. With the door open, connect the bottom connectors in the direction of the arrows.
 - This step only applies to the right side freezer door (FlexZone door).

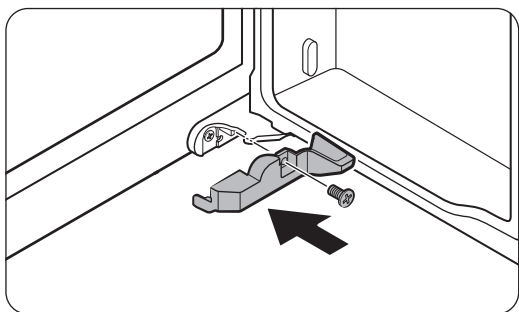

4. Attach the cover using a Phillips screwdriver. Be careful not to damage or step on the connectors.
 - This step only applies to the right side freezer door (FlexZone door).
5. Repeat steps 1-5 for the other door, except for steps 3 and 4.

Installation

To reattach the fridge doors

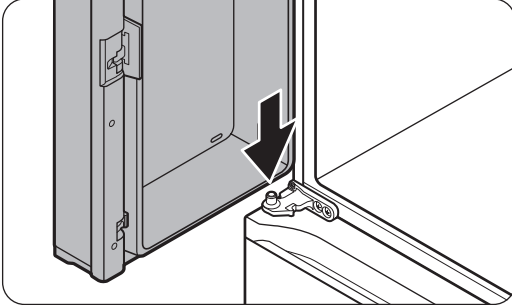

1. While holding the door open by more than 90 degrees, insert the shaft on the middle hinge into the hole on the bottom of the door.

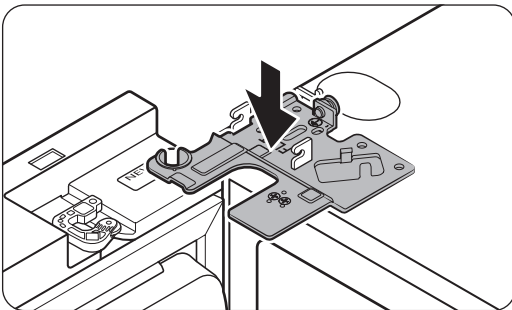

2. Put the top hinge into position on the top of the refrigerator, and then insert the hinge shaft into the top hole of the door. Make sure the wires from the door pass through the hole in the hinge shaft.

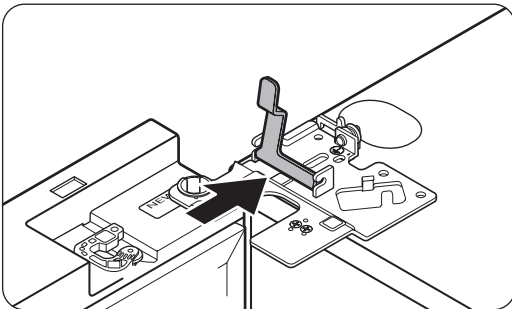

3. Insert the clamp in the direction of the arrow.

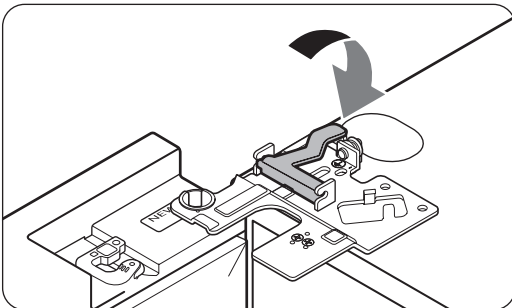

4. Push back the clamp as shown.

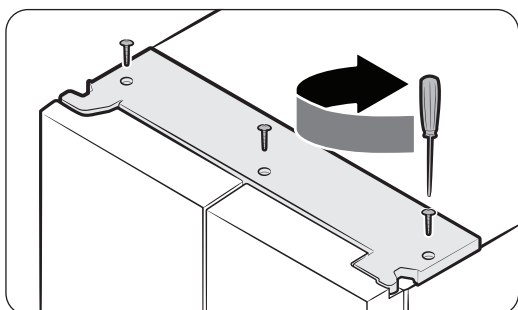
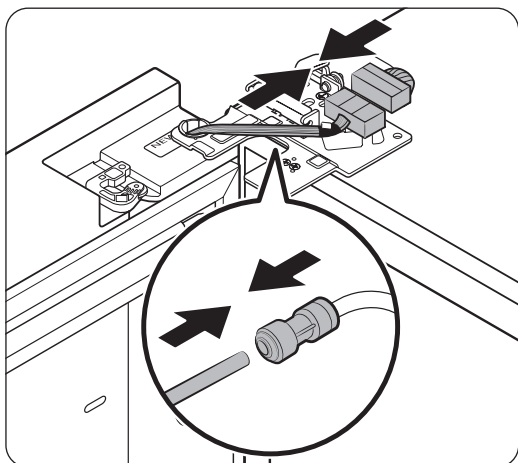

5. Connect the wire connectors.

⚠ CAUTION

- Make sure the wire connectors are connected properly. Otherwise, the display will not operate.

6. Connect the water tube.

- This step does not apply to the models without the AutoFill Pitcher and the water dispenser.

⚠ CAUTION

- To prevent water leaks, make sure the red clips tighten the coupler properly.
- Keep the clips out of children's reach.

7. Repeat steps 1-5 for the other door.

- Step 5 does not apply to the models without the Showcase door.

8. Attach the top cover with the front side first, and then press down on its back to get it into position. Then, tighten the screws (x3).

Installation

STEP 5 Leveling the refrigerator

Adjusting the front height

CAUTION

- When installed, the refrigerator must be leveled on a flat, solid floor. Not leveling the refrigerator can cause damage to the refrigerator or physical injury.
- Leveling must be performed with the refrigerator empty. Make sure no food items are inside the refrigerator.
- For safety reasons, adjust the front a little higher than the rear.

Level the refrigerator using the special screws (leveler) on the front legs. Use a flat-head screwdriver to turn the leveler.

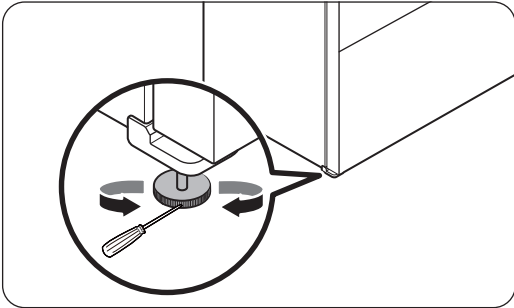

Insert a flat-head screwdriver into the leveler of the front left or right leg. Turn the leveler clockwise to raise or turn it counterclockwise to lower.

Adjusting the rear side height (applicable models only)

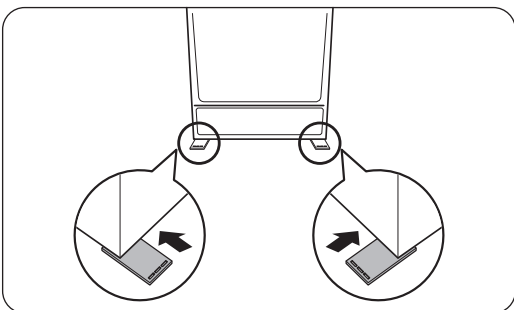

If you need to raise the rear side of the refrigerator to level it, you can use the provided level adjustment pad(s). Follow these instructions to raise the rear side of the refrigerator.

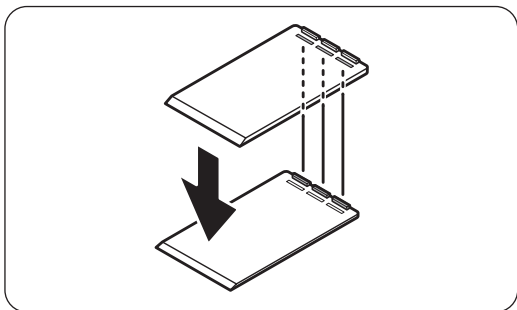
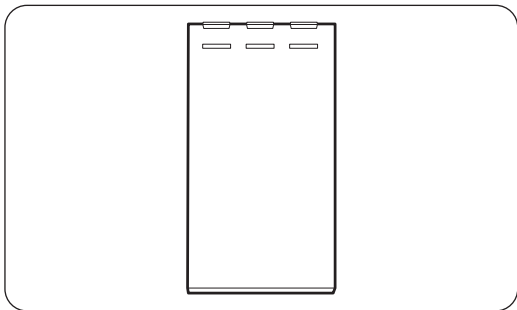
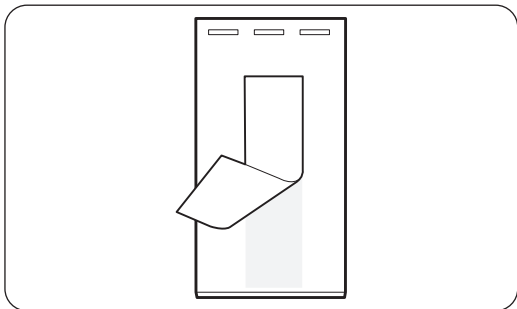

1. Choose the position on the floor where you need to attach the level adjustment pad.
2. Peel the double-sided tape on the bottom of the level adjustment pad.

3. Attach the level adjustment pad to the floor.

4. If you need to further raise the rear height, attach another adjustment pad on top of the first level adjustment pad.

 **NOTE**

- You may skip this step if you can level the refrigerator using a single attachment pad.
- Make sure the ribs on the first adjustment pad are inserted into the grooves of the second level adjustment pad.

Installation

STEP 6 Adjust the door height

Adjusting the height with the height lever (applicable models only)

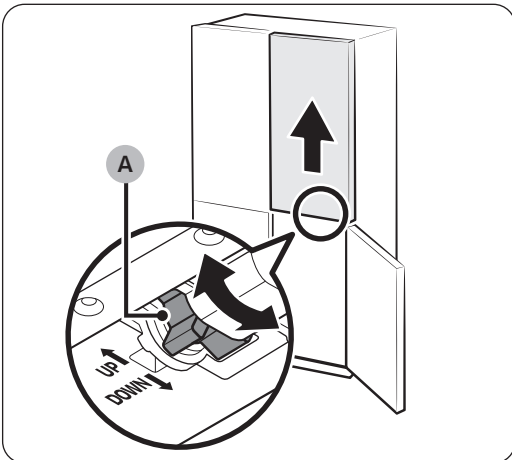
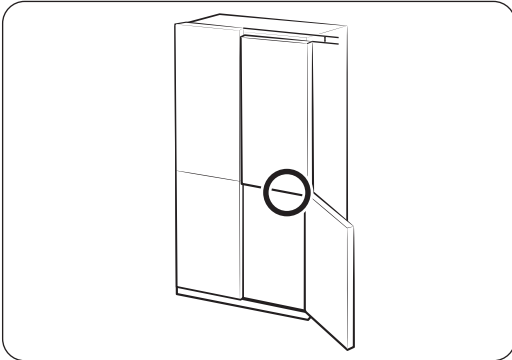

- Before aligning the door height, make sure the refrigerator is leveled properly. Use the leveling legs for this purpose.
- You can use the height lever at the bottom of the right-side door of the fridge. Open the right-side door of the freezer with both fridge doors closed and use the lever to adjust the door height.
- Turn the **height lever (A)** until the two doors are aligned at the top. Turn the lever toward **UP** (as marked) to raise the right-side door and turn it toward **DOWN** (as marked) to lower the door.
- Lift the fridge door slightly to make alignment easier. The maximum adjustable height is 3 mm.
 - The lever will not turn past the maximum limit. It may make a noise if it is turned too far.
 - Excessive height may interfere with the upper hinge cover of the fridge door.
- If you align the door height with the door bins empty and then store items in the bins, the heights may differ again. If this happens, follow the steps above to realign the doors.

Adjusting the height with the snap rings

For the models with the height lever on the right-side door of the fridge, use the snaps only if you cannot align the doors with the height lever.

You may find the provided snap rings inside the fridge drawer.

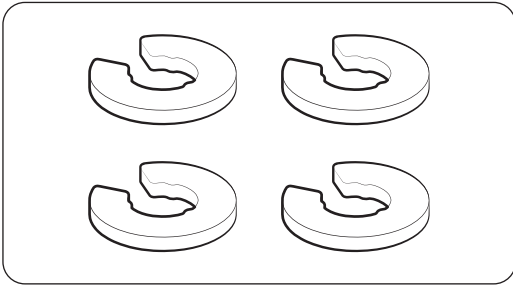

NOTE

The height of a door can be adjusted using the provided snap rings, which come in 4 different sizes (1 mm, 1.5 mm, 2 mm, and 2.5 mm).

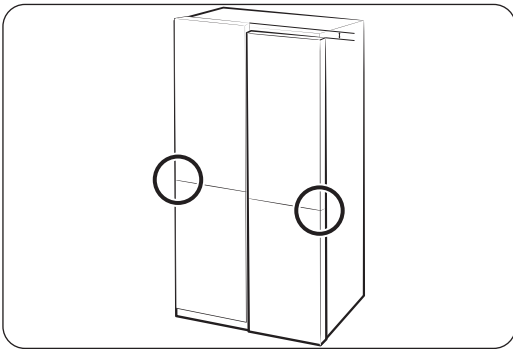

1. Check the height difference between the doors, and then lift up and hold the door with the lower height.

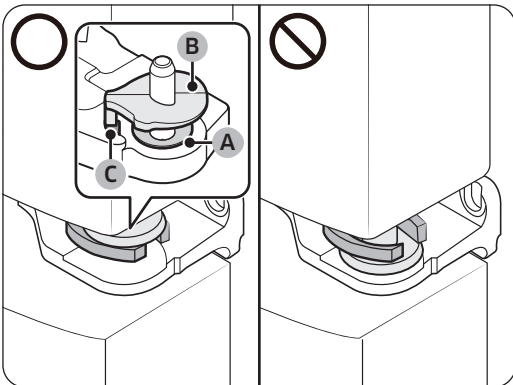

2. Insert a suitable-sized snap ring (A) between the door grommet (B) and the hinge as shown.

NOTE

Ensure the snap ring (A) is inserted beneath the door grommet (B).
Ensure the shaft of the door grommet (B) is inserted into the hole (C) in the hinge.

CAUTION

- Insert only one snap ring. If you insert two or more snap rings, the rings may slip out or make a rubbing noise.
- Keep the snap rings out of children's reach and keep them for future use.
- Do not raise the door too much. The door can contact and damage the top cover.

Installation

- If the ring is placed above the grommet, it may cause noise when the refrigerator door is opened or closed.

Adjusting the freezer door height (applicable models only)

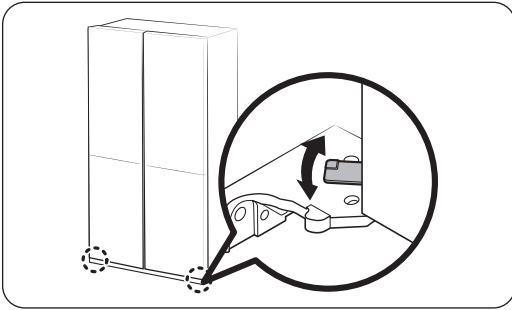

- Before aligning the door height, make sure the refrigerator is leveled properly. Use the leveling legs for this purpose.
- You can adjust the height of both freezer doors using the lever located at the bottom hinge.
- Open the door, lift it a little, and then turn the lever left or right to adjust the height.

Adjusting the gap between the fridge doors and the main body of the refrigerator (applicable models only)

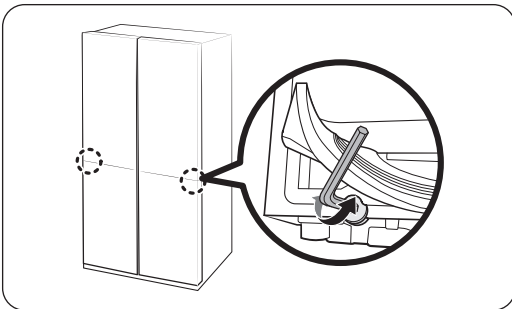

- You can adjust the gap between both fridge doors and the main body of the refrigerator using the adjustment bolt located at the bottom of the fridge compartment.
- Lift the door gasket and located the adjustment bolt underneath the gasket. Use the 4 mm Allen wrench to adjust the gap.

⚠ CAUTION

Make sure you firmly attach the gasket. Otherwise, cold air from the refrigerator may leak.

Adjusting the gap between the doors and the main body of the refrigerator (applicable models only)

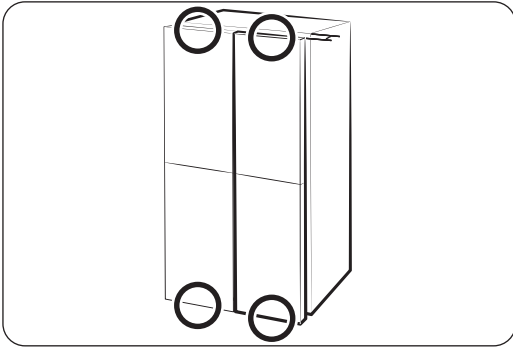

You can adjust the gap between all four doors and the main body of the refrigerator using the adjustment dial. (Refer to the figure for the location of the adjustment dial.)

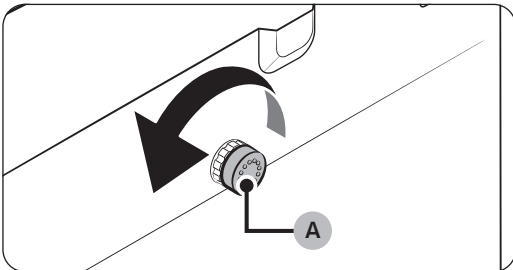

1. Open the door that is closer to the main body than the others. Then, turn the **adjustment dial (A)** counterclockwise until the gap becomes even with the others.

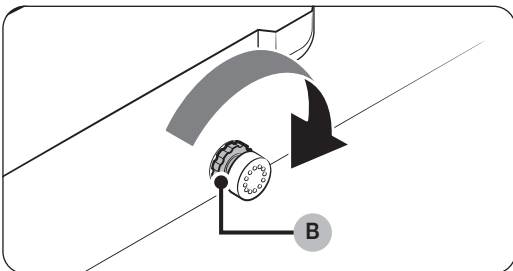

2. After adjusting the gap, turn the **locking nut (B)** to lock the **adjustment dial**.

 **NOTE**

Each time you turn the **adjustment dial**, the gap is adjusted by 1 mm. However, the door may not close properly if you adjust the door by more than 1.5 mm.

Installation

STEP 7 Connect the water line

You must connect a water line from the main water supply to your refrigerator to use the water dispenser or the auto ice maker. A water filter is provided for removing unwanted particles from the main water supply, but it does not sterilize or eliminate microorganisms in the water, and you may need to purchase a water purifying system for that purpose.

Water pressure

The water pressure supplied to the refrigerator must meet the following requirements:

Minimum	Maximum
30 psi (206 kPa)	125 psi (861 kPa)

If the refrigerator is installed in an area where minimum water pressure cannot be met, you can install a booster pump to compensate for the low water pressure.

Connect the water supply line to the main water supply

NOTE

- Only connect the water line to potable water.
- Water line installation kits are available at extra cost from your retailer. We recommend using a water line installation kit that contains copper tubing and a 1/4" (6 mm) compression nut.

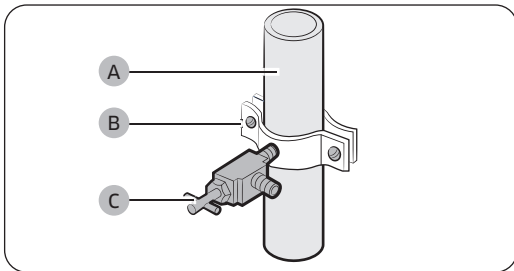

1. Shut off the main water supply.
2. Insert the **pipe clamp (B)** and the **shutoff valve (C)** into the **cold water line (A)**.

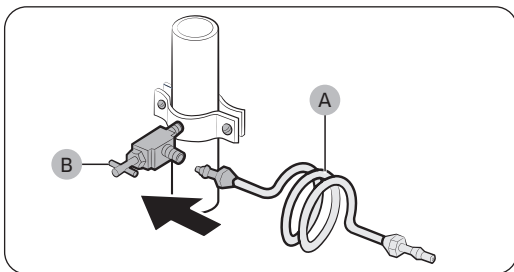

3. Connect the **water line installation kit (A)** to the **shutoff valve (B)**.

Connect the water supply line to the refrigerator

There are several items you must purchase to complete this connection. You may find these items sold as a kit at your local hardware store.

Copper Tubing	<ul style="list-style-type: none"> • 1/4" copper tubing • 1/4" compression nut (1 pc) • Ferrule (2 pcs)
Plastic Tubing	<ul style="list-style-type: none"> • 1/4" plastic tubing with molded end (Bulb) • 1/4" compression nut (1 pc)

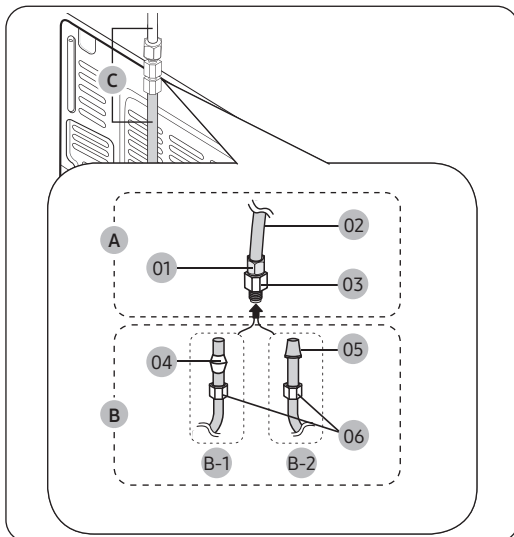

A	The water line from the refrigerator	
	01	Compression nut (1/4") (Assembled)
	02	Plastic tubing (Assembled)
	03	Compression fitting (Assembled)
B	The water line from the main water supply	
	NOTE	
	You can choose the water line from the main water supply to be copper tubing (B-1) or plastic tubing (B-2).	
	B-1	Copper tubing (Not supplied)
	B-2	Plastic tubing (Not supplied)
	04	Ferrule (Not supplied)
	05	Molded end (Bulb)
	06	Compression nut (1/4") (Not supplied)
C	Water line	
	NOTE	
	Assemble water lines must be kept straight.	

Installation

1. Connect the water line from the main water supply (B) to the assembled compression fitting (03).
 - If you are using copper tubing (B-1), slip the compression nut (06) (not supplied) and ferrule (04) (not supplied) on the copper tubing (B-1) (not supplied) as shown in the figure.
 - If you are using plastic tubing (B-2), insert the molded end (Bulb) (05) of the plastic tubing (B-2) (not supplied) into the compression fitting (03).

CAUTION

- If you use plastic tubing (B-2), do not use it without the molded end (Bulb) (05).
 - Leaving the water line disconnected may cause the water valve to produce a buzzing sound over time. If this is the case, make sure that the ice making function is turned off and do not attempt to use the water dispenser.
2. Tighten the compression nut (06) onto the compression fitting (03). Do not over-tighten the compression nut (06).
 3. Turn the water on and check for any leakage. If you find water drops or leakage in the connection areas, turn off the main water supply. Check the connections and, if necessary, tighten.
 - Check if the water dispenser works properly. Press the water dispenser lever until the water runs from the water outlet.
 4. Flush 3 gallons of water through the filter before drinking or using the water from the refrigerator. (Flush approximately 5 to 6 minutes.) To flush, press a large glass or cup against the water dispenser lever. Fill the glass, empty it, and then repeat.
 5. After you turn on the refrigerator, let the ice maker make ice for 1 to 2 days. Over that period of time, throw out the first 1 or 2 buckets of ice the ice maker makes to ensure all impurities have been removed from the water line.

CAUTION

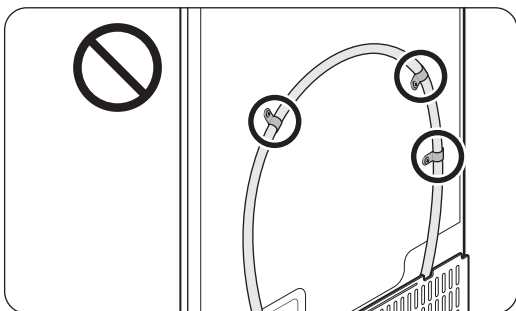

- Do not mount the water filter or water line on any part of the refrigerator. This may damage the refrigerator.

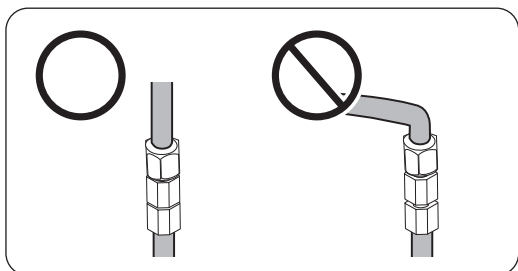

- If you have to relocate the refrigerator after connecting the water line, make sure the joined section of the water line is straight.

NOTE

- If you have to repair or disassemble the water line, cut off $\frac{1}{4}$ " of the plastic tubing to make sure you get a snug, leak-free connection.
- You can test the water line quickly using a paper cup. Under normal conditions, the water dispenser can fill a $5\frac{3}{4}$ oz. (170 cc) cup in about 10 seconds.

STEP 8 Initial settings

By completing the following steps, the refrigerator should be fully functioning.

1. Plug the power cord into the wall socket to turn the refrigerator on.
2. Open the door, and check if the interior light lights up.
3. Set the temperature to the coldest setting, and wait for about an hour. Then, the freezer will be slightly chilled, and the motor should be running smoothly.
4. Wait until the refrigerator reaches the set temperature. Now the refrigerator is ready for use.

STEP 9 Final check

When installation is complete, confirm that:

- The refrigerator is plugged into an electrical outlet and grounded properly.
- The refrigerator is installed on a flat level surface with a reasonable clearance from walls and cabinets.
- The refrigerator is leveled and is sitting firmly on the floor.
- The door opens and closes freely, and the interior light turns on automatically when you open the door.

Operations

Main panel

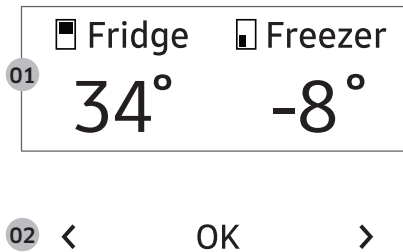

01 Display	Displays the menu, settings, and other information.
02 Buttons	<ul style="list-style-type: none">• When the display is off, tap any button to wake up the display.• Tap < or > to navigate left and right.• Tap OK to confirm your selection.• Tap and hold OK to enter the AP mode. (For more information, see the “SmartThings > Getting started” section on page 49.)

NOTE

- If the door is left open for 5 minutes, the internal light will blink for 5 minutes and turn off. It is to alert deaf and hard of hearing users that a door is open. Note that this function is normal.
- When you change the temperature on the panel, the panel displays the actual temperature inside the refrigerator until the temperature matches the temperature you set. Then, the panel displays the new set temperature. Note that it will take time for the refrigerator to reach the new temperature. It is normal. During this time, you need not set the temperature again.



Using the main panel

1. Tap any button (<, **OK**, or >) to wake up the display.
2. Tap < or > to select the desired menu, and then tap **OK** to confirm.
3. Tap < or > to select the desired setting, and then tap **OK** to confirm.
 - For more information on available settings, see the **Menu descriptions** section.

Menu descriptions

<p>Fridge</p>	<ul style="list-style-type: none"> You can set the fridge temperature from 34 to 44 °F (1 to 7 °C) or set the Power Cool function. Power Cool speeds up the cooling process at maximum fan speed. The fridge keeps running at full speed for two and a half hours and then returns to the previous temperature.
<p>Freezer</p>	<ul style="list-style-type: none"> You can set the freezer temperature from -8 to 5 °F (-23 to -15 °C) or set the Power Freeze function. Power Freeze speeds up the freezing process at maximum fan speed. The freezer keeps running at full speed for 50 hours and then returns to the previous temperature. To freeze large amounts of food, activate Power Freeze for at least 20 hours before putting food in the freezer.
<p>FlexZone</p>	<ul style="list-style-type: none"> You can set the FlexZone mode from one of the following modes. <ul style="list-style-type: none"> Freeze: The temperature is set to the same temperature as the freezer. Soft Freeze: The temperature is set to 23 °F (-5 °C). Meat/Fish: The temperature is set to 30 °F (-1 °C). Fruit/Veggies: The temperature is set to 36 °F (2 °C). Beverage: The temperature is set to 41 °F (5 °C). <p>⚠ CAUTION</p> <ul style="list-style-type: none"> Select the FlexZone mode according to the type of food you store in there. Do not store meat or food in the FlexZone with the Fruit/Veggies or Wine mode. Meat or food may spoil. Do not store glass bottles in the FlexZone in Freeze or Soft Freeze mode. They may break and cause physical injury.

Operations

Beverage Zone *	<ul style="list-style-type: none"> • You can set the Beverage Zone mode from one of the following modes. <ul style="list-style-type: none"> - Beverage: The temperature is set to the same temperature as the fridge. - Wine/Dessert: The temperature is set to 4 to 5 °C higher than the fridge, which is ideal for keeping desserts, wines, butter, and jam. <p> CAUTION</p> <ul style="list-style-type: none"> • Storing food in Wine/Dessert mode can result in a shorter storage time period because the temperature is higher than in the fridge. Therefore, if the food is not going to be consumed within a few days or is sensitive to temperature changes, keep it in the fridge. • Store any opened or leftover desserts, butter, jams, etc. in the Beverage mode or in the fridge. <p> NOTE</p> <ul style="list-style-type: none"> • Beverage Zone is for storing beverages, wines, and desserts that you plan to consume immediately. • The number of door openings, amount of stored foods, and temperature setting can affect the storage time.
AutoFill Pitcher *	<ul style="list-style-type: none"> • You can set the AutoFill Pitcher mode from one of the following modes. <ul style="list-style-type: none"> - On: Set to fill your water pitcher automatically. - Off: Set to turn off the function. <p> NOTE</p> <p>You can put tea or fruit into the infuser to make infused tea or water. If you want to keep the infused water in its initial concentration, turn the AutoFill Pitcher function off. (For more information, see the Water pitcher (AutoFill Pitcher) (applicable models only) section on page 57.)</p>
Cubed Ice *	You can start or stop making cubed ice.
Ice Bites *	You can start or stop making ice bites.

Sphere Ice *

- You can start or stop making ice spheres. The ice maker can make 3 ice spheres at once, and the ice maker can make 3 to 9 ice spheres every 24 hours.
- You can select the option from **3 spheres**, **6 spheres**, **9 spheres***, **Off**. (Default setting: **6 spheres**)
 - **3 spheres**: The ice maker makes 3 ice spheres approximately every 24 hours.
 - **6 spheres**: The ice maker makes 3 ice spheres approximately every 12 hours.
 - **9 spheres***: The ice maker makes 3 ice spheres approximately every 8 hours.
- The ice is more transparent if you choose the smaller amount.
- The ice maker stops making ice when it detects the full ice bucket (usually about 12 to 15 ice spheres, depending on how the ice spheres are stacked within the ice bucket).
 - To make new ice, make some room in the ice bucket by removing the ice spheres.
- The ice maker may stop making ice depending on the way ice spheres stack in the ice bucket. Arrange the ice spheres if too many ice spheres stack on one side of the bucket.
- The ice maker may not produce perfect sphere-shaped ice or you may notice air bubbles in the ice after the freezer has just been installed, the filter has been replaced, or if the power has been off for a certain time because of a power outage.
 - If you want to eliminate air bubbles in the ice, pour out the AutoFill Pitcher 6 times (about 12 liters).

CAUTION

- Make sure to put the sphere ice maker pad in the right direction. (For more information, see the **Auto Ice Maker** section on page **62**.)
 - The ice maker may stop making sphere ice if you remove the sphere ice maker pad from the ice bucket or if it is inserted in the wrong direction.

Operations

Settings	<p>You can change the settings for the following functions. Tap < or > to select the menu, and then tap OK to confirm.</p> <p>UV Deodorizing Filter *: You can turn the UV Deodorizing Filter on or off.</p> <p>Auto Open Door *: You can turn the Auto Open Door function on or off. (For more information, see the Auto Open Door function (applicable models only) on 55 page.)</p> <p>Water Filter Reset *: When you get the filter replacement message on the display, select this menu, and replace the filter according to onscreen instructions.</p> <p>Temp. Unit: You can set the temperature scale to Celsius or Fahrenheit.</p> <p>Peak Demand *: You can turn the Peak Demand function on or off. (For more information on Peak Demand function, see the SMART GRID Function (Demand Response) section on page 51.)</p> <p>Welcome Lighting: You can turn on or off the Welcome Lighting (For more information, see the Welcome Lighting (applicable models only) section on page 54.)</p> <p>Sounds: You can turn on or off the sound of the buttons (and Auto Open Door function*).</p> <p>Door Alarm: You can turn on or off the Door Alarm.</p> <p>Wi-Fi: You can turn on or off the Wi-Fi Connect. Turn it on to control and monitor your refrigerator on the SmartThings app. (For more information on SmartThings, see the SmartThings section on page 48.)</p>
----------	--

* applicable models only

 **NOTE**

Using Power Cool or Power Freeze increases energy consumption.

Activating or deactivating the Sabbath mode

The Sabbath mode stays active for 85 hours once it is activated. After that, it will be deactivated automatically.

- To activate or deactivate the Sabbath mode, tap and hold **OK** and **>** simultaneously for 6 seconds. Then, tap **>**.
 - When the refrigerator is in the Sabbath mode, the buttons, display, and internal lights do not function. The refrigerator and freezer, however, continue to cool.

NOTE

If the refrigerator powers off and restarts (for example, if there is a power failure), the Sabbath mode remains active. To end Sabbath mode, you must deactivate it as instructed above.

Activating or deactivating the Cooling Off mode

The Cooling Off mode (also called the Shop mode) is designed for retailers to display refrigerators on a retail floor. In the Cooling Off mode, the refrigerator's fan motor and lights operate normally, but the compressors do not run, so neither the refrigerator nor the freezer becomes cold.

- To activate or deactivate the Cooling Off mode, tap and hold **<** and **>** simultaneously for 6 seconds. Then, tap **OK**.
 - When the Cooling Off mode is on, the refrigerator chime sounds, and the refrigerator shows the **"Cooling Off mode turned on"** message.

Operations

SmartThings

Installation

Visit the Google Play Store, Galaxy Apps, or Apple App Store and search for “SmartThings”. Download and install the SmartThings app provided by Samsung Electronics to your smart device.

NOTE

- The supporting software version of the SmartThings app is subject to change according to the OS supporting policy the manufacturer provides. In addition, as for the SmartThings app or the functions that the app supports, the new application update policy on the existing OS version can be suspended due to usability or security reasons.
- The SmartThings app is subject to change without notice to improve usability or performance. As the mobile phone OS version is updated every year, the SmartThings is also updated continually according to the latest OS. If you have enquiries regarding the items mentioned above, please contact us on st.service@samsung.com
- Recommended encryption systems include WPA/TKIP and WPA2/AES. Any newer or unstandardized Wi-Fi authentication protocols are not supported.
- Wireless networks may be affected by the surrounding wireless communication environment.
- If your Internet service provider has registered the MAC address of your PC or modem for identification, your Samsung Smart Refrigerator may fail to connect to the Internet. If this happens, contact your Internet service provider for technical assistance.
- The firewall settings of your network system may prevent your Samsung Smart Refrigerator from accessing the Internet. Contact your Internet service provider for technical assistance. If this symptom continues, contact a local Samsung service center or retailer.
- To configure the wireless access point (AP) settings, see the user manual of the AP.
- Samsung Smart Refrigerators support both Wi-Fi 2.4 GHz with IEEE 802.11 b/g/n and Soft-AP protocols (IEEE 802.11 n is recommended).
- Unauthorized Wi-Fi wireless routers may fail to connect to applicable Samsung Smart Refrigerators.

Samsung account

You are required to register your Samsung account to use the app. If you don't have a Samsung account, follow the app's onscreen instructions to create a free Samsung account.

Getting started

Turn on the device you want to connect, open the SmartThings app on your phone, and then follow the instructions below.

If a pop-up appears saying that a new device has been found, tap **ADD NOW**.

If a pop-up doesn't appear, tap the **+** button, and then select the device you want to connect from the list of available devices.

If your device isn't in the list of available devices, tap **Supported Devices**, select the device type (Refrigerator), and then select the specific device model.

Follow the instructions in the app to set up your device. Once setup is complete, your refrigerator will appear as a "card" on your **Devices** screen.

Integrated control

You can monitor and control your refrigerator at home and on the go.

- Tap the refrigerator icon on the SmartThings Dashboard or tap the Devices icon at the bottom of the Dashboard, and then tap the refrigerator "card" to open the Refrigerator page.
- Check the operation status or notifications related to your refrigerator, and then change options or settings if necessary.

NOTE

Some options or settings of the refrigerator may not be available for remote control.

Operations

Category	Item	Description
Monitor & Control	Fridge Temperature	You can set and monitor the desired temperature of the fridge.
	Freezer Temperature	You can set and monitor the desired temperature of the freezer.
	Power Cool	You can turn Power Cool on or off, and check the current settings.
	Power Freeze	You can turn Power Freeze on or off, and check the current settings.
	FlexZone	You can set and monitor the desired mode of the FlexZone.
	Cubed Ice * Ice Bites * Sphere Ice *	You can turn the ice making function on or off, and check the current settings of the function.
	AutoFill Pitcher *	You can turn the AutoFill Pitcher function on or off, and check the current settings of the function.
Alarms	Abnormally high temperature	This alarm is triggered when the fridge, the freezer, or the FlexZone has abnormally high temperatures.
	Door opening	This alarm is triggered if the fridge door, the freezer drawer, or the FlexZone drawer is open for a specific time.
	AutoFill Pitcher overflowing *	If the AutoFill Pitcher function senses an overflow, it triggers this alarm to let you know the status of the overflow.
	Water filter replacement *	This alarm reminds you that the water filter must be replaced.
Inside Image *	You can view the inside of the refrigerator and can see if you need to replace food items.	

* applicable models only

Security updates information

Security updates are provided to strengthen the security of your device and protect your personal information. For more information on security updates, visit <https://security.samsungda.com>.

* The website supports only some languages.

SMART GRID Function (Demand Response)

(applicable models only)

When the refrigerator operates in SMART GRID (Demand Response) mode, the Energy Management function can control energy usage or delay the operation of some functions to save money when energy prices or demand are the highest.

In addition, to use the Smart Grid (Demand Response) function, you must register for the service with your electric company. The company must have an EMS (Energy Management System) that supports SEP (Smart Energy profile).

NOTE

- You can deactivate the SMART GRID (Demand Response) function at any time using the Peak Demand Off function.
- You can use monitor your energy consumption or turn energy-related features on and off using the SmartThings app. You must install the SmartThings app on your mobile device and connect the refrigerator to a Wi-Fi connection to use this feature.

Using the SMART GRID (Demand Response) Function

This feature monitors energy prices and demand information from your utility company and sends notifications to the refrigerator to run high energy consuming tasks during off-peak times when electricity costs and demand are lower.

If the refrigerator receives the SMART GRID (Demand Response) signal (**DAL** or **TALR**), the refrigerator will operate in Delay Appliance Load (**DAL**) or Temporary Appliance Load Reduction (**TALR**) mode.

Delay Appliance Load

The refrigerator responds to a **DAL** signal by providing a moderate load reduction for the duration of the delay period. This function controls functions that consume a lot of energy such as adjusting the Cooling system, running the defrost cycle, and making ice.

- **DAL** mode is automatically deactivated after it lasts for the amount of time stipulated by the **DAL** signal (max. 4.5 hours) or when the Peak Demand Off key is pressed.

Temporary Appliance Load Reduction

The refrigerator responds to a **TALR** signal by aggressively reducing the load for a short time period. This function reduces energy consumption by stopping the compressor and controlling the functions that consume a lot of energy such as the defrost cycle and making ice.

- **TALR** mode is automatically deactivated after it lasts for the received duration (max. 15 minutes), or when the Peak Demand Off key is pressed. The mode is immediately deactivated and the refrigerator returns to the normal state when the door is opened or closed, or the dispenser is used.

Operations

Peak Demand Off (Override mode)

When you want the refrigerator to ignore the SMART GRID (Demand Response) signal from the utility company, you can activate Peak Demand Off (Override mode).

When you activate Peak Demand Off (Override mode), the refrigerator ignores the SMART GRID (Demand Response) signal and is not controlled by the utility company.

You can activate or deactivate this mode from the main panel or on the SmartThings app.

Activating and deactivating Peak Demand Off (Override mode)

1. Tap any button (< , **OK** , or >) to wake up the display.
2. Tap < or > to select **Settings**, and then tap **OK** to confirm.
3. Tap < or > to select **Peak Demand**, and then tap **OK** to confirm.
4. Tap < or > to select **On** or **Off**, and then tap **OK** to confirm.

Energy management functions available on the SmartThings app

- Energy consumption monitoring (for the past and current month)
 - Shows the accumulated power consumption. Power consumption data is updated every 10 minutes.

NOTE

The energy consumption report may differ from the power consumption specifications of the product depending on the operating environment and the stored food.

- Demand response monitoring
- Activating/deactivating Peak Demand Off (Override) mode
- Defrost Delay
 - Delay Defrost saves energy by delaying the defrost operation in a 24-hour cycle to a time specified by the user. To change the delay time, use the Delay Defrost menu on the app. By default, the delay time is set as below:

November 1 to April 30	6 AM to 10 AM
May 1 to October 31	3 PM to 7 PM

Provision for Open Access to the Connected Product Requirements

1. SGIP Open Standards (Smart Energy Profile 2.0 - <http://www.csep.org/>)
 - Energy Consumption Reporting
 - Demand Response
2. Samsung OPEN API
 - Operational Status, User Settings & Messages
 - ICE Maker Status
 - Door Open Alarm
 - DR Status
 - Delay Defrost Capability
 - Set Schedule of the Defrost Delay
 - Get Schedule of the Defrost Delay
 - Delete Schedule of the Defrost Delay
 - Defrost Delay On/OFF

Special features

Beverage Center (applicable models only)

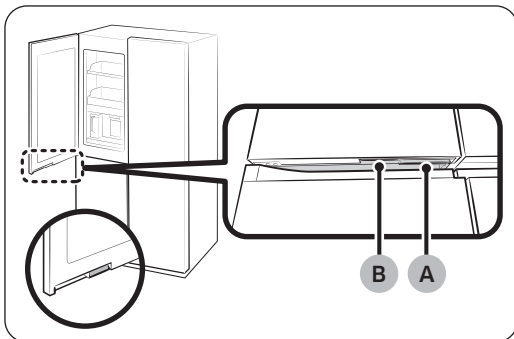

The left fridge door has two handles on the bottom. To use the AutoFill Pitcher, drink cold or purified water, press handle (B) to open the Beverage Center.

- A. Fridge door handle
- B. Beverage Center handle

Operations

Welcome Lighting (applicable models only)

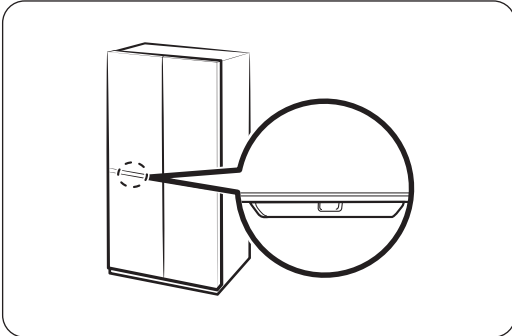

- When you get close to the refrigerator, the fridge light turns on automatically, allowing you to see inside the fridge without opening the doors.
 - There is a motion detection sensor on the underside of the fridge door.
 - The maximum time for the fridge light to stay on is 30 seconds.
- If you have installed the refrigerator for the first time or re-installed it, you must set the Welcome Lighting function to **On** from the main panel or the SmartThings app to use the function.
 - The default setting is **Off**.
- You can change the **Distance** and **Reaction time** settings of the **Welcome Lighting sensor** in the SmartThings app.
 - The default **Distance** setting is **Middle** (about 50 cm).
 - The default **Reaction time** setting is **Fast**.
 - You must be within the detection distance of the sensor for the Welcome Lighting to work.
 - The distance which the **Welcome Lighting sensor** detects can vary depending on the installation and usage environment in your home. (Approaching direction to the refrigerator, material, and color of the recognizable parts such as clothes, objects, etc., movement through the kitchen, etc.)

NOTE

- The Welcome Lighting can turn on even when a person or large pet walks past in front of the refrigerator.
- If the **Welcome Lighting sensor** detects an object, the Welcome Lighting may turn on and off. Move any object (such as a chair) away from the **Welcome Lighting sensor**.
- The **Welcome Light sensor** can be desensitized when it becomes dirty with foreign substances or dust. Regularly clean the sensor with a clean cloth.
- Highly reflective objects, such as mirrors, within the **Welcome Lighting sensor's** range can make the Welcome Lighting work from a distance.

Auto Open Door function (applicable models only)

The Auto Open Door function does not apply to the freezer doors.

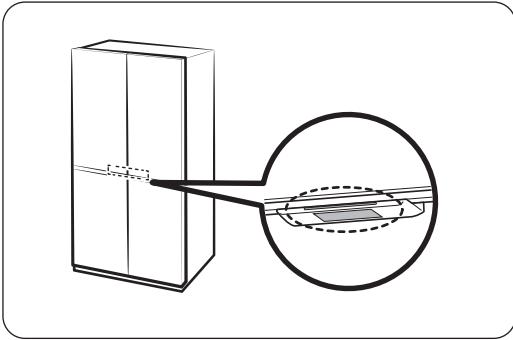

Touch the sensor near the door handle of the fridge. The door will open.

- The default setting is **Off**.
- To turn on the function, refer to the followings.
 - On the main panel, select **Settings > Auto Open Door** and select **On**.

NOTE

- If both sensors are touched simultaneously, the door that was touched first opens, and then the other door opens within about 2 seconds.
- The door does not close automatically. Close the door manually after use.
- The door opening angle depends on the following:
 - The level of the floor (left to right, front to back) where the refrigerator is installed.
 - The level of the refrigerator.
 - The amount of food stored in the door bins.
- If the doors open too wide, the unit is tilted too far forward. If one or both doors do not open far enough, the unit is tilted too far back. See the **Troubleshooting > Auto Open Door (applicable models only)** section on page **84** for the solution.

CAUTION

- The Auto Open Door function may malfunction if you open and close the door repeatedly.
- Do not push or force stop the door while it is opening automatically. It may cause the product to malfunction.
 - Be cautious not to get hit by the doors when they open automatically.
- If the door resists opening after repeated door opening, wait for about a minute and then try again. (It may be hard to open the door immediately after closing it due to air pressure change inside the refrigerator which occurs when you open and close the door.)
- Accidental touches to the sensor can cause the door to open, verify that it is closed.

Operations

AI Vision Inside (applicable models only)

- The AI Vision Inside does not support food management for the freezer.

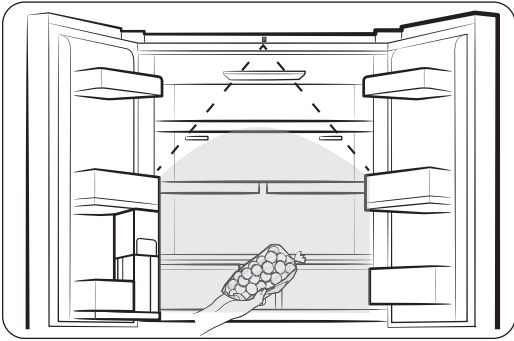

- You can manage the food coming in and out of the fridge using the camera on the top part of the fridge.
 - To use this feature, your refrigerator must be connected to a network through SmartThings.
 - You must complete the initial setup of the camera to use it.
- It checks food stored on the fridge shelves and door bins, or alerts you about the food that is nearing the expiration date.
- When you open the fridge door, it is recommended that you put food in or out of the fridge after hearing the recognition beep. Pause for a moment or move slowly within the camera range.
 - If you put several foods in the fridge at once, they will be registered as one food, so please put them separately.
 - When you take out a food, let the same side exposed to the camera as when you put it, and it must not be covered by more than 65%.

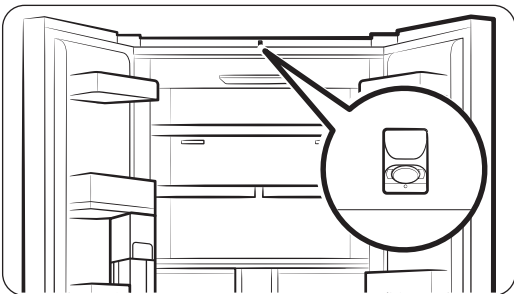

⚠ CAUTION

Do not get close to the camera. Otherwise, you will be photographed of your body.

- If you do not wish to use the AI Vision Inside feature, turn off the AI Vision Inside camera on the AI Vision Inside app's settings or cover the AI Vision camera with a sticker.

NOTE

- If the fridge lights are turned off or the surroundings are dark, its recognition rate may be lower.
- Ensure that the characteristics of an incoming item such as food are clearly visible (so clearly distinguished from other items), which can improve the accuracy of incoming/outgoing matching.
- Food in storage containers can be written in large and bold letters to help with incoming/outgoing matching.

Water pitcher (AutoFill Pitcher) (applicable models only)

Cold, purified water is always ready in the AutoFill Pitcher. You can put tea or fruits in the infuser to enjoy the various infused water you like.

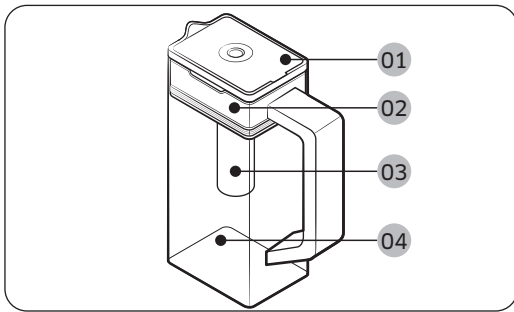

- 01** Lid
- 02** Infuser holder
- 03** Infuser
- 04** Body

To fill the Water pitcher

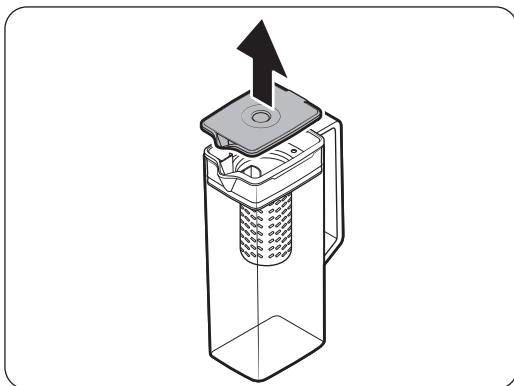

1. Grasp a handle groove of the lid, and then pull up to open the lid.
2. Put tea leaves or fruit to your taste into the infuser.

NOTE

If you want to keep the infused water in its initial concentration, turn the AutoFill Pitcher function off.

Operations

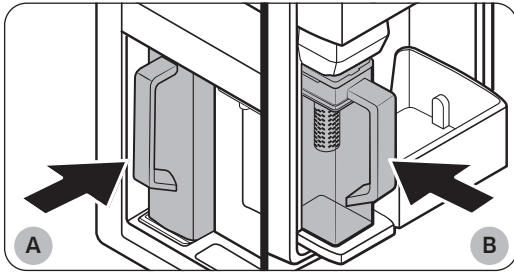

- A. Type A models
- B. Type B models

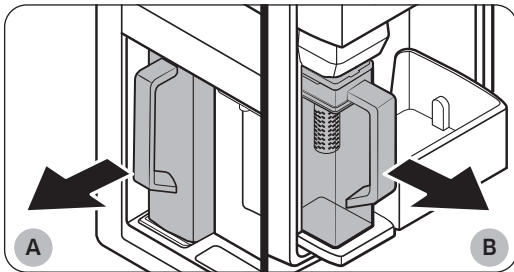

- A. Type A models
- B. Type B models

⚠ CAUTION

- We recommend consuming fruit infused water within 24 hours. After that, the infused water can spoil over time.
- You must clean the water pitcher after you have consumed the infused water. Also clean the water pitcher if you haven't used it for a long time.

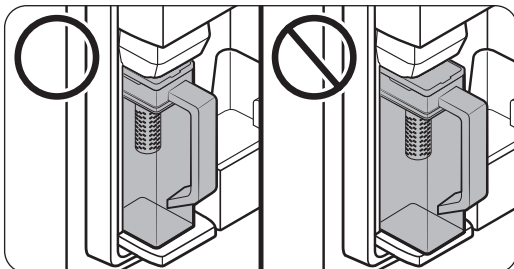

3. Enable the AutoFill Pitcher function on the main panel. Open the Beverage Center door (Type A) or the left door of the fridge (Type B), and then mount the water pitcher onto the holder. Push it straight in as shown in the figure.

⚠ CAUTION

Make sure the water pitcher fits in the water pitcher holder.

4. Close the door. The water pitcher will start to fill with chilled water a short time later.
5. To drink tea, open the Beverage Center door (Type A) or the left door of the fridge (Type B), and then detach the water pitcher. Pull it straight out.

- To prevent the water pitcher from tipping over or leaking, make sure the water pitcher fits in the water pitcher holder.

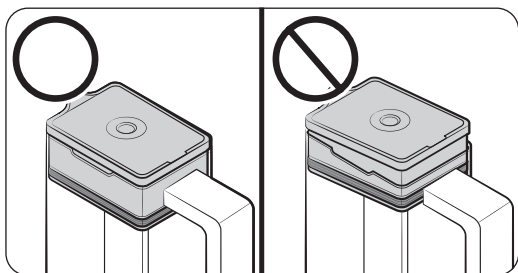

- To prevent the water pitcher from spilling over or leaking, make sure the infuser holder is properly inserted.

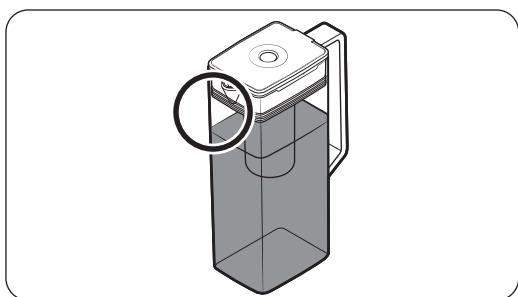

 **NOTE**

- If the front side (specifically marked area) of the water pitcher has too much moisture, the water pitcher may not fully fill. Remove the moisture, and then try again.
- AutoFill Pitcher function will stop supplying water to the water pitcher if the water pitcher does not fill after a certain amount of time. If this happens, check if the water line is properly connected. Remove and reinsert the water pitcher, and then try again.

Operations

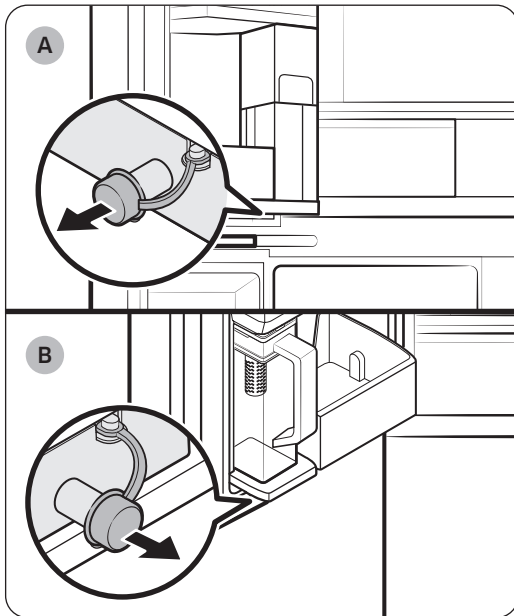

A. Type A models

B. Type B models

NOTE

- You must clean the water pitcher after you have consumed the infused water. You must also clean the water pitcher if you have not used it for a long time or left the full pitcher for more than three days.
- If the infuser is not properly cleaned, the scent of the tea or fruits you previously used in the infuser may remain. If you are not going to use the infuser, separate it from the pitcher and store it safely.
- If you have not used the water filter for a long time, pour away the first two pitchers of water. Then, clean the water pitcher thoroughly and use it.

- Wipe around the water pitcher holder if the water pitcher overflows or leaks.
- Water drops off if the rubber cap is opened.
- An alert appears on the main panel if there is a leak. In case of a leak, open the rubber cap so that the leaked water drains. If the alert does not disappear after draining, there might be a system failure. Contact your local Samsung service center.

Water dispenser (applicable models only)

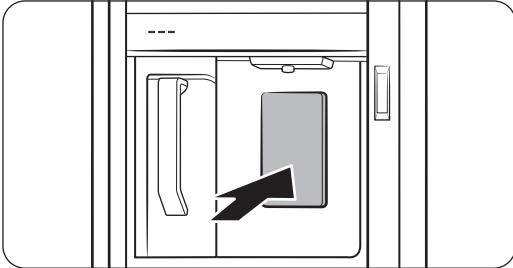

To dispense chilled water, open the Beverage Center and press the dispenser lever.

NOTE

- The dispenser will stop dispensing if you keep pushing the dispenser lever for about 1 minute. To dispense more water, release and push the lever again.
- Make sure the glass is in line with the dispenser to prevent the dispensed water from spilling out.
- If you do not use the water dispenser for 2-3 days, the dispensed water may have an abnormal smell or taste. This is not a system failure. Discard the first 1-2 glasses of water.

Water clouding

Water supplied to the refrigerator flows through a core alkaline filter. During this filtering process, the water pressure of the water increases and the water becomes saturated with oxygen and nitrogen. This causes the water to look misty or cloudy temporarily when dispensed. This is normal and the water will look clear after a few seconds.

Operations

Auto Ice Maker

The refrigerator has a built-in ice maker that automatically dispenses ice.

- The overall design and/or accessories may differ with the model.

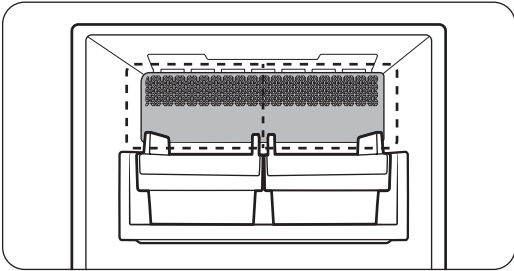

⚠ WARNING

Choking hazard: Ice may cause choking in small children.

⚠ CAUTION

After using the ice scoop, do not leave it in the ice bucket.

For first-time use

- Let the ice maker make ice for 1-2 days.
- Discard the first 1-2 buckets of ice to remove impurities in the water supply system.

Cubed ice/ice bites and sphere ice maker (applicable models only)

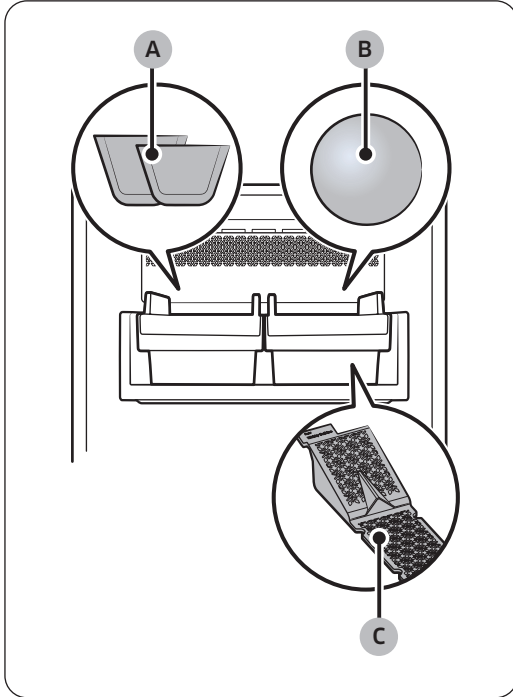

- A. Cubed ice * or ice bites *
- B. Sphere ice
- C. Sphere ice maker pad

CAUTION

- Do not put your finger into the ice maker.
- Do not freeze water directly in the ice bucket. The ice bucket can get damaged.
- If you leave the door open too long, ice in the ice bucket may melt and clump together.
- If the ice inside the ice bucket melts into water (because of a power outage, etc.) empty the ice bucket. Otherwise, it may cause the ice bucket to break when the water refreezes.
- When the Ice function is on, the ice maker will keep making ice even if there is no ice bucket in place. Make sure you turn off the function if you do not want to make ice.

NOTE

- Empty the ice bucket regularly.
 - Newly produced ice may clump with old ice, and old ice may stick to the ice bucket.
- The size, shape, and transparency of the ice may vary depending on the water pressure and the usage condition (such as ambient temperature, freezer temperature, and frequency of the door opening).
- You may hear a sound when the ice drops into the ice bucket.

Operations

- Hold the ice bucket with both hands when you remove it from the freezer to prevent dropping it.

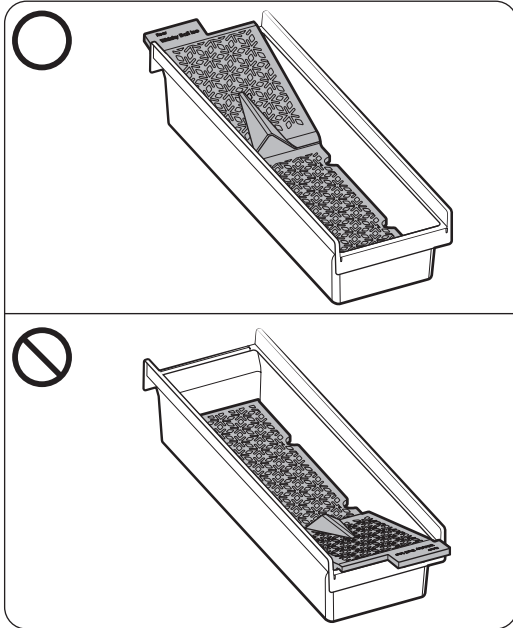

- Make sure to put the sphere ice maker pad in the right direction, and do not get it mixed up with the cubed ice maker pad.
 - The ice maker may stop making sphere ice if you remove the sphere ice maker pad from the ice bucket or if it is inserted in the wrong direction.
 - Place the side with the letter 'Rear' on the pad and ice bucket in the same direction.

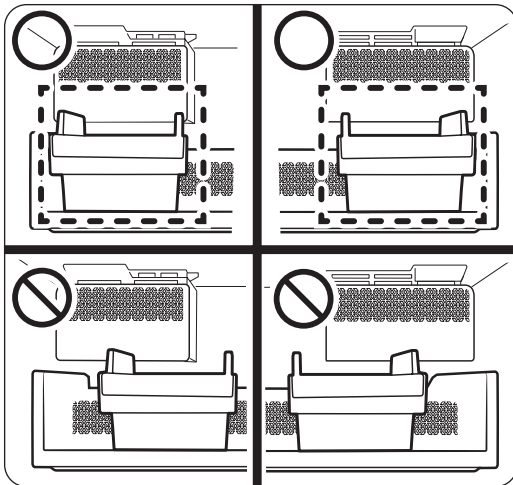

- Check the position of the ice bucket before using each ice maker.
 - Place the ice bucket against the wall directly underneath the ice maker. If the ice bucket is not directly underneath the ice maker, the ice maker may not make ice.

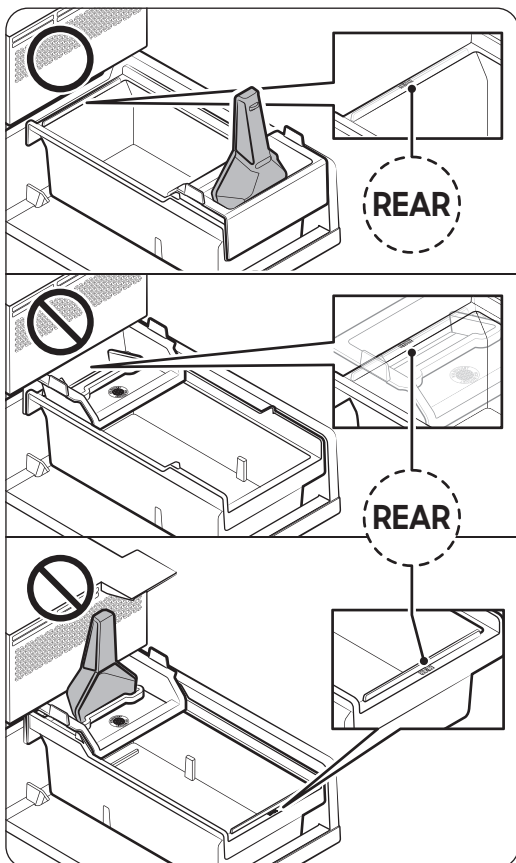

- Place the ice bucket under the ice maker with the side marked 'REAR' facing the back.
- Place the scoop holder at the front of the ice bucket.

⚠ CAUTION

Ice may not be produced if the scoop holder and ice bucket are not positioned correctly.

Diagnosis

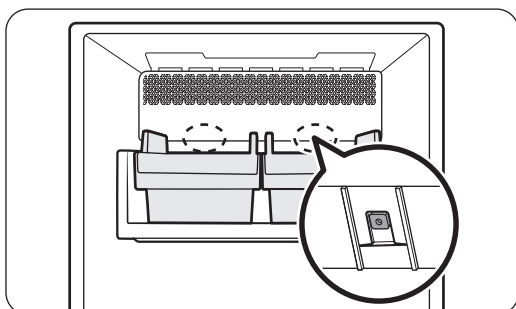

- The overall design and/or accessories may differ with the model.
- If ice does not dispense, first check the status of ice maker using the **Test** button on the bottom of the ice maker.
- Press the **Test** button on the bottom of the ice maker. You will hear a chime (ding-dong) when you press the button. You will hear another chime if the ice maker is operating properly.

Operations

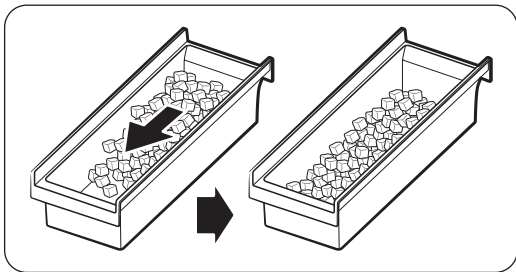

- Ice accumulating on one side of the tray is normal. Arrange the ice evenly in the tray to store more ice.

CAUTION

- Leaving the water line disconnected may cause the water valve to produce a buzzing sound over time. If this is the case, make sure to turn the ice making function off.
- If the ice making chime rings repeatedly, contact the waterline installer or a local Samsung service center.
- Do not put food in the ice bucket. The frozen food may damage the ice maker, especially when you open or close the door.
- When the refrigerator recovers power after a power failure, the ice bucket may contain a mix of melted and jammed ice cubes, which can prevent the ice maker from working properly. To prevent this, make sure to empty the ice bucket before using the refrigerator.
- Do not put fingers or any objects into the ice maker. This can cause physical injury or property damage.
- Ice stored in the freezer for a long time gets smaller and then forms large ice chunks caused by sublimation. Therefore, if you are not planning to use the ice maker for a long time, turn it off and empty the ice bucket.
- Use the new hose-sets supplied with the appliance only. Do not re-use an old hose set.

Maintenance

Handling and care

Ice bucket (applicable models only)

If you do not dispense ice for an extended period, ice may form clumps inside the bucket. If this happens, remove and empty the ice bucket.

CAUTION

- To prevent injury, make sure to clean up any ice or water that has fallen on the floor.
- To prevent accidents or injury, do not let children play with the water dispenser or the ice maker.
- Use only the provided ice bucket. Third-party ice buckets may cause a system failure.

NOTE

Noise from the ice maker as it produces ice during the ice making process is normal.

Maintenance

AutoFill Pitcher (applicable models only)

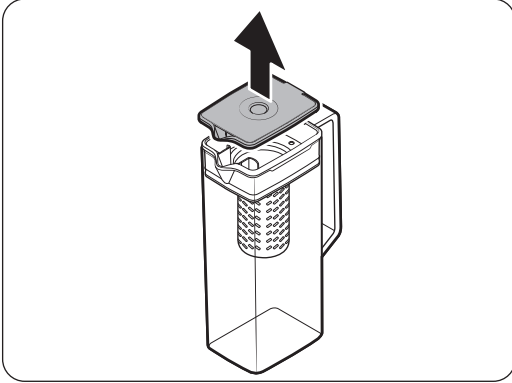

1. Grasp a handle groove of the lid, and then pull up to remove.

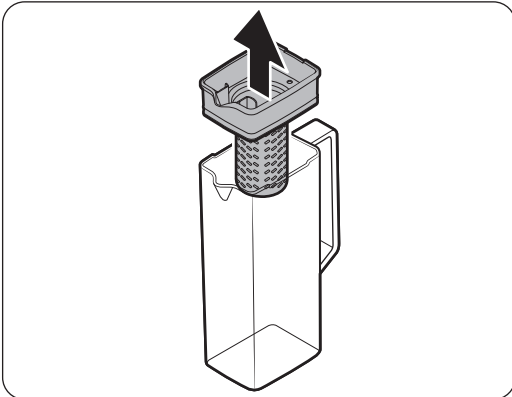

2. Grasp both sides of the infuser holder, and then lift to remove.

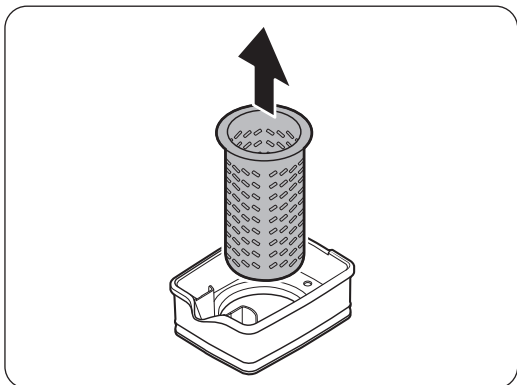

3. While slightly twisting the **infuser**, pull it out of the sealed mouth.
4. Clean the **infuser** with neutral agents and running water. Rinse and dry well.
5. Reassemble the AutoFill Pitcher in the reverse order of disassembly.

⚠ CAUTION

The water pitcher and lid are not microwave safe and can melt or deform if exposed to heat (including hot water). It is dishwasher safe in cycles with water temperatures below 158 °F (70 °C). Do not use in dishwasher cycle over 158 °F (70 °C), and do not stack dishes or cups on the pitcher when using dishwasher. Please hand wash in cool or warm water as needed.

Maintenance

Fridge shelves

The appearance of the shelves differs by model.

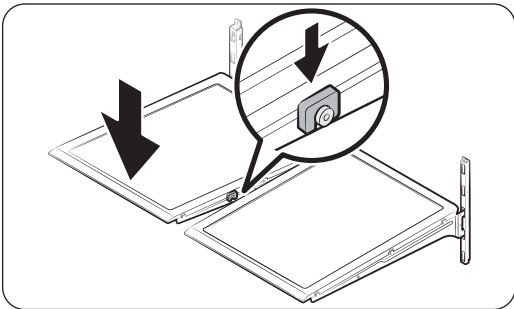
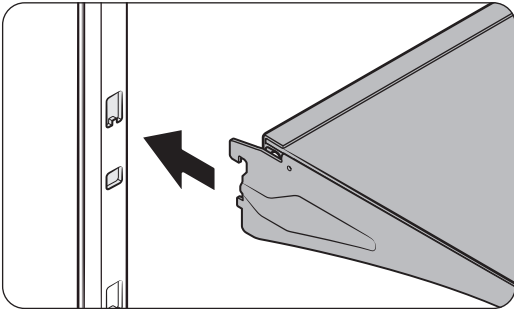
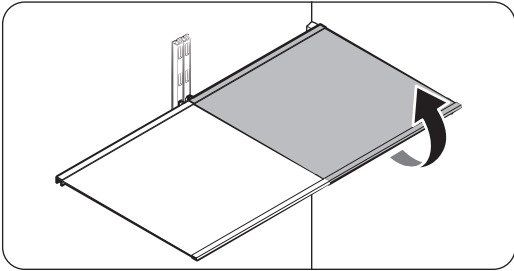

- To remove a shelf, fully open the corresponding door. Hold the front of the shelf, and then gently lift up and pull out.

NOTE

Do not lift up the shelf fully when removing or reinserting the shelf. The rear wall of the fridge room can be dented.

- To reinsert, hold the shelf at an angle so the front is higher than the back, and then insert the top hook into the top shelf notch. Then, lower the shelf and insert the bottom shelf hook into the bottom shelf notch.

CAUTION

- The tempered glass shelves are heavy. Use caution when removing them.
- The shelf must be inserted correctly. Do not insert upside down.
- Glass containers may scratch the surface of glass shelves.

Door bins

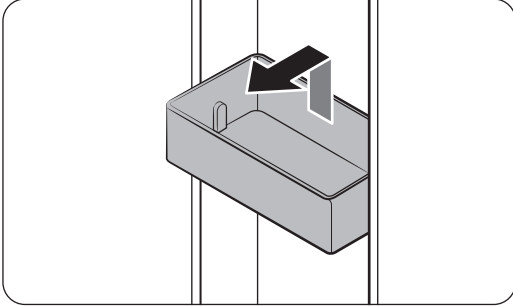

- To remove the **door bin**, hold the front sides of the bin, and then gently lift up to remove.
- To reinsert, insert the **door bin** slightly above its final location making sure that the back of the bin is against the door. Hold the rear of the **door bin** with both hands, and then press down so that it fits snugly.

CAUTION

- Do not remove a bin that is filled with food. Empty the bin beforehand.
- Use caution when opening the door if the bottom bin contains larger bottles, which may fall over.
- Do not allow children to play with the bins. Sharp corners of the bin may cause injury.

Fridge drawers

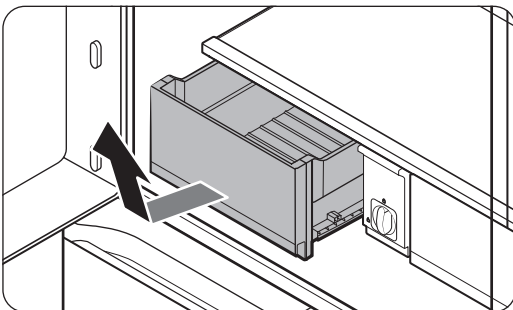

Gently lift up the front of the drawer and slide out.

- We recommend that you remove the door bins before removing the drawer. This is to prevent damage to the door bins.
- To reinsert, insert the drawer into the frame rails and then slide inward.

Maintenance

Beverage Zone (applicable models only)

You can select the **Beverage** or **Wine/Dessert** mode. Store items that are suitable for the selected mode.

Disassembling the Beverage Zone

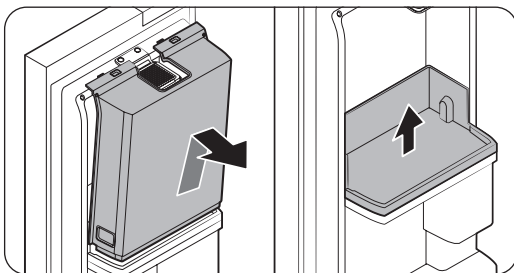
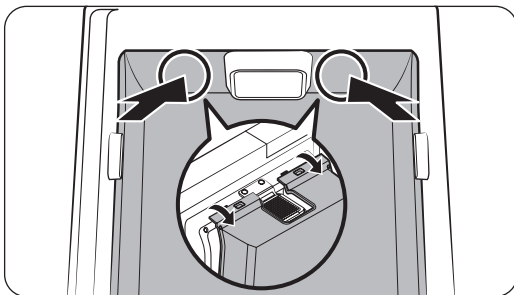
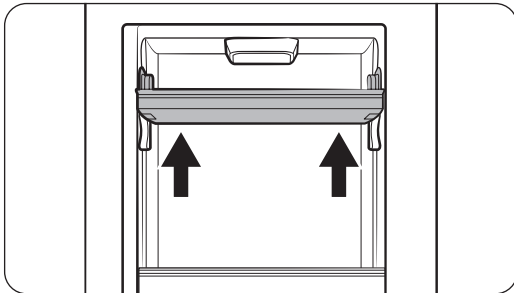

1. Open the left **Showcase door**, and then hold the upper door bin with both hands and lift up to remove it.
2. With the left **Showcase door** open, open the fridge door. Then, push the upper part of the **Beverage Zone** (left and right side of the fan) from inside to release the snap joints securing the **Beverage Zone cover** to the door.
3. If the snap joints at the upper part are released, hold the **Beverage Zone cover** and lift it to remove it.
 - After disassembling the **Beverage Zone cover**, you can hold the lower door bin with both hands and lift it to remove it.

Assembling the Beverage Zone

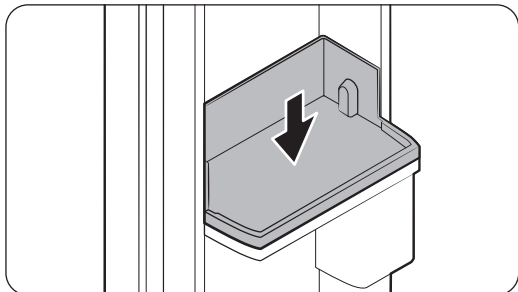

1. With the fridge door or the **Showcase door** open, align the grooves on the left and right side of the bottom door bin, and then insert it.

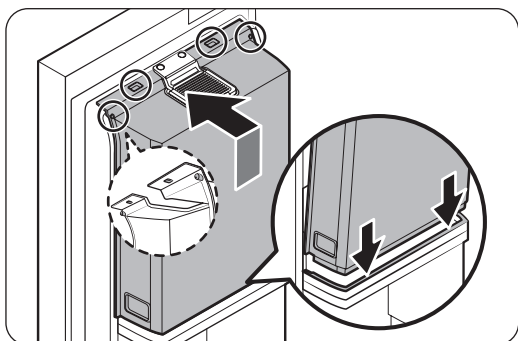

2. Open the fridge door, and then assemble the snap joints at the bottom and top of the **Beverage Zone cover** in order. (Reversed order of the disassembly)
 - To assemble the upper door bin, open the **Showcase door**, align the grooves on the left and right side, and then insert it.

Maintenance

Cleaning

Interior and exterior

WARNING

- Do not use benzene, thinner, vinegar, liquid bleach, baking soda, citric, salt mixtures or home/car detergent such as Clorox™ for cleaning purposes. They may damage the surface of the refrigerator and cause a fire.
- Do not spray water onto the refrigerator. This may cause electric shock.

Regularly use a dry cloth to remove all foreign substances such as dust or water from the power plug terminals and contact points.

1. Unplug the power cord.
2. Use a moistened, soft, lint-free cloth or paper towel to clean the refrigerator's interior and exterior.
3. When done, use a dry cloth or paper towel to dry well.
4. Plug in the power cord.

Inner-view camera (applicable models only)

NOTE

Use a cotton swab or microfiber cloth to clean the camera on the top part of the fridge (with the fridge door open).

Dispenser nozzle (applicable models only)

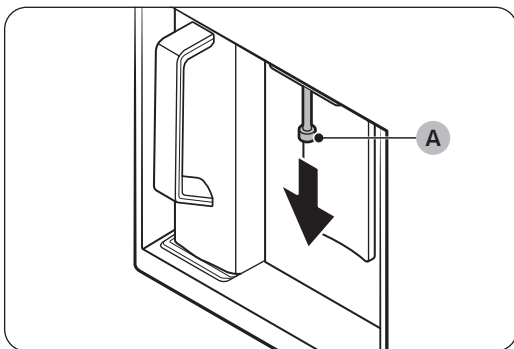

1. Hold the end of the dispenser nozzle (A).
2. While turning the dispenser nozzle (A) left, pull it down to remove it from the dispenser.

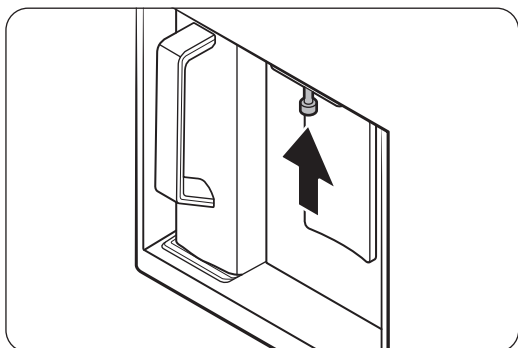

3. Clean the dispenser nozzle thoroughly, and then assemble it back.

⚠ CAUTION

- Fully insert the dispenser nozzle, so it is back to its original position.
- Do not use a sponge with rough textures for cleaning the dispenser nozzle.

Rubber seals

If the rubber seals of a door become dirty, the door may not close properly and reducing refrigerator performance and efficiency. Use a mild detergent and damp cloth to clean the rubber seals. Then, dry well with a cloth.

Rear panel

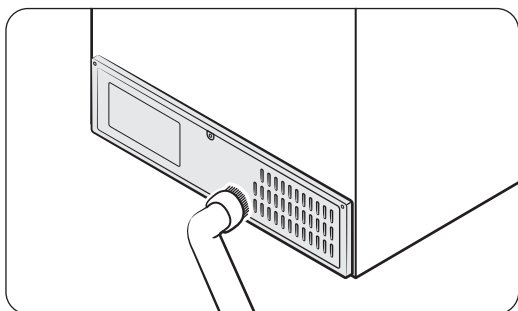

To keep cords and exposed parts of the rear panel free of dirt, vacuum the panel once or twice a year.

⚠ CAUTION

Do not remove the rear panel cover. Electric shock may occur.

Maintenance

Mesh filter (applicable models only)

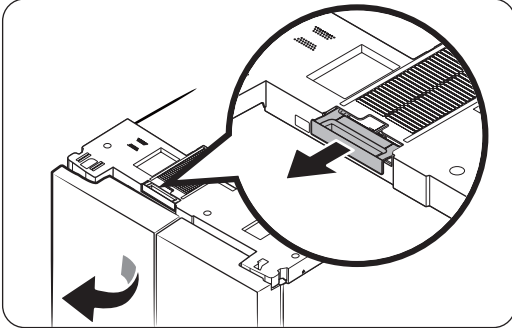

- Open the left door of the fridge and remove the mesh filter located at the top of the refrigerator.
 - After removing the dust, gently wash the filter with lukewarm water mixed with neutral detergent.

NOTE

- Dust may fall off when detaching the filter.
- The mesh filter may get damaged if you scrub it with a brush or wash it with hot water.
- If there is a strong odor or severe contamination, soak the filter in lukewarm water mixed with neutral detergent for about 30 minutes before rinsing.
- After completely drying the filter, insert it into its place with the **filter handle (A)** facing outward.
 - When drying the filter, avoid direct sunlight and allow it to dry thoroughly in the shade.

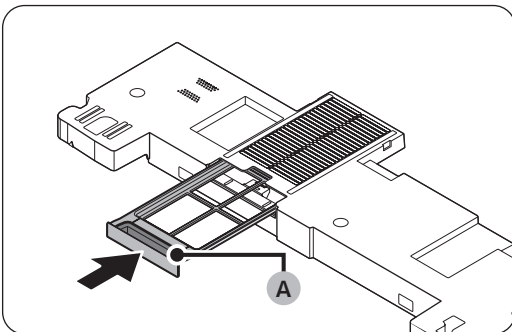

Replacement

Water filter (applicable models only)

WARNING

- Use only Samsung brand replacement water filter.
 - Genuine Samsung replacement filters are equipped with a QR code for verification.
 - Always ensure the filter's authenticity by scanning the QR code.
- Third Party or counterfeit filters may be subject to cracking/leaking that could lead to property damage.
- Samsung is not responsible for any damage that may occur from use of third-party or counterfeit water filters.

NOTE

When the water filter is removed, water will not be supplied and therefore the ice maker and dispenser will not operate.

The “**Replace water filter**” message appears on the main panel to let you know it is time to replace the water filter. Before replacing the filter, make sure the main water supply is shut off.

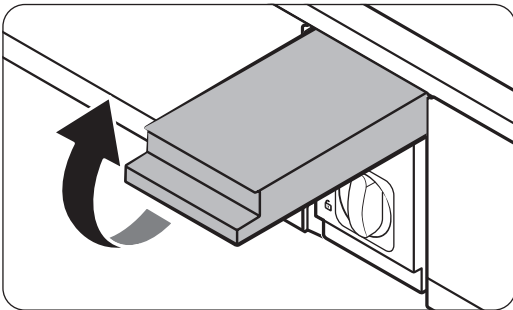

1. Shut off the main water supply.
2. Open the filter cartridge cover.

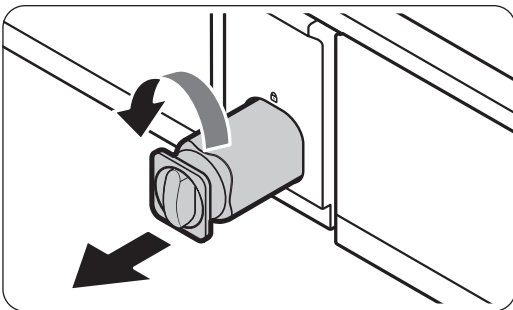

3. Turn the knob of the filter cartridge counter clockwise 90 degrees ($\frac{1}{4}$ turn). The filter cartridge unlocks.

Maintenance

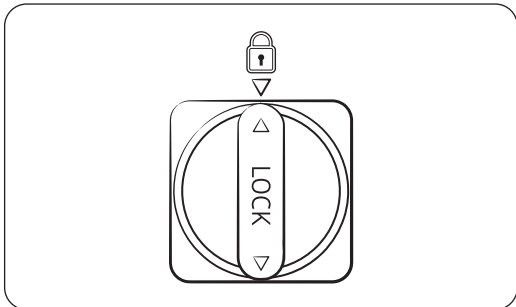
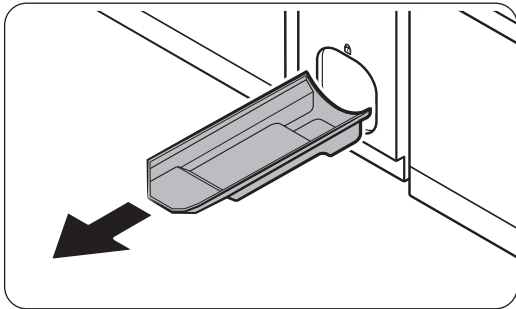

4. Pull out to remove the cartridge.
 - If the water filter is severely contaminated, the cartridge may not be easy to remove. If that is the case, use force to remove the cartridge.
 - To prevent water leaks from the filter opening, pull the cartridge straight out while removing it.
5. Insert a new filter cartridge. Use only Samsung-provided or approved filters.
6. Turn the cartridge knob clockwise to lock into place.
7. Close the filter cartridge cover.
8. Reset the filter on the main panel.
 - On the main panel, go to **Settings**, and then run **Filter Reset**.

NOTE

- A newly installed filter may cause the water dispenser to spurt water briefly. This is because air has entered the waterline.
- The replacement process may cause the water dispenser to drip for a short period of time. If it drips, simply wipe up any water on the floor with a dry towel.

Reverse osmosis water filtration system

The water pressure of the water supply system to a reverse osmosis water filtration system must be between 30-125 psi (206-861 kPa).

The water pressure of the reverse osmosis water filtration system to the refrigerator's cold water line must be at least 30 psi (206 kPa). If the water pressure is below these specifications:

- Check if the sediment filter in the reverse osmosis system is blocked. Replace the filter if necessary.
- Refill the water tank in the reverse osmosis system with water.

For more information or servicing, contact a licensed plumbing professional.

Ordering a new filter

To purchase a new water filter, contact a local Samsung service center or visit www.samsung.com/us on the web.

LED Lamps

To replace the lamps of the refrigerator, contact a local Samsung service center.

WARNING

- The lamps are not user-serviceable. Do not attempt to replace a lamp yourself. This can cause electric shock.

Troubleshooting

Before calling for service, review the symptoms and recommended solutions below. If none of the suggested solutions resolve your problem, please visit our website at www.samsung.com or call Samsung Customer Care at 1-800-SAMSUNG (726-7864). Note that you will be charged for any service visits in which no defects were found.

General

Temperature

Symptom	Possible causes	Solution
Fridge/freezer does not operate. Fridge/freezer temperature is warm.	<ul style="list-style-type: none"> Power cord is not plugged in properly. 	<ul style="list-style-type: none"> Properly plug in the power cord.
	<ul style="list-style-type: none"> Temperature control is not set correctly. 	<ul style="list-style-type: none"> Set the temperature lower.
	<ul style="list-style-type: none"> Refrigerator is located near a heat source or direct sunlight. 	<ul style="list-style-type: none"> Keep the refrigerator away from direct sunlight or a heat source.
	<ul style="list-style-type: none"> Not enough clearance between refrigerator and nearby walls or cabinets. 	<ul style="list-style-type: none"> We recommend that the gap between the refrigerator and nearby walls (or cabinets) is more than 2" (50 mm).
Fridge/freezer is over-cooling.	<ul style="list-style-type: none"> The refrigerator is overloaded. Food is blocking the refrigerator vents. 	<ul style="list-style-type: none"> Do not overload the refrigerator. Do not allow food to block vents.
	<ul style="list-style-type: none"> Temperature control is not set correctly. 	<ul style="list-style-type: none"> Set the temperature higher.

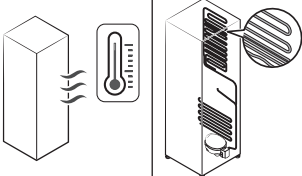
Symptom	Possible causes	Solution
Interior wall is hot.	<ul style="list-style-type: none"> Refrigerator has heat-proof piping in the interior wall. 	<ul style="list-style-type: none"> To prevent condensation from forming, the refrigerator has heat-proof piping in the front corners. If the ambient temperature rises, this equipment may not work effectively. This is not a system failure. 

Odors

Symptom	Possible causes	Solution
Refrigerator has odors.	<ul style="list-style-type: none"> Spoiled food. 	<ul style="list-style-type: none"> Clean the refrigerator and remove any spoiled food.
	<ul style="list-style-type: none"> Food with strong odors. 	<ul style="list-style-type: none"> Make sure strong smelling food is wrapped airtight.

Frost

Symptom	Possible causes	Solution
Frost around the vents.	<ul style="list-style-type: none"> Food is blocking the vents. 	<ul style="list-style-type: none"> Make sure no food blocks the refrigerator vents.
Frost on interior walls.	<ul style="list-style-type: none"> Door is not closed properly. 	<ul style="list-style-type: none"> Make sure food does not block the door. Clean the door gasket.
Fruits or vegetables are frozen.	<ul style="list-style-type: none"> Fruits or vegetables are stored in the FlexZone. 	<ul style="list-style-type: none"> Do not store most kinds of fruit or vegetables in the FlexZone.

Troubleshooting

Condensation

Symptom	Possible causes	Solution
Condensation forms on the interior walls.	<ul style="list-style-type: none"> If door is left open, moisture enters the refrigerator. 	<ul style="list-style-type: none"> Remove the moisture and do not leave a door open for extended periods of time.
	<ul style="list-style-type: none"> Food with high moisture content. 	<ul style="list-style-type: none"> Make sure food is wrapped airtight.

Water/ice (dispenser models only)

Symptom	Possible causes	Solution
Water flow is weaker than normal.	<ul style="list-style-type: none"> Water pressure is too low. 	<ul style="list-style-type: none"> Make sure the water pressure is between 30-125 psi (206-861 kPa).
Ice maker makes a buzzing sound.	<ul style="list-style-type: none"> The ice maker function is activated, but the water supply to the refrigerator has not been connected. 	<ul style="list-style-type: none"> Turn off the Ice Maker.
Ice maker does not make ice.	<ul style="list-style-type: none"> Ice maker has just been installed. 	<ul style="list-style-type: none"> You must wait for 24 hours for the refrigerator to make ice.
	<ul style="list-style-type: none"> Freezer temperature is too high. 	<ul style="list-style-type: none"> Set the freezer temperature below 0 °F (-18 °C) or -4 °F (-20 °C) in warm ambient air.
	<ul style="list-style-type: none"> Ice maker is off. 	<ul style="list-style-type: none"> Turn on the ice maker.
	<ul style="list-style-type: none"> Ice scoop or holder remains in the Ice bucket. 	<ul style="list-style-type: none"> Please keep the ice scoop in the front holder.

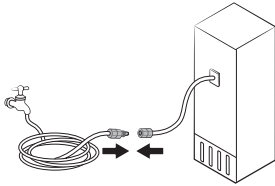
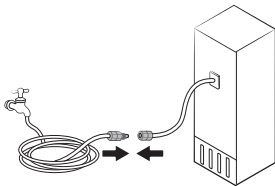
Symptom	Possible causes	Solution
Ice does not dispense.	<ul style="list-style-type: none"> Ice may jam if the ice dispenser is not used for a long time (approx. 3 weeks). 	<ul style="list-style-type: none"> If you won't be using the refrigerator for a long time, empty the ice bucket and turn off the ice maker.
	<ul style="list-style-type: none"> Ice bucket is not properly inserted. 	<ul style="list-style-type: none"> Make sure the ice bucket is properly inserted.
	<ul style="list-style-type: none"> Water line is not connected properly or water supply is not on. 	<ul style="list-style-type: none"> Check the water installation conditions. 
Water does not dispense.	<ul style="list-style-type: none"> Water line is not connected properly or water supply is not on. 	<ul style="list-style-type: none"> Check the water installation conditions. 
	<ul style="list-style-type: none"> A third-party water filter was installed. 	<ul style="list-style-type: none"> Use only Samsung-provided or approved filters. Unapproved filters may leak and damage the refrigerator.
	<ul style="list-style-type: none"> The "Replace water filter" message appears on the main panel. 	<ul style="list-style-type: none"> Replace the water filter. Then on the main panel, go to Settings, and then run Filter Reset.

Troubleshooting

Auto Open Door (applicable models only)

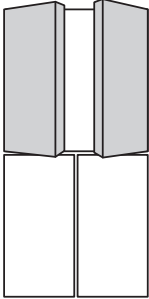
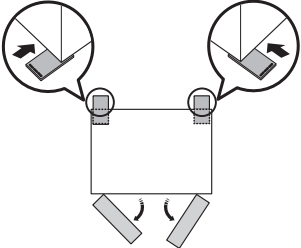
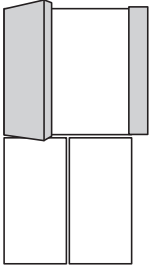
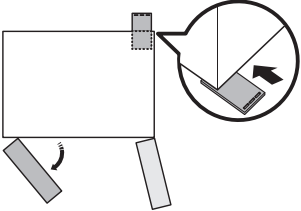
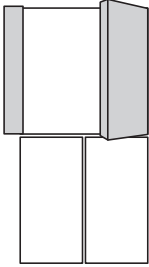
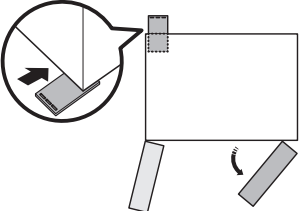
Symptom		Possible causes	Solution
The fridge doors do not open wide enough.	Both doors 	<ul style="list-style-type: none"> The rear sides of the refrigerator are low. 	<ul style="list-style-type: none"> Raise the rear sides of the refrigerator to level it. * 
	Left door 	<ul style="list-style-type: none"> The rear-right side of the refrigerator is low. 	<ul style="list-style-type: none"> Raise the rear-right side of the refrigerator to level it. * 
	Right door 	<ul style="list-style-type: none"> The rear-left side of the refrigerator is low. 	<ul style="list-style-type: none"> Raise the rear-left side of the refrigerator to level it. * 

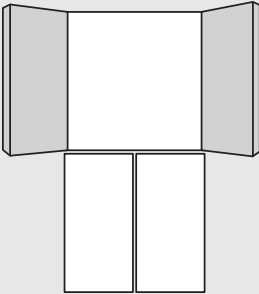
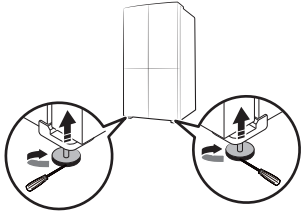
Symptom	Possible causes	Solution
<p>The fridge doors open too wide.</p> 	<ul style="list-style-type: none"> The front sides of the refrigerator are low. 	<ul style="list-style-type: none"> Raise the front sides of the refrigerator to level it. * 

* For more information on leveling the refrigerator, see the “STEP 5 Leveling the refrigerator” section on page 32.)

Troubleshooting

Do you hear abnormal sounds from the refrigerator?

Before calling for service, review the information below. If you still have questions about sounds your refrigerator is making, please call Samsung Customer Care at 1-800-SAMSUNG (726-7864). Note that you will be charged for any service visits related to normal operating sounds in which no defects were found.

These sounds are normal.

- When starting or ending an operation, the refrigerator may make sounds similar to a car engine ignition. As the operation stabilizes, the sounds will decrease.

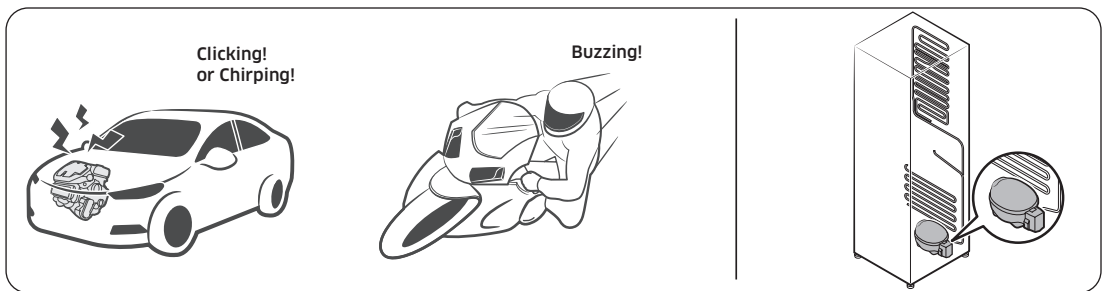

- While the fan is operating, these sounds may occur. When the refrigerator reaches the set temperature, the fan sound will stop.



- During a defrost cycle, water may drip on the defrost heater, causing sizzling sounds.



- As the refrigerator cools or freezes, refrigerant gas moves through sealed pipes, causing bubbling sounds.

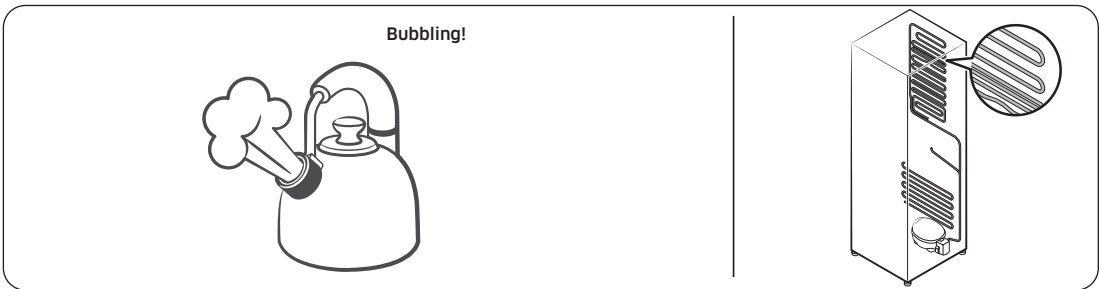

- As the refrigerator temperature increases or decreases, plastic parts contract and expand, creating knocking noises. These noises occur during the defrosting cycle or when electronic parts are working.

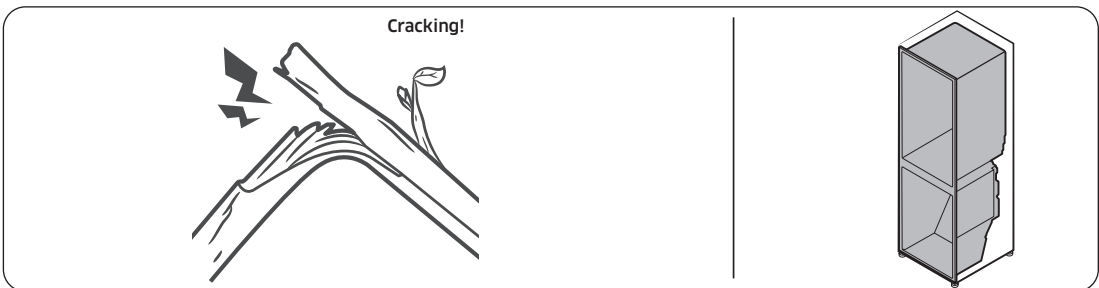

- For ice maker models: When the water valve opens to fill the ice maker, you may hear a buzzing sound.
- Due to pressure equalizing when you open and close the refrigerator door, you may hear a whooshing sound.

Troubleshooting

SmartThings

Symptom	Action
Could not find "SmartThings" in the app market.	<ul style="list-style-type: none">The supporting software version of the SmartThings app is subject to change according to the OS supporting policy the manufacturer provides. In addition, as for the SmartThings app or the functions that the app supports, the new application update policy on the existing OS version can be suspended due to usability or security reasons.
The SmartThings app fails to operate.	<ul style="list-style-type: none">The SmartThings app is available for applicable models only.The old Samsung Smart Refrigerator app cannot connect with Samsung Smart Home models.
The SmartThings app is installed but is not connected to my refrigerator.	<ul style="list-style-type: none">You must log into your Samsung account to use the app.Make sure that your router is operating normally.If you have not connected your refrigerator to the SmartThings App after the app was installed, you must make the connection using the device registration function of the app.
Could not log into the app.	<ul style="list-style-type: none">You must log into your Samsung account to use the app.If you don't have a Samsung account, follow the app's onscreen instructions to create one.
An error message appears when I try to register my refrigerator.	<ul style="list-style-type: none">Easy Connection may fail due to the distance from your access point (AP) or electrical interference from the surrounding environment. Wait a moment and try again.
The SmartThings app is successfully connected to my refrigerator but does not run.	<ul style="list-style-type: none">Exit and restart the SmartThings app or disconnect and reconnect the router.Unplug the power cord of the refrigerator, and then plug it in again after 1 minute.

Smart Grid

(applicable models only)

Symptom	Action
<p>What Do I Need to use the Energy Management and Smart Grid functions?</p>	<p>To use the Smart Grid (Demand Response) and Energy Management functions on your refrigerator, you need the following:</p> <p>Devices</p> <ul style="list-style-type: none"> • A wireless access point (router) • A Samsung Energy Management-supported refrigerator • A smartphone <p>Registration</p> <ul style="list-style-type: none"> • Connect your refrigerator to your home Wi-Fi network. • Register for the EMS service with your electric company. Your electric company must have an EMS (Energy Management System) supporting SEP (Smart Energy profile). <p>App</p> <ul style="list-style-type: none"> • Download the SmartThings app from the Google Play Store, Apple App Store, or Samsung Galaxy Apps. • Install and run the SmartThings app on your smartphone.
<p>Why isn't the Energy Management function working normally?</p>	<ul style="list-style-type: none"> • Make sure that your home router is operating normally with proper Internet service and connection. • Make sure that the refrigerator is connected to the AP (router). <p>Checkpoints</p> <ul style="list-style-type: none"> • Connect your smartphone to the router (AP, Access Point), and then check if you can browse the Internet on the smartphone.
<p>Why isn't the Delay Defrost Capability working normally?</p>	<ul style="list-style-type: none"> • Make sure that your home router is operating normally with proper Internet service and connection.

LIMITED WARRANTY (U.S.A.)

SAMSUNG REFRIGERATOR

LIMITED WARRANTY TO ORIGINAL CONSUMER PURCHASER WITH PROOF OF PURCHASE

This SAMSUNG brand product, as supplied and distributed by Samsung Electronics America, Inc. (SAMSUNG) and delivered new, in the original carton to the original consumer purchaser, is warranted by SAMSUNG against manufacturing defects in materials or workmanship for the limited warranty periods, starting on the date of delivery to the original consumer purchaser:

One (1) year parts and labor

Five (5) years parts and labor on Sealed Refrigeration System Only (Compressor, Evaporator, Condenser, Drier, and Connecting Tubing)

Ten (10) years part and Five (5) years labor on Digital Inverter Compressor Only

This limited warranty is valid only on products purchased and used in the United States that have been installed, operated, and maintained according to the instructions attached to or furnished with the product. To receive warranty service, the purchaser must contact SAMSUNG at the address or phone number provided below for problem determination and service procedures. Warranty service can only be performed by a SAMSUNG authorized service center. The original dated bill of sale and/or proof of delivery must be presented upon request as proof of purchase to SAMSUNG or SAMSUNG's authorized service center to receive warranty service.

SAMSUNG will provide in-home service within the contiguous United States during the warranty period at no charge, subject to availability of SAMSUNG authorized servicers within the customer's geographic area. If in-home service is not available, SAMSUNG may elect, at its option, to provide transportation of the product to and from an authorized service center. If the product is located in an area where service by a SAMSUNG authorized servicer is not available, you may be responsible for a trip charge or required to bring the product to a SAMSUNG authorized service center for service.

To receive in-home service, product must be unobstructed and accessible to the service agent.

During the applicable warranty period, a product will be repaired, replaced, or the purchase price refunded, at the sole option of SAMSUNG. SAMSUNG may use new or reconditioned parts in repairing a product, or replace the product with a new or reconditioned product. Replacement parts and products are warranted for the remaining portion of the original product's warranty or ninety (90) days, whichever is longer. All replaced parts and products are the property of SAMSUNG and you must return them to SAMSUNG.

This limited warranty covers manufacturing defects in materials or workmanship encountered in normal household, noncommercial use of this product and shall not cover the following: damage that occurs in shipment, delivery, installation, and uses for which this product was not intended; damage caused by unauthorized modification or alteration of the product; product where the original factory serial numbers have been removed, defaced, changed in any way, or cannot be readily determined; cosmetic damage including scratches, dents, chips, and other damage to the product's finishes; damage caused by abuse, misuse, pest infestations, accident, fire, floods, or other acts of nature or God; damage caused by use of equipment, utilities, services, parts, supplies, accessories, applications, installations, repairs, external wiring or connectors not supplied or authorized by SAMSUNG; damage caused by incorrect electrical line current, voltage, fluctuations and surges; damage caused by failure to operate and maintain the product according to instructions; in-home instruction on how to use your product; and service to correct installation not in accordance with electrical or plumbing codes or correction of household electrical or plumbing (i.e., house wiring, fuses, or water inlet hoses). The cost of repair or replacement under these excluded circumstances shall be the customer's responsibility.

Visits by an authorized servicer to explain product functions, maintenance or installation are not covered by this limited warranty. Please contact SAMSUNG at the number below for assistance with any of these issues.

EXCLUSION OF IMPLIED WARRANTIES

IMPLIED WARRANTIES, INCLUDING THE IMPLIED WARRANTIES OF MERCHANTABILITY OR FITNESS FOR A PARTICULAR PURPOSE, ARE LIMITED TO ONE YEAR OR THE SHORTEST PERIOD ALLOWED BY LAW. Some states do not allow limitations on how long an implied warranty lasts, so the above limitations or exclusions may not apply to you. This warranty gives you specific rights, and you may also have other rights, which vary from state to state.

LIMITED WARRANTY (U.S.A.)

LIMITATION OF REMEDIES

YOUR SOLE AND EXCLUSIVE REMEDY IS PRODUCT REPAIR, PRODUCT REPLACEMENT, OR REFUND OF THE PURCHASE PRICE AT SAMSUNG'S OPTION, AS PROVIDED IN THIS LIMITED WARRANTY. SAMSUNG SHALL NOT BE LIABLE FOR SPECIAL, INCIDENTAL OR CONSEQUENTIAL DAMAGES, INCLUDING BUT NOT LIMITED TO TIME AWAY FROM WORK, HOTELS AND/OR RESTAURANT MEALS, REMODELING EXPENSES, LOSS OF REVENUE OR PROFITS, FAILURE TO REALIZE SAVINGS OR OTHER BENEFITS REGARDLESS OF THE LEGAL THEORY ON WHICH THE CLAIM IS BASED, AND EVEN IF SAMSUNG HAS BEEN ADVISED OF THE POSSIBILITY OF SUCH DAMAGES. Some states do not allow exclusion or limitation of incidental or consequential damages, so the above limitations or exclusions may not apply to you. This warranty gives you specific rights, and you may also have other rights, which vary from state to state.

SAMSUNG does not warrant uninterrupted or error-free operation of the product. No warranty or guarantee given by any other person, firm, or corporation with respect to this product shall be binding on SAMSUNG.

To obtain warranty service, please contact SAMSUNG at:

Samsung Electronics America, Inc.
700 Sylvan Avenue,
Englewood Cliffs, NJ 07632
1-800-SAMSUNG (726-7864)
www.samsung.com/support

Warranty Information (CANADA)

If your refrigerator needs service

Do not hesitate to call any Samsung Authorized Service Center nearby giving them your name, address and telephone number if your product is not functioning properly.

Limited Warranty for Original Purchaser

This Samsung product is warranted by Samsung Electronics Canada Inc. (hereafter referred to as SECA) against manufacturing defects in material or workmanship for the following periods:

Labor: 1 year (in-home)

Parts: 1 year

Inverter Compressor: 10 years (Part only)

SECA further warrants that if this product fails to operate properly within the specified warranty period and the failure is due to improper workmanship or defective material, SECA will repair or replace the product at its option. In-home service is not available in all areas. Contact us to find out if in-home service is currently available in your area by using the contact information at the back of this warranty.

All warranty repairs or part replacements must be performed by a SECA Authorized Service Center. (To find the nearest SECA Service Center, call 1-800-SAMSUNG (7267864) or visit our web site at www.samsung.com/ca)

Obligation to the Original Owner

The original dated sales receipt must be retained by the customer and is the only acceptable proof of purchase. It must be presented to a SECA Authorized Service Center at the time service is requested before warranty services are rendered. On all carry-in models, transportation to and from the Authorized Service Center is the responsibility of the customer.

Warranty Information (CANADA)

Exclusions of the Warranty

This warranty does not cover damage due to accident, fire, flood, and/or other Acts of God, misuse, incorrect line voltage, improper installation, improper or unauthorized repairs, commercial use, or damage that occurs during shipping. Customer adjustments which are explained in this owners manual are not covered under the terms of this warranty. This warranty will automatically be voided for any unit found with a missing or altered serial number. This warranty is valid only on products purchased and used in Canada.

SAMSUNG CUSTOMER CARE CENTER

Samsung Electronics Canada Inc.
2050 Derry Road West
Mississauga, Ontario L5N 0B9
Canada
1-800-Samsung (726-7864)
www.samsung.com/support

NOTICE TO QUEBEC CONSUMERS – Warranty of Availability of Replacement Parts, Repair Services, and Maintenance and Repair Information

Replacement Parts

Although Samsung Canada will use reasonable efforts to make replacement parts available to customers (subject to availability and applicable lead times), Samsung Canada **does not guarantee** the availability of replacement parts within the meaning of the warranty of availability set out in sections 39 (paragraph 3), 39.1 and 39.2 of the Quebec Consumer Protection Act.

To purchase replacement parts and tools for self-repair, please visit:
samsung.com/ca/support/buy-certified-parts

Repair Services

Although Samsung Canada offers repair services for Samsung products through Samsung Authorized Service Centers located in most major urban centers (defined as a city in Canada with a population equal or greater than 50,000) across Canada, Samsung Canada **does not guarantee** the availability of any repair services within the meaning of the warranty of availability set out in sections 39 (paragraph 3), 39.1 and 39.2 of the Quebec Consumer Protection Act in all locations, cities, or regions in Quebec.

To find your nearest Samsung Authorized Service Center, please visit:
samsung.com/ca/support/service-center

Information for Maintenance or Repair

Although Samsung Canada provides information on the maintenance and/or repair of goods for select Samsung products (please visit samsung.com/ca/support/self-repair for more information), Samsung Canada **does not guarantee** the availability of information that is necessary to maintain or repair Samsung products within the meaning of the warranty of availability set out in sections 39 (paragraph 3), 39.1 and 39.2 of the Quebec Consumer Protection.

DISCLAIMER OF LIABILITY

Samsung is not liable for any damage or defect determined to be caused by repair by a non-authorized service provider, self-repair or non-professional repair of the product. Samsung is not liable for any resulting damage to the product, person, or property, or any injury or other product safety issue caused by or resulting from any repair, or any attempt to repair, any diagnosis, maintenance, or modification performed by any person, including, but not limited to, any of the following: (i) any indirect, incidental, special, or consequential damages (including but not limited to, damage to or loss of personal or commercial property, damage to reputation, loss of use, cost of purchase of replacement goods, etc.); (ii) any loss of data, goodwill, privacy, or profits or loss of business opportunity; and (iii) any inability to use, or reduced functionality of, the product. Any damage or defect to product resulting from a repair, or an attempt to repair, the product by any person (other than a Samsung certified service provider) will not be covered by the warranty. Samsung's liability shall be limited to the greatest extent permitted by law.

All text, graphics, user interfaces, visual interfaces, photographs, trademarks, and logos (collectively, "Content"), including but not limited to the design, structure, selection, coordination, "look and feel" and arrangement of such Content, contained in this manual is owned, controlled or licensed by or to Samsung, and is protected by trade dress, copyright, patent and trademark laws, and various other intellectual property rights and unfair competition laws.

No part of this manual or the Content may be copied, reproduced, republished, uploaded, posted, publicly displayed, encoded, translated, transmitted or distributed in any way (including "mirroring") to anyone, any entity, any other computer, server, Web site or other medium for publication or distribution or for any commercial purpose, without Samsung's express prior written consent.

Warranty Information (CANADA)

Limitation of Liability. WHILE SAMSUNG MAKES ALL REASONABLE EFFORTS TO ENSURE THAT ALL INFORMATION IN THIS MANUAL IS CORRECT, SAMSUNG DOES NOT ASSUME ANY RESPONSIBILITY FOR THE ACCURACY OR COMPLETENESS OF ANY INFORMATION CONTAINED IN THIS MANUAL. SAMSUNG PROVIDES INFORMATION AND MATERIALS CONTAINED IN THIS MANUAL TO YOU ON AN "AS IS" BASIS WITHOUT WARRANTY OF ANY KIND, EITHER EXPRESS OR IMPLIED. SAMSUNG SPECIFICALLY DISCLAIMS ANY LIABILITY FOR ANY DIRECT, INDIRECT, INCIDENTAL, CONSEQUENTIAL OR SPECIAL DAMAGES ARISING OUT OF OR IN ANY WAY CONNECTED WITH YOUR ACCESS TO OR USE OF THE INFORMATION IN THIS MANUAL, INCLUDING BUT NOT LIMITED TO ANY LOSS OR DAMAGE CAUSED BY YOUR RELIANCE ON INFORMATION OBTAINED THROUGH THIS MANUAL. Some jurisdictions do not allow exclusion of certain warranties or limitations of liability, so the above limitations or exclusions may not apply to you. Samsung's liability in any case shall be limited to the greatest extent permitted by law.

Samsung reserves the right, at its sole discretion, to change, modify, add or remove portions of any part of this manual at any time. It is your responsibility to check the manual periodically for changes. Your use of the manual will mean that you accept and agree to the terms and conditions set out in this manual. If you do not agree to comply with the terms and conditions of this manual, in whole or in part, please stop using this manual immediately.

Regulatory Notice

FCC Notice

FCC CAUTION:

Any changes or modifications not expressly approved by the party responsible for compliance could void the user's authority to operate the equipment.

This appliance contains the transmitter module.

This device complies with Part 15 of FCC Rules. Operation is Subject to the following two conditions:

- (1) This device may not cause harmful interference, and
- (2) This device must accept any interference received including interference that cause undesired operation.

For products available in the US and Canadian markets, only channels 1~11 are available. You cannot select other channels.

FCC STATEMENT:

This equipment has been tested and found to comply within the limits for a Class B digital device, pursuant to part 15 of the FCC Rules. These limits are designed to provide reasonable protection against harmful interference in a residential installation.

This equipment generates, uses, and can radiate radio frequency energy and, if not installed and used in accordance with the instructions, may cause harmful interference to radio communications. However, there is no guarantee that interference will not occur in a particular installation. If this equipment does cause harmful interference to radio or television reception, which can be determined by turning the equipment off and on, the user is encouraged to try to correct the interference by one or more of the following measures:

- Reorient or relocate the receiving antenna
- Increase the separation between the equipment and receiver
- Connect the equipment to an outlet that is on a different circuit than the receiver.
- Consult the dealer or an experienced radio/TV technician for help.

FCC RADIATION EXPOSURE STATEMENT:

This equipment complies with FCC radiation exposure limits set forth for an uncontrolled environment.

This equipment should be installed and operated so there is at least 8 inches (20 cm) between the radiator and your body. This device and it's antennas must not be co-located or operated in conjunction with any other antenna or transmitter except in accordance with FCC multi-transmitter product procedures.

Regulatory Notice

IC Notice

This appliance contains the transmitter module.

The term “IC” before the radio certification number only signifies that Industry Canada technical specifications were met. Operation is subject to the following two conditions : (1) this device may not cause interference, and (2) this device must accept any interference, including interference that may cause undesired operation of the device.

This Class B digital apparatus complies with Canadian ICES-003.

For products available in the US and Canadian markets, only channels 1~11 are available. You cannot select other channels.

IC RADIATION EXPOSURE STATEMENT:

This equipment complies with IC RSS-102 radiation exposure limits set forth for an uncontrolled environment. This equipment should be installed and operated so there is at least 8 inches (20 cm) between the radiator and your body. This device and it's antennas must not be co-located or operated in conjunction with any other antenna or transmitter except in accordance with FCC multi-transmitter product procedures.

SAVE THESE INSTRUCTIONS

Open Source Announcement

Open Source Announcement

The software included in this product contains open source software.

The following URL http://opensource.samsung.com/opensource/SMART_TP1_0/seq/0 leads to open source license information as related to this product.





Scan the QR code* or visit
www.samsung.com/spsn
to view our helpful
How-to Videos and Live Shows

* Requires reader to be installed on your
smartphone

Scan this with your smartphone

U.S.A - Consumer Electronics - Mobile Phones	1-800-SAMSUNG (726-7864) 1-844-SAM-PAYS (726-7297)	www.samsung.com/support
CANADA	1-800-Samsung (726-7864)	

