

# Vacuum-sealing drawer

GV451720



You can find additional information and explanations online.  
Scan the QR code on the title page.



# Table of contents

<b>1</b>	<b>IMPORTANT SAFETY INSTRUCTIONS</b>	<b>3</b>		
1.1	Safety definitions	3		
1.2	Safe use	3		
1.3	Child safety	3		
1.4	Proper installation and maintenance	4		
1.5	State of California Proposition 65 Warnings	4		
<b>2</b>	<b>Preventing material damage</b>	<b>5</b>		
<b>3</b>	<b>Environmental protection and energy-saving</b>	<b>5</b>		
3.1	Disposal of packaging	5		
<b>4</b>	<b>Before using for the first time</b>	<b>5</b>		
4.1	Cleaning the appliance before using it for the first time	5		
<b>5</b>	<b>Familiarizing yourself with your appliance</b>	<b>5</b>		
5.1	Function	5		
5.2	Appliance	6		
5.3	Control elements	6		
5.4	Vacuum-sealing levels	6		
<b>6</b>	<b>Accessories</b>	<b>6</b>		
6.1	Other accessories	7		
<b>7</b>	<b>Basic Operation</b>	<b>7</b>		
7.1	Opening the appliance	7		
7.2	Closing the appliance	7		
7.3	Switching on the appliance	7		
7.4	Switching off the appliance	7		
<b>8</b>	<b>Vacuum-sealing in a bag</b>	<b>7</b>		
8.1	Suitable vacuum-sealing bags	7		
8.2	Filling the bag	8		
8.3	Vacuum-sealing in a bag	8		
8.4	Early heat-sealing	9		
8.5	Canceling the vacuum-sealing process in a bag	9		
<b>9</b>	<b>Vacuum-sealing in a container</b>	<b>9</b>		
9.1	Suitable vacuum-sealing containers	9		
9.2	Vacuum-sealing in a container	10		
9.3	Canceling the vacuum-sealing process in a container	10		
<b>10</b>	<b>Drying</b>	<b>10</b>		
10.1	Starting drying	10		
<b>11</b>	<b>Cleaning and maintenance</b>	<b>10</b>		
11.1	Cleaning agents	10		
11.2	Cleaning the appliance	11		
11.3	Cleaning the glass front and glass lid	11		
11.4	Cleaning the stainless steel vacuum-sealing compartment	11		
11.5	Cleaning the plastic control panel	11		
11.6	Cleaning the heat-sealing bar	11		
11.7	Cleaning the accessories	11		
<b>12</b>	<b>Troubleshooting</b>	<b>11</b>		
12.1	Malfunctions	11		
12.2	Display information	12		
<b>13</b>	<b>How it works</b>	<b>13</b>		
13.1	Vacuum-sealing for sous-vide cooking	13		
13.2	Vacuum-sealing glass bottles	13		
13.3	Fast marinating and flavoring	13		
13.4	Storing and transporting food	14		
13.5	Recommended settings	14		
<b>14</b>	<b>Disposal</b>	<b>15</b>		
14.1	Disposal of your old appliance	15		
<b>15</b>	<b>Customer Service</b>	<b>15</b>		
15.1	Model number (E-Nr.) and production number (FD)	15		
15.2	Rating plate location	15		
<b>16</b>	<b>STATEMENT OF LIMITED PRODUCT WARRANTY</b>	<b>15</b>		
16.1	What this warranty covers & Who it applies to	15		
16.2	How long the warranty lasts	16		
16.3	Repair/replace as your exclusive remedy	16		
16.4	Out of warranty product	16		
16.5	Warranty exclusions	16		
16.6	Obtaining warranty service	17		
16.7	Product information	17		



# IMPORTANT SAFETY INSTRUCTIONS

## READ AND SAVE THESE INSTRUCTIONS

Read all of the instructions carefully before using the appliance. In order to reduce the risk of fire, electric shocks and personal injuries when using the appliance, follow the basic safety precautions, including the following safety instructions.

### 1.1 Safety definitions

Here you can find explanations of the safety signal words used in this manual.

#### **WARNING**

This indicates that death or serious injuries may occur as a result of non-observance of this warning.

#### **CAUTION**

This indicates that minor or moderate injuries may occur as a result of non-observance of this warning.

#### **NOTICE**

This indicates that damage to the appliance or property may occur as a result of non-compliance with this advisory.

**Note:** This alerts you to important information.

### 1.2 Safe use

#### **WARNING**

When properly cared for, your new appliance has been designed to be safe and reliable.

- ▶ Read all instructions carefully before use. These precautions will reduce the risk of burns, electric shock, fire, and injury to persons.
- ▶ When using kitchen appliances, basic safety precautions must be followed, including those in the following pages.

This appliance is intended for normal family household use only. It is not approved for outdoor use. See the Statement of Limited Product Warranty. If you have any questions, contact the manufacturer.

Examine the appliance after unpacking it. In the event of transport damage, do not plug it in.

#### **WARNING**

Using this appliance other than for its intended use can cause fire or injury to persons.

- ▶ Use this appliance only for its intended use as described in this manual.
- ▶ Never use the appliance for storage.

#### **WARNING**

The heat-sealing bar in the vacuum-sealing compartment becomes extremely hot if the appliance is used frequently and there are long heat-sealing times.

- ▶ Never touch the hot heat-sealing bar.
- ▶ Keep children away from the appliance.

#### **WARNING**

Moisture intrusion may cause an electric shock.

- ▶ Do not use any steam cleaners or high-pressure cleaners to clean the appliance.

To avoid risk of injury from damaged insulation of the power cord, observe the following.

- ▶ Never let the power cord come into contact with heat sources.
- ▶ Never let the power cord come into contact with sharp points or edges.
- ▶ Never kink, crush or modify the power cord.

#### **WARNING**

The heat-sealing bar in the vacuum-sealing compartment becomes extremely hot. Flammable vapors may ignite.

- ▶ Do not vacuum-seal any flammable liquids in the vacuum-sealing bag.
- ▶ Do not store any combustible materials and objects inside the appliance.

#### **WARNING**

The smallest cracks in the glass lid may result in it imploding when the vacuum is attached.

- ▶ Unplug the appliance from the mains or switch off the fuse in the fuse box.
- ▶ Call Customer Service.

Any misuse of the vacuum-sealing drawer may lead to injury.

- ▶ Do not insert any hoses that are connected to the appliance into any body cavities.
- ▶ Do not vacuum-seal any living animals.

#### **WARNING**

During the vacuuming process, the vacuum-sealing compartment and the glass lid deform due to the high negative pressure. The protective layer on the glass may be damaged and the glass lid may break.

- ▶ Screw-top jars, other hard containers, and non-deformable food that are vacuum-sealed in the compartment when the lid is closed must not come into contact with this lid.
- ▶ Hard containers and non-deformable food must not protrude over a maximum height of 3¼" (80 mm).

### 1.3 Child safety

This appliance is not intended for use by persons (including children) with reduced physical, sensory or mental capabilities, or lack of experience and knowledge, unless they have been given supervision or instruction concerning use of the appliance by a person responsible for their safety.

When children become old enough to use the appliance, it is the responsibility of the parents or legal guardians to ensure that they are instructed in safe practices by qualified persons. Children should be supervised to ensure that they do not play with the appliance.

#### **WARNING**

Do not allow children to use this appliance unless closely supervised by an adult.

- ▶ Children and pets should not be left alone or unattended in the area where the appliance is in use. They should never be allowed to play in its vicinity, whether or not the appliance is in use.



# IMPORTANT SAFETY INSTRUCTIONS

## READ AND SAVE THESE INSTRUCTIONS

Do not allow anyone to climb, stand, lean, sit, or hang on any part of an appliance, especially a door, warming drawer, or storage drawer.

- ▶ This can damage the appliance, and the unit may tip over, potentially causing severe injury.

Do not let children play with the appliance.

### CAUTION

Do not store items of interest to children in an appliance, in cabinets above an appliance or on the back-guard of an appliance.

Children climbing on the appliance to reach items could be seriously injured.

Do Not Leave Children Alone.

- ▶ Children should not be left alone or unattended in the area where the appliance is in use.
- ▶ They should never be allowed to sit or stand on any part of the appliance.

### WARNING

To avoid the risk of suffocation:

- ▶ Do not allow children to play with packaging material.

## 1.4 Proper installation and maintenance

### WARNING

In the event of a malfunction, it might become necessary to turn off the power supply.

- ▶ Have the installer show you the circuit breaker or fuse. Mark it for easy reference.

To avoid electrical shock hazard, before servicing the appliance, turn power off at the service panel and lock the panel to prevent the power from being switched on accidentally.

Proper Installation - Improper installation or grounding can cause electric shock.

- ▶ This appliance must be properly installed and grounded by a qualified technician.
- ▶ Connect only to properly grounded outlet.
- ▶ Refer to installation instructions for details.

User Servicing - Do not repair or replace any part of the appliance unless specifically recommended in this manual.

- ▶ All other servicing should be referred to an authorized service provider.

### WARNING

Malfunctions can cause injuries.

- ▶ Do not operate this appliance if it is not working properly, or if it has been damaged. Contact an authorized service provider.

## 1.5 State of California Proposition 65 Warnings

This product may contain a chemical known to the State of California, which can cause cancer or reproductive

harm. Therefore, the packaging of your product may bear the following label as required by California:

#### STATE OF CALIFORNIA PROPOSITION 65 WARNING:



**WARNING**

Cancer and Reproductive Harm - [www.P65Warnings.ca.gov](http://www.P65Warnings.ca.gov)

## 2 Preventing material damage

### NOTICE

Damage to the appliance may affect the safety considerably.

- ▶ Check the appliance for damage before each use.
- ▶ Check that the glass lid is intact.
- ▶ Never use a damaged appliance.
- ▶ Call Customer Service.

Using the appliance carelessly may cause damage to the appliance.

- ▶ Open and close the glass lid slowly.
- ▶ Do not place any objects on the glass lid.
- ▶ Do not use the appliance as a work surface or storage space.
- ▶ Do not let any objects fall onto the glass lid.
- ▶ Pull the drawer out completely during use.
- ▶ After use, close the drawer completely.

Foreign objects in the vacuum-sealing compartment damage the appliance.

- ▶ Before closing the glass lid, ensure that there is no debris in the vacuum-sealing compartment.

If the seal is positioned incorrectly or is damaged, this impairs the function of the appliance and may damage the appliance.

- ▶ Check that the seal is positioned correctly on the glass lid.
- ▶ The seal's contact surface must be clean and free from debris.

- ▶ Do not damage the seal with pointed or sharp objects.
- ▶ Never operate an appliance with a defective seal.
- ▶ If a seal is defective, contact customer service.

Using tools to open the glass lid damages the appliance.

- ▶ In the event of a power outage during the vacuum-sealing process, wait until the power supply is restored. The vacuum in the vacuum-sealing compartment is retained. Restart the vacuum-sealing process.

Escaping steam caused by boiling at excessive temperatures may lead to malfunctions.

- ▶ Only use bags that are suitable for vacuum-sealing food.
- ▶ Do not use any sales packages that have already been opened.
- ▶ Process the food that is to be vacuum-sealed at an output temperature of 33-46 °F (1-8 °C).
- ▶ Do not vacuum-seal liquids in the vacuum-sealing bag at the highest level. Recommendation: Use vacuum-sealing level 2.
- ▶ Heat-seal the bag if you notice an intensified formation of bubbles.

Moisture may damage the appliance.

- ▶ Do not use the appliance to store food and drinks. The moisture in the food may cause corrosion damage.

## 3 Environmental protection and energy-saving

### 3.1 Disposal of packaging

The packaging materials are environmentally compatible and can be recycled.

- ▶ Sort the individual components by type and dispose of them separately.

## 4 Before using for the first time

Prepare the appliance for use.

### 4.1 Cleaning the appliance before using it for the first time

**Note:** Once the mains plug is connected, a signal tone sounds. The indicators light up one after the other.

**Requirement:** There are no objects in the appliance.

1. Press on the appliance's front panel.
- ✓ The appliance opens and can be pulled out all the way by the sides or underside of the front panel.
2. Remove the raised vacuuming platform.
3. Clean the appliance with a damp cloth and a neutral cleaning agent, such as dishwashing liquid and water.

## 5 Familiarizing yourself with your appliance

### 5.1 Function

During the vacuum-sealing process, air is pumped out of the vacuum-sealing compartment and the bag. This produces a high vacuum in the compartment. The higher the vacuum-sealing level, the less air remains in the compartment and the bag, and the higher the pressure difference to the environment.

Once the selected vacuum-sealing level has been reached, the heat-sealing bar is pressed against the silicone bar on the glass lid. During this, the bag is heat-sealed.

After a short cooling time, air flows back into the compartment, creating a loud noise. During this process, the bag suddenly contracts and encloses the food. The drawer's glass lid then opens.

## 5.2 Appliance

Here you can find an overview of the parts of your appliance.

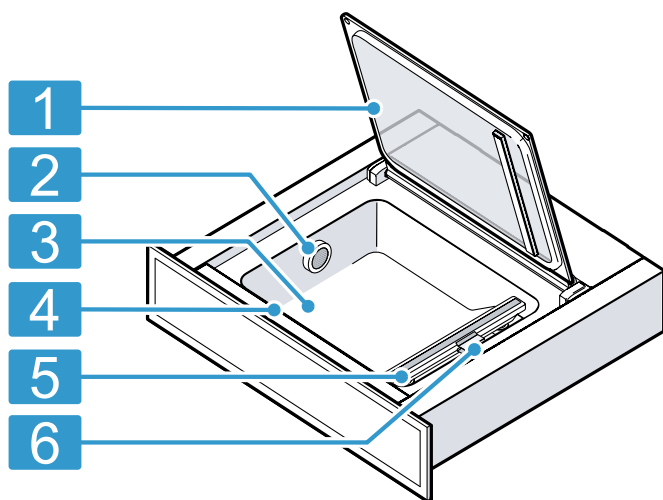

1	Glass lid
2	Air outlet
3	Vacuum-sealing compartment
4	Control panel
5	Heat-sealing bar
6	Bag clamp

## 5.3 Control elements

You can use the control panel to configure all functions of your appliance and to obtain information about the operating status.



Symbol	Meaning	Explanation
⏻	Switch on Switch off	Switching on the appliance Switching off the appliance
⬆	Vacuum-sealing level	Select the vacuum-sealing level
⏸	Heat-sealing time	Select a heat-sealing time Heat-seal the vacuum-sealing bag early
▶	Start	Start the vacuum-sealing process
■	Stop	Cancel the vacuum-sealing process
🌀	Dry	Dry the pump
⚠	Note	Refer to the fault table

## 5.4 Vacuum-sealing levels





The vacuum-sealing levels 1 to 3 achieve different degrees of vacuum. When vacuum-sealing in the container, the degrees of vacuum are lower and therefore better suited for the particular food. When the external vacuum adapter is at-

tached, the appliance automatically detects which mode has just been activated.

Vacuum-sealing levels Display	1	2	3
	●	●●	●●●
Vacuum-sealing in a bag	80 %	95 %	99 %
Vacuum-sealing containers and bottles	50 %	75 %	90 %

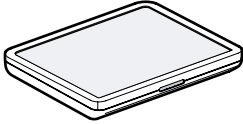
# 6 Accessories

Only use genuine accessories. These are designed especially for your appliance.

Accessories	Property	Use
Raised vacuuming platform		As a surface for flat food that is to be vacuum-sealed in the compartment.
External vacuum adapter		Vacuum-sealing containers or bottles.
Vacuum stoppers for bottles		Vacuum-seal and seal bottles.
Adapter for bottle stoppers		Connect vacuum stoppers for bottles to the vacuum hose.
Vacuum hose		Connect the external vacuum adapter to the vacuum-sealing container or the adapter for bottle stoppers.
Vacuum-sealing bags	7.1" x 11" (180 x 280 mm) - 50 pcs 9.5" x 13.8" (240 x 350 mm) - 50 pcs	

### 6.1 Other accessories

You can purchase other accessories from our Customer Service, specialist retailers or online.

You will find a comprehensive range of products for your appliance in our brochures and online:

[www.gaggenau.com](http://www.gaggenau.com)

Accessories are appliance-specific. When purchasing, always check for compatibility with your appliance model number (E-Nr).

You can find out which accessories are available for your appliance in our online shop or from our Customer Service.

Other accessories	Customer Service order number
Vacuum-sealing bag 7.1" x 11" (180 x 280 mm) (100 pcs)	00578813
Vacuum-sealing bag 9.5" x 13.8" (240 x 350 mm) (100 pcs)	00578814

## 7 Basic Operation

### 7.1 Opening the appliance

- ▶ Press on the appliance's front panel.
- ✓ The appliance opens and can be pulled out all the way by the sides or underside of the front panel.

### 7.2 Closing the appliance

- ▶ Push the appliance in.

### 7.3 Switching on the appliance

- ▶ Press .

### 7.4 Switching off the appliance

If you do not perform any actions on the appliance for 10 minutes, the appliance automatically switches off.

- ▶ Press .

## 8 Vacuum-sealing in a bag

In the bag, vacuum-sealed food has a longer shelf life. You can therefore marinate the food or prepare for sous-vide cooking.

### 8.1 Suitable vacuum-sealing bags

Use suitable vacuum-sealing bags in order to achieve an optimum result.

Use the original vacuum-sealing bags that are enclosed with the appliance or can be ordered as accessories.

- These bags are suitable for a temperature range of -40°F to 212°F (-40 °C to 100 °C).
- The optimum heat-sealing time for these bags is level 2.
- The bags are suitable for use in the microwave. Pierce the bags before you heat them up in the microwave.

Only use bags that are suitable for vacuum-sealing food.

Commercially available products are different when it comes to the quality of the food, temperature resistance, material, and surface.

The heat-sealing time for the vacuum-sealing bag always depends on the material from which it is made.

- Thin-walled bag: Heat-sealing level 1
- Thicker material: Heat-sealing level 2 or higher

Use bags with a maximum width of 240 mm.

The length of the heat-sealing bar limits the size of the vacuum-sealing bag that can be used.

## 8.2 Filling the bag

### Requirements

- The edge of the bag is clean and dry.
  - There is no food residue around the edge of the bag in the area around the seam.
1. Fold over the edge of the bag outwards by approx. 3 cm.



2. Where possible, position the items of food in the vacuum-sealing bag next to each other.

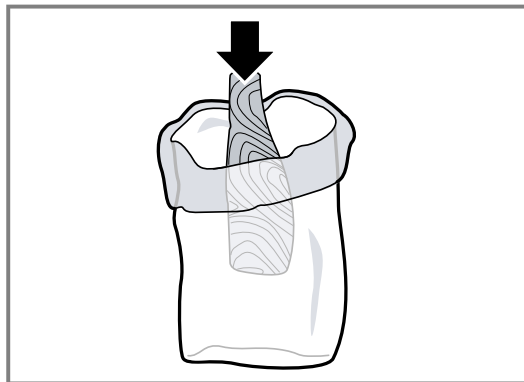

3. Fold the edge of the bag back.



**Tip:** To ensure that you can keep track of your bags and the food that is vacuum-sealed within them, make a note on the bag of the date of the vacuum-sealing along with the contents.

## 8.3 Vacuum-sealing in a bag

### ⚠ WARNING

The heat-sealing bar in the vacuum-sealing compartment becomes extremely hot if the appliance is used frequently and there are long heat-sealing times.

- ▶ Never touch the hot heat-sealing bar.
- ▶ Keep children away from the appliance.

**Requirement:** The initial temperature of the food is ideally in the range of 1–8 °C.

1. Open the glass lid.
2. Place the vacuum-sealing bag in the compartment and secure using the bag clamp.
3. Make sure that the air outlet is not covered so that the pump can extract the air from the compartment.
4. Ensure that the bag is centered and the ends of the bag are lying flat on top of each other on the heat-

sealing bar. To ensure that the heat-sealing seam is perfectly closed, secure the bag using the bag clamp.

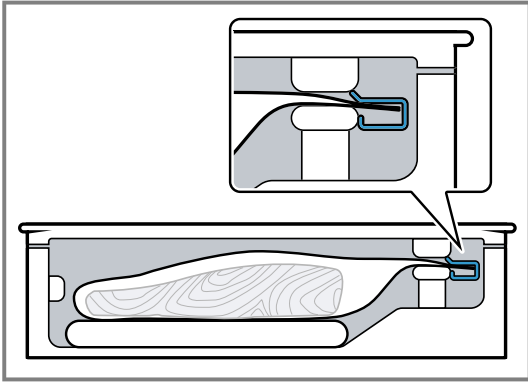

5. Use the raised vacuuming platform so that the bag does not slip.

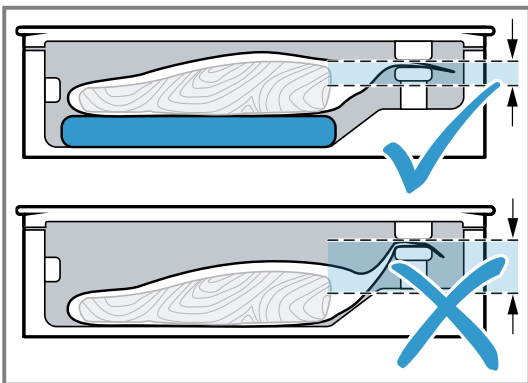

6. Press  $\uparrow$  to select the vacuum-sealing level.
7. Press  $\square$  to select the heat-sealing time.
8. Tightly close the glass lid and hold it there for a few seconds.
9. Press  $\blacktriangleright$  to start the vacuum-sealing process.
  - ✓ The vacuum-sealing process starts. The vacuum-sealing level indicators pulsate in orange one after the other until the selected value has been reached.
  - ✓ The heat-sealing process starts. The vacuum-sealing level indicators pulsate in orange one after the other until the selected level has been reached.
  - ✓ The vacuum-sealing process can take up to 1 minute.
  - ✓ At the end of the process, the compartment is ventilated. A signal tone sounds.
10. Once the vacuum-sealing process is finished, open the glass lid.

11. Remove the heat-sealed vacuum-sealing bag from the compartment.
12. After vacuum-sealing, check the heat-sealing seam on the bag.
  - ▶ Carefully pull the seam apart.
  - ▶ If the seam does not stay together, select a higher heat-sealing level.
  - ▶ If the seam is deformed, select a lower heat-sealing level or leave the appliance to cool down.

**Note:** If you vacuum-seal food in bags several times in succession, the heat-sealing bar becomes increasingly hotter. This may impair the quality of the heat-sealing seam. After several vacuum-sealing processes, select a lower heat-sealing time or leave the appliance to cool for approx. 2 minutes between the processes.

## 8.4 Early heat-sealing

Use this function if you only want to pack your delicate food in a bag so that it is air-tight, without the contents sitting too tightly against the bag. Also use this function if bubbles are forming in the liquids in the bag.

1. To stop the vacuum-sealing process and heat-seal the bag early, press  $\square$ .
  - ✓ The appliance displays the vacuum-sealing level until it is reached.
  - ✓ At the end of the process, the compartment is ventilated.
  - ✓ A signal tone sounds.
2. Open the glass lid.
3. Remove the heat-sealed vacuum-sealing bag from the compartment.

**Note:** To heat-seal the bag, the appliance requires a specific degree of vacuum. If you press  $\square$  first, the appliance pumps air out of the compartment until this degree has been reached. The bag is then heat-sealed.

## 8.5 Canceling the vacuum-sealing process in a bag

1. To cancel the vacuum-sealing process early, press  $\blacksquare$ .
  - ✓ The appliance displays the vacuum-sealing level until it is reached.
  - ✓ The bag is not heat-sealed.
  - ✓ The lid opens slightly and the compartment is ventilated.
  - ✓ A signal tone sounds.
2. Remove the vacuum-sealing bag from the compartment.

# 9 Vacuum-sealing in a container

In the container, vacuum-sealed food has a longer shelf life.

## 9.1 Suitable vacuum-sealing containers

Use suitable vacuum-sealing containers in order to achieve an optimal result.

Only use containers that are suitable for vacuum-sealing food.

Commercially available products are different when it comes to the quality of the food and material.

The vacuum hose attached to this appliance has an internal diameter of 3 mm.

You may need an adapter for your container so that the hose fits. These adapters are often already included with the vacuum-sealing containers.

## 9.2 Vacuum-sealing in a container

Vacuum-seal the food in a suitable vacuum-sealing container in order to preserve the food for longer.

1. Open the glass lid.
2. Plug the vacuum adapter into the air outlet.
3. Secure the hose to the vacuum adapter and the vacuum-sealing container.

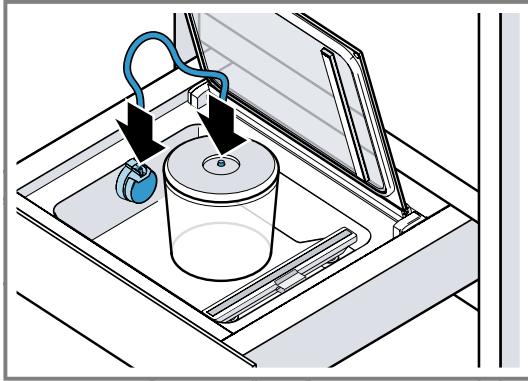

4. Press  $\uparrow$  to select the vacuum-sealing level.
5. Press  $\blacktriangleright$  to start the vacuum-sealing process.
  - ✓ The vacuum-sealing process starts. The vacuum-sealing level indicators pulsate in orange one after the other until the selected value has been reached.
  - ✓ The vacuum-sealing process can take up to 1 minute.
  - ✓ The vacuum-sealing level that has been reached lights up and a signal tone sounds.
6. Detach the hose from the container and the external vacuum adapter.

**Note:** If larger bubbles form, cancel the vacuum-sealing process. → Page 9

## 9.3 Canceling the vacuum-sealing process in a container

1. To cancel the vacuum-sealing process early, press  $\blacksquare$ .
  - ✓ The appliance displays the vacuum-sealing level until it is reached.
2. Detach the hose from the container and the external vacuum adapter.

# 10 Drying

When vacuum-sealing food, the smallest amount of water gets into the vacuum pump system.

This effect occurs predominantly when you are vacuum-sealing liquids or extremely moist food. For this reason, the appliance comes with a drying function, which further removes any liquid that collects in the pump. After a certain operating time, the appliance prompts you to run a drying cycle.

- If the  $\swarrow$  symbol lights up white, it is advisable to run a drying cycle. However, at this point, you can continue to use the appliance as normal.
- If the  $\swarrow$  symbol lights up red, you must run a drying cycle. The appliance blocks the vacuum-sealing function.

**Note:** We recommend that you run the drying cycle before the appliance blocks the vacuum-sealing function from working.

## 10.1 Starting drying

**Note:** You can close the appliance while drying is in progress.

**Requirement:**  $\swarrow$  lights up white or red.

1. Ensure that there are no objects or liquid residues in the vacuum-sealing compartment.
  - ▶ Clean the vacuum-sealing compartment if required.
2. Tightly close the glass lid and hold it there.
3. Press  $\swarrow$ .
  - To interrupt the drying cycle, press  $\blacksquare$ .  $\swarrow$  continues to light up white or red. Restart the drying cycle after switching the appliance back on.
  - ✓ The drying cycle starts and takes up to 20 minutes.
  - ✓ During the procedure,  $\swarrow$  pulsates in orange.
  - ✓ At the end of the process, the vacuum-sealing compartment is ventilated, and 3 short signal tones sound.
  - ✓ You can now open the glass lid.
  - ✓ If  $\odot$  no longer lights up, the appliance has cooled down and is ready for operation.
  - ✓ If, at the end of the drying cycle, a long signal tone sounds and  $\swarrow$  and  $\odot$  light up, there is still residual moisture in the pump system. Re-run the drying cycle once the appliance has cooled down.
  - ✓ If  $\swarrow$  continues to light up white or red, re-run the drying cycle.
4. Before restarting the appliance and after running the drying cycle, allow the appliance to cool down.

# 11 Cleaning and maintenance

**Note:** The Statement of Limited Product Warranty covers defects in materials and workmanship. Cleaning and maintenance is not covered by the warranty and a charge will apply. See the Statement of Limited Product Warranty for more details.

## 11.1 Cleaning agents

You can obtain suitable cleaning products from Customer Service or the online shop.

### NOTICE

Unsuitable cleaning agents may damage the surfaces of the appliance.

- ▶ Do not use strong or abrasive cleaning agents.
- ▶ Do not use cleaning agents with a high alcohol content.
- ▶ Do not use hard scouring pads or cleaning sponges.
- ▶ Only use glass cleaners, glass scrapers or stainless steel care products if recommended in the cleaning instructions for the relevant part.
- ▶ Wash sponge cloths thoroughly before use.

## 11.2 Cleaning the appliance

### WARNING

The heat-sealing bar in the vacuum-sealing compartment becomes extremely hot if the appliance is used frequently and there are long heat-sealing times.

- ▶ Never touch the hot heat-sealing bar.
- ▶ Keep children away from the appliance.

### WARNING

Moisture intrusion may cause an electric shock.

- ▶ Do not use any steam cleaners or high-pressure cleaners to clean the appliance.

### Requirements

- The appliance is switched off.
  - Ensure that the heat-sealing bar in the vacuum-sealing compartment has cooled down.
1. Clean the appliance with a damp cloth and neutral cleaning agents, such as dish soap and water. During cleaning, ensure that no water or other liquid gets into the vacuum-sealing compartment or, in particular, into the vacuum pump's air outlet. Never spray the inside or outside of the appliance with water.
  2. Leave the appliance and accessory parts to fully dry after they have been cleaned.

## 11.3 Cleaning the glass front and glass lid

- ▶ Clean the glass front and the glass lid with glass cleaner and a soft cloth. Do not use any abrasive sponges that may scratch or any glass scrapers.

## 11.4 Cleaning the stainless steel vacuum-sealing compartment

1. Always remove limescale, grease, starch or albumin stains immediately. Corrosion may form under such stains.
2. Clean with water and some dish soap.
3. Dry with a soft cloth.

## 11.5 Cleaning the plastic control panel

- ▶ Clean the control panel using a soft cloth. Do not use any abrasive sponges that may scratch or any glass scrapers.

## 11.6 Cleaning the heat-sealing bar

### NOTICE

Cleaning in the dishwasher leads to damage.

- ▶ Never clean the appliance components in the dishwasher.
1. Remove the remaining film from the heat-sealing bar.
  2. Never use abrasive cleaning agents to clean the heat-sealing bar.
  3. Dry with a soft cloth.

## 11.7 Cleaning the accessories

### NOTICE

Cleaning in the dishwasher leads to damage.

- ▶ Never clean the appliance components in the dishwasher.
1. Clean using a sponge cloth and hot soapy water in the direction of the finish.
  2. Dry with a soft cloth.

# 12 Troubleshooting

You can eliminate minor issues on your appliance yourself. Please read the information on eliminating issues before contacting Customer Service. This may avoid unnecessary repair visits.

### WARNING

To avoid risk of injury from improper repairs, observe the following.

- ▶ Only qualified technicians or authorized service providers should perform repairs.
- ▶ If the power cord or the appliance power cable of this appliance becomes damaged, it must be replaced with a special power cord or special appliance power cable, which is available from the manufacturer or the manufacturer's Customer Service.
- ▶ If the power cord of this appliance is damaged, it must be replaced by trained, specialist personnel.
- ▶ Only genuine spare parts may be used to repair the appliance.
- ▶ If the appliance has an issue, call Customer Service.

## 12.1 Malfunctions

Fault	Cause and troubleshooting
The appliance is not working.	The circuit breaker in the circuit breaker panel has tripped. ▶ Check the breaker panel.
The fuse in the fuse box has blown.	The circuit breaker in the circuit breaker panel has tripped. ▶ Call . → "Customer Service", Page 15
The front panel is not aligned.	The front panel was not aligned during installation. ▶ Adjust the front panel.

Fault	Cause and troubleshooting
The vacuum-sealing process will not start. ► does not appear even though the lid is closed.	The door switch on the glass lid is missing or is not being detected by the appliance. ► Call . → "Customer Service", Page 15
If you try to operate the appliance several times in succession, the vacuum-sealing process seems to run as normal but the bag is not heat-sealed.	The temperature protection switch for the heat-sealing transformer has tripped. 1. Allow the appliance to cool for at least 10 minutes. 2. Allow the appliance to cool for at least 2 minutes between vacuum-sealing operations. 3. Restart the vacuum-sealing process.
The bag is defective, which means that no vacuum remains in the vacuum-sealing bag.	Sharp parts of the food (such as bones) may poke holes in the bag. 1. Check the bag for damage. 2. Use a different bag if it is damaged. 3. Place sharp-edged food that is to be vacuum-sealed in the bag in such a way that you do not damage the wall of the bag.
The heat-sealing seam is defective, which means that no vacuum remains in the vacuum-sealing bag.	The selected heat-sealing time is unsuitable for the film jacket. ► Select a different heat-sealing time. There is liquid, grease or crumbs or creases along the heat-sealed seam. 1. Make sure that the bag is dry, that it has no creases, and that it is positioned fully on the heat-sealing bar. 2. Use a different bag if it is damaged. 3. Fold over the edge of the bag by 3 cm before you fill it.
The lid cannot be opened.	A slight vacuum has formed and it is holding the lid closed. 1. Never use force to open the lid. 2. Start a new vacuum-sealing process and then cancel it immediately. 3. Disconnect the appliance from the power supply. 4. Start up the appliance again after 30 seconds. 5. Press and hold ◻ for more than 5 seconds. ✓ The appliance is reset.

## 12.2 Display information

Fault	Cause and troubleshooting
Ⓢ appears after a few seconds.	<p>The glass lid has not been closed properly.</p> <ol style="list-style-type: none"> <li>1. Open and close the glass lid again.</li> <li>2. When doing so, lightly press on the glass lid for the first few seconds.</li> </ol> <hr/> <p>The seal on the glass lid is not fitted properly.</p> <p>► Check the seal.</p> <hr/> <p>The seal on the glass lid has deformed.</p> <p>► Gently press the seal to straighten it out.</p> <hr/> <p>The lid on the external vacuum-sealing container has not been closed properly.</p> <ol style="list-style-type: none"> <li>1. Check the position of the external vacuum adapter.</li> <li>2. Only use suitable vacuum-sealing containers.</li> </ol> <hr/> <p>The external vacuum adapter is not positioned correctly on the vacuum-sealing compartment's air outlet.</p> <p>► Check the position of the external vacuum adapter.</p>
Ⓢ appears after the pump has been running for 2 minutes.	As the temperature rises, liquids begin to boil, meaning that the vacuum cannot be formed. 1. Only vacuum-seal cold liquids. 2. If the vacuum-sealing compartment is wet, wipe it dry. 3. Heat-seal the vacuum-sealing bag early if larger bubbles form. 4. Select a lower vacuum-sealing level.
☞ and Ⓢ light up after the drying process.	One drying cycle alone was not sufficient. 1. Wait until Ⓢ goes out. 2. Repeat the drying process. → "Starting drying", Page 10

## 13 How it works

Here, you can find the ideal settings for various dishes as well as the best accessories and cookware. We have perfectly tailored these recommendations to your appliance.

### 13.1 Vacuum-sealing for sous-vide cooking

You can use your appliance to prepare food for sous-vide cooking. Sous-vide cooking is a method of cooking "under a vacuum" at low temperatures between 122-203°F (50–95 °C) and in 100% steam or in a bain marie.

The appliance is used to heat-seal the food in a special air-tight, heat-resistant cooking bag.

#### **⚠ WARNING**

Sous-vide cooking is a low-temperature cooking method; if the instructions for use and hygiene instructions are not adhered to, this can result adverse health effects.

- ▶ Only use high-quality, perfectly fresh food.
- ▶ Wash and disinfect your hands.
- ▶ Use disposable gloves, cooking tongs or grill tongs.
- ▶ Take extra care when preparing critical food, such as poultry, eggs, and fish.
- ▶ Always thoroughly rinse and peel fruit and vegetables.
- ▶ Always keep work surfaces and chopping boards clean.
- ▶ Use different cutting boards for different types of food.
- ▶ Only interrupt the cold chain briefly to prepare the food.
- ▶ Store vacuum-sealed food in the refrigerator for a maximum of 24 hours before you start the cooking process.
- ▶ Once the food is cooked, consume it immediately. Do not store it after cooking – not even in the refrigerator. It is not suitable for reheating.

#### **Notes**

- Use the enclosed vacuum-sealing bags for sous-vide cooking. You can reorder the vacuum-sealing bags.
- Do not cook the food in the bag in which you bought it (e.g. portions of fish). These bags are not suitable for sous-vide cooking.
- Position the items of food in the bag next to each other and not on top of each other.

### Vacuum-sealing for sous-vide cooking

1. In order to achieve an even transfer of heat and therefore a perfect cooking result, use the highest vacuum-sealing level to vacuum-seal food.
2. Before cooking the food, check that the vacuum in the bag is intact. To do this, refer to these points:
  - There is no air in the vacuum-sealing bag.
  - The heat-sealed seam is perfectly sealed.
  - There are no holes in the vacuum-sealing bag. Do not use a core temperature probe.
  - Pieces of meat or fish that have been vacuum-sealed together are not pressed directly against one another.
  - Vegetables and desserts are vacuum-sealed flat.

3. If the vacuum-sealing bag is not filled as it should be, place the food into a new bag and vacuum-seal it again.

**Note:** To prevent gases escaping from the food, e.g. from vegetables, vacuum-seal the food no more than one day before you cook it. The gases inhibit the transfer of heat or cause the texture of the food to change, thus altering how it cooks, as a result of the vacuum pressure.

### 13.2 Vacuum-sealing glass bottles

You can also use your appliance to vacuum and reseal glass bottles, e.g. bottles of cooking oil.

1. Fit the air outlet on the vacuum adapter in such a way that the outlet for the hose is facing upwards vertically.
2. Secure the vacuum stopper for bottles to the bottle opening.
3. Press the bottle stopper adapter onto the vacuum stopper for bottles.
4. Disconnect the hose from the vacuum adapter and secure the bottle stopper adapter.

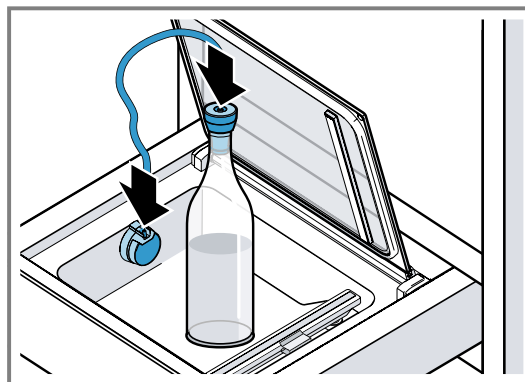

5. Press  $\uparrow$  to select the vacuum-sealing level.
  - ▶ Always vacuum-seal bottles at the lowest level.
  - ▶ Do not vacuum-seal any carbonated liquids, such as sparkling wine.
6. Press  $\blacktriangleright$  to start the vacuum-sealing process.
  - ✓ The vacuum-sealing process starts. The vacuum-sealing level indicators pulsate in orange one after the other until the selected value has been reached.
  - ✓ The vacuum-sealing level that has been reached lights up and a signal tone sounds.
7. Detach the hose from the bottle stopper adapter and the external vacuum adapter.
8. Undo the bottle stopper adapter from the vacuum stopper for bottles.

### 13.3 Fast marinating and flavoring

You can use your appliance to quickly add flavor to or marinate food such as meat, fruit, and vegetables. Marinating your food in the traditional way usually takes a long time and is not particularly intensive. When you vacuum-seal in a bag, the food's cell pores open. The marinade that is added can be absorbed quickly. This produces a more intensive taste in a much shorter time.

### 13.4 Storing and transporting food

You can use the vacuum-sealing process to store your food for longer and can benefit from additional advantages.

- Thanks to the low-oxygen environment in the vacuum, freshly vacuum-sealed food remains edible for longer when it is stored correctly.
- Freezer burn is less likely to occur when the food has been frozen and vacuum-sealed.
- You can re-seal food, such as jams and sauces, in glass containers.
- Vacuum-sealing significantly increases the storage time.
- Store food such as cheese, fish, or garlic without any unpleasant odors. The hermetic sealing that takes place during vacuum-sealing means that no unwanted odors can get out and the flavor cannot be absorbed by the other food.
- Sealed vacuum-sealing bags or vacuum-sealing containers are the ideal means of transport for liquid foods. They are easy to handle, leak-proof, and space-saving.

#### NOTICE

Glass containers that are too tall may damage the appliance's glass lid.

- ▶ Do not use glass containers that are taller than 80 cm.

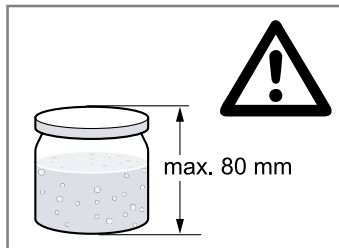

#### Notes

- Only use screw-top jars that are stable and intact.
- Only tighten the container by hand. The container is automatically sealed by the vacuum-sealing process.
- Not all jars or lids are suitable for being re-sealed under a vacuum. After vacuum-sealing, check whether a vacuum has been formed. A lid that is curving inwards and can only be opened with a lot of force is an indication that the vacuuming process has worked. If the lid makes a clicking sound when it is pushed in and released and if it is easy to open, no vacuum has occurred. Repeat the vacuum-sealing process or use more suitable screw-top jars.

### 13.5 Recommended settings

This section provides you with recommendations for the vacuum-sealing levels for different foods. Observe the specific information on the recommended vacuum-sealing levels as well as on preparing the food.

When stored correctly, vacuum-sealed food stays fresh for significantly longer. Higher vacuum-sealing levels retain the quality, appearance, and ingredients of the food.

#### Notes

- Only use fresh food.
- Check the quality of the food before vacuum-sealing it.
- Only vacuum-seal cold food – within a temperature range of 33-46°F (1–8°C) is best.
- Start at the lowest of the recommended vacuum-sealing levels.
- Check the quality of the food after you remove it from storage. Do not use any food that is of questionable quality.

#### Food at room temperature (68 to 73 °F / 20 to 23 °C)

Food	Vacuum-sealing level	recommendation
Baked items	1, 2, 3	
Dried baked items and cookies	1	
Tea and coffee	1, 2, 3	Store in a dark place
Rice and pasta	2	Vacuum-seal in a container
Flour and semolina	1	
Nuts without shell	3	Store in a dark place
Dried fruits	3	
Crackers and chips	1, 2	Vacuum-seal in a container

#### Fresh food that has been frozen (-0.5 to 3 °F / -18 to -16 °C) or stored in a refrigerator (37 to 44 °F / 3 to 7 °C)

Food	Vacuum-sealing level	recommendation
Fish	3	
Poultry	3	
Meat	3	
Whole sausage	3	
Sliced sausage	3	

Food	Vacuum-sealing level	recommendation
Hard cheese	3	
Soft cheese	2	Vacuum-seal in a container
Vegetables	2	Peel and blanch beforehand
Washed salad greens	2	Vacuum-seal in a container
Herbs	1, 2	Vacuum-seal in a container
Fruit, hard	3	
Fruit, soft	2	Vacuum-seal in a container Pre-frosting recommended

## 14 Disposal

### 14.1 Disposal of your old appliance

Environmentally compatible disposal allows valuable raw materials to be recycled.

1. Unplug the appliance from the power supply.

2. Cut through the power cord.

3. Dispose of the appliance in an environmentally responsible manner.

Information about current disposal methods can be obtained from your specialist dealer or local authority.

## 15 Customer Service

With any warranty repair, we will make sure your appliance is repaired by an authorized service provider using genuine replacement parts. We use only genuine replacement parts for all repairs.

You can obtain function-relevant and storable genuine spare parts from our Customer Service for up to 15 years from the date on which your appliance was placed on the market.

For more information, please contact our Customer Service team.

Detailed information on the warranty period and terms of warranty can be found in the Statement of Limited Product Warranty, from your retailer, or on our website.

USA:

1-877-442-4436

[www.gaggenau.com](http://www.gaggenau.com)

[www.gaggenau.com/us/appliances/eshop](http://www.gaggenau.com/us/appliances/eshop)

CA:

1-877-442-4436

[www.gaggenau.com](http://www.gaggenau.com)

[www.gaggenau.ca](http://www.gaggenau.ca)

### 15.1 Model number (E-Nr.) and production number (FD)

You can find the model number (E-Nr.) and the production number (FD) on the appliance's rating plate.

Making a note of your appliance's details and the Customer Service telephone number will enable you to find them again quickly.

### 15.2 Rating plate location

You can find the rating plate at the right side of the drawer. Open the drawer to view it.

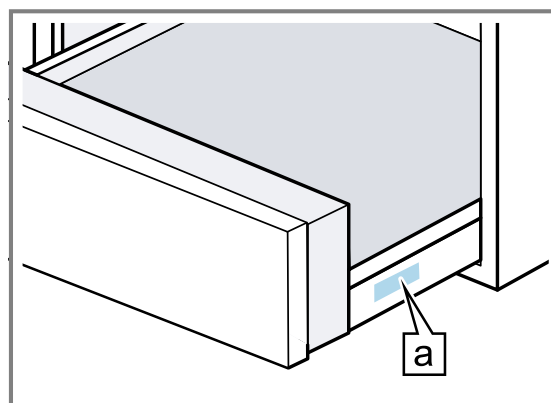

**a** Rating plate

## 16 STATEMENT OF LIMITED PRODUCT WARRANTY

### 16.1 What this warranty covers & Who it applies to

The limited warranty provided by BSH Home Appliances ("Gaggenau") in this Statement of Limited Product Warranty applies only to the Gaggenau appliance sold to

you ("Product"), provided that the Product was purchased on or after January 1, 2025:

- For your normal, household (non-commercial) use, and has in fact at all times only been used for normal household purposes.

- New at retail from a BSH authorized dealer or directly from BSH (not a display, "as is", or previously returned model), and not for resale, or commercial use.
- Within the United States or Canada, and has at all times remained within the country of original purchase.

The warranties stated herein apply to the original purchaser of the product warranted herein and to each succeeding owner of the product purchased for ordinary home use during the term of the warranty. Please make sure to register your Product; while not necessary to effectuate warranty coverage, it is the best way for Gaggenau to notify you in the unlikely event of a safety notice or product recall.

## 16.2 How long the warranty lasts

Gaggenau warrants that the Product is free from defects in materials and workmanship for a period of five (5) years from the date of the original delivery. The warranty shall only be extended for the time that elapsed between the date of your warranty claim and the date of the completed repair or replacement. This Product is also warranted to be free from **cosmetic** defects in material and workmanship (such as scratches of stainless steel, paint/porcelain blemishes, chips, dents, or other damage to the finish) of the Product, for a period of sixty (60) days from the date of delivery or closing date for new construction. This **cosmetic** warranty excludes slight color variations due to inherent differences in painted and porcelain parts, as well as differences caused by kitchen lighting, product location, or other similar factors. This **cosmetic** warranty specifically excludes any display, floor, "As Is", or "B" stock appliances.

## 16.3 Repair/replace as your exclusive remedy

During this warranty period, Gaggenau or one of its authorized service providers will repair your Product without charge to you (subject to certain limitations stated herein) if your Product proves to have been manufactured with a defect in materials or workmanship. If reasonable attempts to repair the Product have been made without success, then Gaggenau will replace your Product (upgraded models may be available to you, in Gaggenau's sole discretion, for an additional charge). Nothing in this warranty requires damaged or defective parts to be replaced with parts of a different type or design than the original parts. All removed parts and components shall become the property of Gaggenau at its sole option. All replaced and/or repaired parts shall assume the identity of the original part for purposes of this warranty and this warranty shall not be extended with respect to such parts. Gaggenau's sole liability and responsibility hereunder is to repair manufacturer-defective Product only, using a Gaggenau authorized service provider during normal business hours. For safety and property damage concerns, Gaggenau highly recommends that you do not attempt to repair the Product yourself, or use a non-authorized service provider; Gaggenau will have no responsibility or liability for damage resulting from repairs or work performed by a non-authorized service provider. Authorized service

providers are those persons or companies that have been specially trained on Gaggenau products, and who possess, in Gaggenau's opinion, a superior reputation for customer service and technical ability (note that they are independent entities and are not agents, partners, affiliates or representatives of Gaggenau). Nevertheless, taking your product to be serviced by a repair shop that is not affiliated with or an authorized dealer of Gaggenau will not void this warranty. Also, using third-party parts will not void this warranty. Notwithstanding the foregoing, Gaggenau will not incur any liability, or have responsibility, for the Product if it is located in a remote area (more than 100 miles from an authorized service provider) or is reasonably inaccessible, hazardous, threatening, or treacherous locale, surroundings, or environment; in any such event, if you request, Gaggenau would still pay for labor and parts and ship the parts to the nearest authorized service provider, but you would still be fully liable and responsible for any travel time or other special charges by the service company, assuming they agree to make the service call. Further, to the extent you have installed the Product in a difficult-to-access location or have otherwise installed temporary or permanent fixtures that create barriers to accessing or removing the Product, Gaggenau will not incur any liability for, or have responsibility, for work or costs associated with moving the Product or otherwise creating access to the Product in order to repair or replace it. All such costs shall be your sole responsibility.

## 16.4 Out of warranty product

Gaggenau is under no obligation, at law or otherwise, to provide you with any concessions, including repairs, prorates, or Product replacement, once this warranty has expired.

## 16.5 Warranty exclusions

The warranty coverage described herein excludes all defects or damage that are not the direct fault of Gaggenau, including without limitation, one or more of the following:

- Use of the Product in anything other than its normal, customary and intended manner (including without limitation, any form of commercial use, use or storage of an indoor product outdoors, use of the Product in conjunction with air or water-going vessels).
- Any party's willful misconduct, negligence, misuse, abuse, accidents, neglect, improper operation, failure to maintain, improper or negligent installation, tampering, failure to follow operating instructions, mishandling, unauthorized service (including selfperformed "fixing" or exploration of the appliance's internal workings).
- Adjustment, alteration or modification of any kind.
- A failure to comply with any applicable state, local, city, or county electrical, plumbing and/or building codes, regulations, or laws, including failure to install the product in strict conformity with local fire and building codes and regulations.
- Ordinary wear and tear, spills of food, liquid, grease accumulations, or other substances that accumulate on, in, or around the Product.

- Any external, elemental and/or environmental forces and factors, including without limitation, rain, wind, sand, floods, fires, mud slides, freezing temperatures, excessive moisture or extended exposure to humidity, lightning, power surges, structural failures surrounding the appliance, and acts of God.
- Service calls to correct the installation of your Product, to instruct you how to use your Product, to replace house fuses or correct house wiring or plumbing.
- Removal and replacement of trim or decorative panels that interfere with servicing the Product.
- Damage or defects caused by labor or parts installed by any non-authorized service provider, unless approved by Gaggenau before service is performed.

In no event shall Gaggenau have any liability or responsibility whatsoever for damage to surrounding property, including cabinetry, floors, ceilings, and other structures or objects around the Product. Also excluded from this warranty are Products, on which the serial numbers have been altered, defaced, or removed; service visits to teach you how to use the Product, or visits where there is nothing wrong with the Product; correction of installation problems (you are solely responsible for any structure and setting for the Product, including all electrical, plumbing or other connecting facilities, for proper foundation/flooring, and for any alterations including without limitation cabinetry, walls, floors, shelving, etc.); and resetting of breakers or fuses.

TO THE EXTENT ALLOWED BY LAW, THIS WARRANTY SETS OUT YOUR EXCLUSIVE REMEDIES WITH RESPECT TO PRODUCT, WHETHER THE CLAIM ARISES IN CONTRACT OR TORT (INCLUDING STRICT LIABILITY, OR NEGLIGENCE) OR OTHERWISE. THIS WARRANTY IS IN LIEU OF ALL OTHER WARRANTIES, WHETHER EXPRESS OR IMPLIED. ANY WARRANTY IMPLIED BY LAW, WHETHER FOR MERCHANTABILITY OR FITNESS FOR A PARTICULAR PURPOSE, OR OTHERWISE, SHALL BE EFFECTIVE ONLY FOR THE PERIOD THAT THIS EXPRESS LIMITED WARRANTY IS EFFECTIVE. IN NO EVENT WILL THE MANUFACTURER BE LIABLE FOR CONSEQUENTIAL, SPECIAL, INCIDENTAL, INDIRECT, "BUSINESS LOSS", AND/OR PUNITIVE DAMAGES, LOSSES, OR EXPENSES, INCLUDING WITHOUT LIMITATION TIME AWAY FROM WORK, HOTELS AND/OR RESTAURANT MEALS, REMODELLING EXPENSES IN EXCESS OF DIRECT DAMAGES WHICH ARE DEFINITELY CAUSED EXCLUSIVELY BY GAGGENAU, OR OTHERWISE. SOME STATES DO NOT ALLOW THE EXCLUSION OR LIMITATION OF INCIDENTAL OR CONSEQUENTIAL DAMAGES, AND SOME STATES DO NOT ALLOW LIMITATIONS ON HOW LONG AN IMPLIED WARRANTY LASTS, SO THE ABOVE EXCLUSIONS OR LIMITATIONS MAY NOT APPLY TO YOU. THIS WARRANTY GIVES YOU SPECIFIC LEGAL RIGHTS, AND YOU MAY ALSO HAVE OTHER RIGHTS WHICH VARY FROM STATE TO STATE.

No attempt to alter, modify or amend this warranty shall be effective unless authorized in writing by an officer of BSH.

## 16.6 Obtaining warranty service

To obtain warranty service for your product, you should contact Gaggenau Customer Support at 1-877-442-4436 to schedule a repair.

## 16.7 Product information

For handy reference, copy the information below from the rating plate. Keep your invoice and/or delivery documents for warranty validation.

---

Model number (E-Nr.)

---

Production number (FD)

---

Date of delivery

---





The difference is Gaggenau

[gaggenau.com](http://gaggenau.com)

**BSH Home Appliances Corporation**

1901 Main Street, Suite 600

Irvine, CA 92614

USA

[www.gaggenau.com](http://www.gaggenau.com)

1-877-442-4436

© 2026 BSH Home Appliances Corporation



**9001959993** (060401)

en-us