

Built-in Microwave

GM450/451 720



You can find additional information and explanations online.
Scan the QR code on the title page.



Table of contents

1 Microwave energy	4	8.6 Opening the appliance door automatically after the cooking process	21
2 IMPORTANT SAFETY INSTRUCTIONS	5	8.7 Deactivating automatic appliance door opening	21
2.1 Safety definitions	5	8.8 Interrupting and continuing an operation	22
2.2 Microwave safety	5	8.9 Opening and closing the control center	22
2.3 Safe use	5	8.10 Switching the interior lighting on or off	22
2.4 GROUNDING INSTRUCTIONS	6	8.11 Switching off the appliance	22
2.5 TV / Radio interference	6	8.12 Switching on the appliance after automatic shut-off	22
2.6 Child safety	6	8.13 Displaying information	22
2.7 Cleaning safety	6	8.14 Displaying appliance information	22
2.8 Cooking safety	6	8.15 Using the quick guides	22
2.9 In case of fire	7	9 Microwave	22
2.10 Liquids	7	9.1 Microwave-safe cookware and accessories	22
2.11 Cooking items	7	9.2 Testing cookware for microwave suitability	23
2.12 Cooking utensils	8	9.3 Microwave power level	23
2.13 Pacemakers	8	9.4 Setting the microwave	23
2.14 Proper installation and maintenance	9	9.5 Interrupting and continuing microwave operation	23
2.15 State of California Proposition 65 Warnings	9	10 Oven	23
3 Preventing material damage	10	10.1 Types of heating in oven mode	23
3.1 General information	10	10.2 Setting the type of heating and temperature ...	25
3.2 Microwave	10	10.3 Add broiler	25
3.3 Core temperature probe	10	11 Combi-operation	25
4 Environmental protection and energy-saving	11	11.1 Setting combi-operation	25
4.1 Disposal of packaging	11	11.2 Removing the microwave operation	26
4.2 Saving energy	11	11.3 Switching from combi-operation to microwave operation	26
5 Familiarizing yourself with your appliance	11	12 Timer functions	26
5.1 Appliance	11	12.1 Overview of the timer functions	26
5.2 Oven cavity	11	12.2 Call up the timer menu	26
5.3 Control elements	12	12.3 Exiting the timer menu	26
5.4 Types of heating	15	12.4 Cooking time	27
5.5 Low power mode display	17	12.5 Cooking time end	27
5.6 Cooling fan	17	12.6 Count-up cooking timer	28
5.7 Additional information	17	13 Manual door opening aid	28
5.8 Pop-up notifications	17	13.1 Installing the manual door opening aid	28
5.9 Quick guides	17	13.2 Opening the appliance door using the manual door opening aid	29
5.10 Automatic switch-off	17	13.3 Cleaning the manual door opening aid	29
5.11 Proximity sensor	18	13.4 Removing the manual door opening aid	29
5.12 Wipe protection	18	14 Child lock	29
5.13 Door lock	18	14.1 Activating the childproof lock	29
6 Accessories	18	14.2 Deactivating the childproof lock	30
6.1 Other accessories	18	15 Programs	30
6.2 Sliding accessories into the oven cavity	19	15.1 Automatic programs	30
6.3 Microwave utensil guide	19	15.2 Recommended settings	31
7 Before using for the first time	20	16 Favorites	32
7.1 Initial use	20	16.1 Creating the first favorites	32
8 Basic Operation	20	16.2 Selecting a favorite	32
8.1 Switching on the appliance	20		
8.2 Opening the appliance door	20		
8.3 Changing the type of heating	21		
8.4 Changing the temperature	21		
8.5 Displaying the current interior oven temperature	21		

16.3	Renaming a favorite	32	20.3	Removing the shelf supports	44
16.4	Starting a favorite	32	20.4	Cleaning aid	44
16.5	Changing a favorite	32	20.5	Fitting the shelf supports	45
16.6	Deleting a favorite	32	20.6	Cleaning the accessories	45
17	Core temperature sensor	33	20.7	Cleaning the glass floor	45
17.1	Inserting the core temperature probe into the food	33	21	How it works	45
17.2	Turning the food	34	21.1	What is the best way to proceed?	46
17.3	Setting the core temperature probe	34	21.2	General cooking tips	46
17.4	Deleting the set core temperature	34	22	Troubleshooting	46
17.5	Changing the set core temperature	34	22.1	Malfunctions	46
17.6	Core temperature guideline values	35	22.2	Display information	47
17.7	Estimated cooking time	35	22.3	Demo mode	47
18	Home Connect®	35	23	Disposal	48
18.1	Setting up Home Connect®	36	23.1	Disposal of your old appliance	48
18.2	Home Connect® settings	36	24	Customer Service	48
18.3	Starting functions with the Home Connect® app via manual "Remote start"	36	24.1	Model number (E-Nr.), production number (FD) and consecutive numbering (Z-Nr.)	48
18.4	Starting functions with the Home Connect® app via permanently activated "Remote start"	36	24.2	Rating plate location	48
18.5	Using the Home Connect® app to change set- tings	37	25	Information regarding Free and Open Source Software	48
18.6	Switching the Wi-Fi on or off	37	26	STATEMENT OF LIMITED PRODUCT WARRANTY	49
18.7	Software update	37	26.1	What this warranty covers & Who it applies to	49
18.8	Data Protection	37	26.2	How long the warranty lasts	49
19	Basic settings	37	26.3	Repair/replace as your exclusive remedy	49
19.1	Overview of the basic settings	37	26.4	Out of warranty product	49
19.2	Changing the basic settings	42	26.5	Warranty exclusions	49
20	Cleaning and maintenance	43	26.6	Obtaining warranty service	50
20.1	Cleaning agents	43	26.7	Product information	50
20.2	Microfiber cloth	44			

1 Microwave energy

⚠ PRECAUTIONS TO AVOID POSSIBLE EXPOSURE TO EXCESSIVE MICROWAVE ENERGY

(1) Do not attempt to operate this appliance with the door open, since open-door operation can result in harmful exposure to microwave energy. It is important not to defeat or tamper with the safety interlocks.

(2) Do not place any object between the appliance front face and the door or allow soil or cleaner residue to accumulate on sealing surfaces.

(3) Do not operate the appliance if it is damaged. It is particularly important that the appliance door close properly and that there is no damage to the:

- door (bent)
- hinges and latches (broken or loosened)
- door seals and sealing surfaces.

(4) The appliance should not be adjusted or repaired by anyone except authorized service personnel. Improper installation, service or maintenance can cause injury or property damage. Refer to this manual for guidance.

Refer all servicing to a factory authorized service provider.



IMPORTANT SAFETY INSTRUCTIONS

READ ALL INSTRUCTIONS BEFORE USING THE APPLIANCE

WARNING - Read all instructions carefully before use. These precautions will reduce the risk of burns, electric shock, fire, injury to persons, or exposure to excessive microwave energy. When using kitchen appliances, basic safety precautions must be followed including those in the following pages.

2.1 Safety definitions

Here you can find explanations of the safety signal words used in this manual.

WARNING

This indicates that death or serious injuries may occur as a result of non-observance of this warning.

CAUTION

This indicates that minor or moderate injuries may occur as a result of non-observance of this warning.

NOTICE

This indicates that damage to the appliance or property may occur as a result of non-compliance with this advisory.

Note: This alerts you to important information and/or tips.

2.2 Microwave safety

WARNING

When using electrical appliances basic safety precautions should be followed, including the following:

- ▶ Read all instructions before using the appliance.
- ▶ Read and follow the specific PRECAUTIONS TO AVOID POSSIBLE EXPOSURE TO EXCESSIVE MICROWAVE ENERGY found on → *Page 4*
- ▶ This appliance must be grounded. Connect only to properly grounded outlet. See .
→ *"GROUNDING INSTRUCTIONS", Page 6*
- ▶ Install or locate this appliance only in accordance with the provided installation instructions.
- ▶ Some products such as whole eggs and sealed containers – for example, closed glass jars – are able to explode and should not be heated in this appliance.
- ▶ Use this appliance only for its intended use as described in the manual. Do not use corrosive chemicals or vapors in this appliance. This type of appliance is specifically designed to heat, cook, or dry food. It is not designed for industrial or laboratory use.
- ▶ **HOT CONTENTS CAN CAUSE SEVERE BURNS. DO NOT ALLOW CHILDREN TO USE THE MICROWAVE.** Use caution when removing hot items.
- ▶ Do not operate this appliance if it has a damaged cord or plug, if it is not working properly, or if it has been damaged or dropped.
- ▶ This appliance should be serviced only by an authorized service provider. Contact nearest authorized service provider for examination, repair, or adjustment.
- ▶ Do not cover or block any vents or openings on the appliance.
- ▶ Do not store this appliance outdoors. Do not use this product near water – for example, near a kitchen

sink, in a wet basement, near a swimming pool, or similar locations.

- ▶ Do not immerse cord or plug in water.
- ▶ Keep cord away from heated surface.
- ▶ Do not let cord hang over edge of table or counter.
- ▶ When cleaning surfaces of door and appliance that come together on closing the door, use only mild, non-abrasive soaps, or detergents applied with a sponge or soft cloth. See door surface cleaning instructions.
→ *"Cleaning and maintenance", Page 43*

2.3 Safe use

WARNING

If the information in this manual is not followed exactly, fire or shock may result causing property damage or personal injury.

This appliance is intended for normal family household use only. It is not approved for outdoor use. See the Statement of Limited Product Warranty. If you have any questions, contact the manufacturer.

This appliance is intended to be used in household and similar applications such as:

- ▶ staff kitchen areas in shops, offices and other working environments;
- ▶ farm houses;
- ▶ by clients in hotels, motels and other residential type environments;
- ▶ bed and breakfast type environments.

The microwave is intended for heating food and beverages.

Drying of food or clothing and heating of warming pads, slippers, sponges, damp cloth and similar may lead to risk of injury, ignition or fire.

WARNING

Do not operate the appliance when room humidity is excessive.

WARNING

To reduce the risk of fire in the appliance cavity

- ▶ Do not overcook food. Carefully attend appliance when paper, plastic, or other combustible materials are placed inside the appliance to facilitate cooking.
- ▶ Remove wire twist-ties from paper or plastic bags before placing the bag in the appliance.
- ▶ If material inside of the appliance should ignite, the appliance door should be kept closed, the appliance turned off, the power cord disconnected, or the power shut off at the fuse or circuit breaker panel.
- ▶ Do not use the appliance cavity for storage purposes. Do not leave paper products, cooking utensils, or food in the appliance cavity when not in use.

WARNING

The light emitted by LED lights is very dazzling, and can damage the eyes.

- ▶ Do not look directly into the switched-on LED lights for longer than 100 seconds.
- ▶ Do not look directly into the switched-on LED lights using optical aids such as binoculars or a magnifying glass.

SAVE THESE INSTRUCTIONS.



IMPORTANT SAFETY INSTRUCTIONS

READ ALL INSTRUCTIONS BEFORE USING THE APPLIANCE

WARNING

While cooking food items, small amounts of certain by-products, such as particulate matter / soot, can be released. To minimize exposure to these substances:

- ▶ Always ensure proper ventilation by using an appropriate ventilation fan or hood vented to the outside and/or an open window.
- ▶ Always operate the unit according to the instructions in this manual.

WARNING

Overheated materials can cause fire or burns and may produce potentially harmful smoke or fumes.

- ▶ To prevent overheating, turn ventilation hood ON when heating grease, fats or frying using medium to high heat settings.
- ▶ Avoid heating empty pots and pans.
- ▶ Do not allow pans to boil dry.
- ▶ Do not allow aluminum foil, plastic, paper, or cloth to come in contact with a hot surface element, burner, or grate.

2.4 GROUNDING INSTRUCTIONS

WARNING

This appliance must be grounded. Grounding reduces the risk of electric shock by providing a safe pathway for electric current in the event of a short circuit. Improper grounding can result in a risk of electric shock.

- ▶ Consult a qualified electrician if grounding instructions are not completely understood, or if doubt exists as to whether the appliance is properly grounded.
- ▶ Do not use an extension cord. If the power supply cord is too short, have a qualified electrician install an outlet near the appliance.

This appliance must be connected to a grounded, metallic, permanent wiring system, or an equipment grounding conductor should be run with the circuit conductors and connected to the equipment grounding terminal or lead on the appliance.

- ▶ The models stated on the front cover are dual-rated, designed to be connected to either 208 or 240V AC, 60 Hz, four-wire or three-wire electrical system.

2.5 TV / Radio interference

Avoid TV and radio interference by following these instructions.

This appliance generates and uses ISM frequency energy. If not installed and used properly, in strict accordance with the manufacturer's instructions, it may cause interference to radio and television reception. It has been type tested and found to comply with limits for ISM equipment pursuant to part 18 of FCC rules, which are designed to provide reasonable protection against such interference in a residential installation. However, there is no guarantee that interference will not occur in a particular installation. Turn the appliance on and off to determine if it causes interference.

Try the following to correct the interference:

- Clean door and sealing surface of the appliance.

- Reorient the receiving antenna of the radio or television.
- Relocate the appliance with respect to the receiver.
- Move the appliance away from the receiver.
- Plug the appliance into a different outlet so that the appliance and the receiver are on different branch circuits.
- The manufacturer is not responsible for any radio or TV interference caused by unauthorized modification to this appliance. It is the responsibility of the user to correct such interference.

2.6 Child safety

WARNING

Children should be supervised to ensure that they do not play with the appliance.

This appliance is not intended for use by persons (including children) with reduced physical, sensory or mental capabilities, or lack of experience and knowledge, unless they have been given supervision or instruction concerning use of the appliance by a person responsible for their safety.

Do not allow children to use this appliance. Failure to do so can result in burns or serious injury to children. Children and pets should not be left alone or unattended in the area where the appliance is in use. They should never be allowed to play in its vicinity, whether or not the appliance is in use.

WARNING

Do not allow anyone to climb, stand, lean, sit, or hang on any part of an appliance, especially a door, warming drawer, or storage drawer.

- ▶ This can damage the appliance, and the unit may tip over, potentially causing severe injury.

2.7 Cleaning safety

Follow these safety instructions when cleaning your appliance.

WARNING

Be sure the entire appliance has cooled and grease has solidified before attempting to clean any part of the appliance.

- When cleaning surfaces of door and appliance cavity that come together on closing the door, use only mild, non-abrasive soaps, or detergents applied with a sponge or soft cloth. See door surface cleaning instructions.

→ "Cleaning and maintenance", Page 43

2.8 Cooking safety

CAUTION

To avoid personal injury or property damage, observe the following:

- ▶ Do not leave the appliance unattended while in use.
- ▶ Do not store flammable material next to or in the appliance.
- ▶ Do not operate the appliance while empty. This could damage the appliance and result in a risk of fire.

SAVE THESE INSTRUCTIONS.



IMPORTANT SAFETY INSTRUCTIONS

READ ALL INSTRUCTIONS BEFORE USING THE APPLIANCE

- ▶ Do not store or use corrosive chemicals, vapors, flammables or nonfood products in or near this appliance. It is specifically designed for use when heating or cooking food. The use of corrosive chemicals in heating or cleaning will damage the appliance and could result in injury.
- ▶ Do not dry clothes, newspapers or other materials in the appliance. Do not use newspapers or paper bags for cooking. Fire could result.
- ▶ Do not use recycled paper products unless labeled safe for microwave use. They may contain impurities which may cause sparks and result in fires when used.
- ▶ Always use potholders when removing items from the appliance. The cooking container and the glass tray can be hot even if the appliance is cool.
- ▶ Whenever possible, do not operate the ventilation system during a cooktop fire. However, do not reach through fire to turn it off.
- ▶ Do not mount over a sink.
- ▶ Do not store anything directly on top of the appliance surface when the appliance is in operation.
- ▶ Oversized food or oversized metal utensils should not be inserted in a microwave as they may create a fire or risk of electric shock.
- ▶ Do not clean with metal scouring pads. Pieces can break off the pad and touch electrical parts involving a risk of electric shock.
- ▶ Do not use paper products when appliance is operated in the toaster mode.
- ▶ Do not store any materials, other than manufacturer's recommended accessories, in this appliance when not in use.
- ▶ Do not cover racks or any other part of the appliance with metal foil. This will cause overheating of the appliance.

2.9 In case of fire

WARNING

If smoke is observed, switch off or unplug the appliance and keep the door closed in order to stifle any flames.

If materials inside an appliance should ignite:

- Keep the appliance door closed.
- Turn the appliance off.
- Unplug the appliance or shut off at fuse or circuit breaker.

2.10 Liquids

WARNING

Liquids such as water, coffee, or tea are able to be overheated beyond the boiling point without appearing to be boiling. Visible bubbling or boiling when the container is removed from the microwave is not always present.

THIS COULD RESULT IN VERY HOT LIQUID SUDDENLY BOILING OVER WHEN THE CONTAINER IS DISTURBED OR A SPOON OR OTHER UTENSIL IS INSERTED INTO THE LIQUID.

- ▶ When heating liquids, always place a glass rod/ spoon in the container. This will prevent delayed boil-

ing.

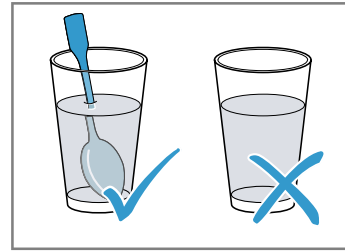

Microwave heating of beverages can result in delayed eruptive boiling, therefore care must be taken when handling the container.

CAUTION

Metal e.g. a spoon in a glass must be kept at least 1" (25 mm) from the appliance walls and the inside of the door.

Sparks could irreparably damage the glass on the inside of the door.

Follow these recommendations when cooking with your microwave:

- Take ready meals out of the packaging. They will heat up more quickly and evenly in microwaveable ovenware. The different components of the meal may not require the same amount of time to heat up.
- Always cover the food. If you do not have a suitable cover for your container, use a plate or special microwave foil.
- Stir or turn the food several times during cooking. Check the temperature.
- After heating, allow the food to stand for a further 2 to 5 minutes so that it can achieve an even temperature.
- Always use an oven cloth or oven gloves when removing plates from the appliance.

2.11 Cooking items

Follow these safety instructions when cooking food in your microwave to avoid injury.

- Eggs:
 - Eggs in their shell and whole hard-boiled eggs should not be heated in the microwave since they may explode, even after microwave heating has ended.
 - Reheating sliced hard-boiled eggs and cooking scrambled eggs is safe.
- Popcorn:
 - Use only popcorn in packages designed and labeled for microwave use, or pop it in a microwave corn popper.
 - Follow popcorn manufacturers' directions and use a brand suitable for the wattage of your appliance.
 - Do not continue to heat after popping has stopped. Popcorn will scorch or burn.
 - Do not leave the appliance unattended.

SAVE THESE INSTRUCTIONS.



IMPORTANT SAFETY INSTRUCTIONS

READ ALL INSTRUCTIONS BEFORE USING THE APPLIANCE

CAUTION

When using pre-packaged microwave popcorn, check package weight before using the popcorn function.

▶ Set the appliance for the weight of the popcorn package. If these instructions are not followed, popcorn may not pop adequately or may ignite and cause fire.

■ Foods with non-porous skins:

Potatoes, tomatoes, sweet potatoes, apples, whole squash and sausages are examples of foods with nonporous skins. These types of foods must be pierced before cooking to prevent them from exploding.

■ Baby food / Baby formula:

Do not heat baby bottles or food in a microwave. The glass jar or the surface of food may appear warm while the interior can burn the infant's mouth and esophagus.

■ Deep fat frying:

– Do not deep fat fry in the appliance. Oil can be heated beyond ideal temperatures very quickly in a microwave. Temperatures can climb high enough for the cooking oils to reach their respective flash points and burst into flames. The heated oil may bubble and spatter causing possible damage to the appliance and perhaps result in burns.

– Additionally, microwave-safe utensils may not be able to withstand the temperature of the hot oil, and could result in the utensil shattering, if it contains a slight imperfection, scratch or chip.

■ Home Canning / Drying foods / Small quantities of foods:

– Do not use the microwave for home canning or heating of any closed jar. Pressure will build up and the jar may explode. In addition, the appliance cannot maintain the food at the proper canning temperature. Improperly canned food may spoil and be dangerous to consume. Small quantities of food or foods with low moisture content can dry out, burn or catch on fire. Do not dry meats, herbs, fruits or vegetables in your appliance.

– Proper cooking depends on time set and weight of food. If you use a smaller portion than recommended and cook at the time for the recommended portion, fire could result.

■ Browning dishes:

– Microwave browning dishes or grills are designed for microwave cooking only. Preheating times vary depending on the size of the browning dish and food being cooked.

– Always follow instructions provided by the browning dish or grill manufacturer.

– Do not preheat browning dishes more than 6 minutes.

■ Oven roasting bags:

– If an oven bag is used for microwave cooking, prepare according to package directions.

– Do not use wire twist-ties to close bags, instead use nylon ties, cotton string or a strip cut from the open end of the bag. Make six ½" (12.7 mm) slits by closure.

– Place the oven cooking bag in a dish slightly larger than the food being cooked.

2.12 Cooking utensils

Only use utensils that are suitable for use in microwave ovens.

CAUTION

Incorrect use of cooking utensils can result in injuries or property damage.

▶ Only use utensils that are suitable for use in microwave appliances. See also Microwave Utensil Guide → *Page 19*.

▶ Cooking utensils, the glass tray and racks get hot during microwaving. Always use potholders when removing items from the appliance. Allow the glass tray and the metal racks (if used) to cool before handling.

▶ Metallic containers for food and beverages are not allowed during microwave cooking.

▶ Do not use metal utensils, or dishes with metallic trim in the appliance.

▶ When using aluminum foil in the appliance, allow at least 1" (25 mm) of space between foil and interior appliance walls or door.

▶ The glass tray and the metal racks (if used) will get hot during cooking. The cooking container and the glass tray can be hot even if the appliance is cool.

▶ Never use paper, plastic, or other combustible materials that are not intended for cooking.

▶ When cooking with paper, plastic, or other combustible materials, follow manufacturer's recommendations on product use.

▶ When heating food in plastic or paper containers, keep an eye on the appliance due to the possibility of ignition.

▶ Do not use paper towels which contain nylon or synthetic fibers. Heated synthetics could melt and cause paper to ignite.

▶ Do not heat sealed containers or plastic bags in the appliance. Food or liquid could expand quickly and cause container or bag to break. Pierce or open container or bag before cooking.

▶ Do not use regular cooking thermometers in the appliance. Most cooking thermometers contain mercury and may cause electrical arc, malfunction, or damage to the appliance.

2.13 Pacemakers

CAUTION

To avoid pacemaker malfunction, consult physician or pacemaker manufacturer about effects of microwave energy on pacemaker.



IMPORTANT SAFETY INSTRUCTIONS

READ ALL INSTRUCTIONS BEFORE USING THE APPLIANCE

2.14 Proper installation and maintenance

WARNING

This appliance must be mounted at a minimum height of 36" (914 mm).

If the door or door seals are damaged, the oven must not be operated until it has been repaired by a competent person.

It is hazardous for anyone other than a competent person to carry out any service or repair operation that involves the removal of a cover which gives protection against exposure to microwave energy.

The appliance should be cleaned regularly and any food deposits removed.

Failure to maintain the oven in a clean condition could lead to deterioration of the surface that could adversely affect the life of the appliance and possibly result in a hazardous situation.

2.15 State of California Proposition 65

Warnings

This product may contain a chemical known to the State of California, which can cause cancer or reproductive harm. Therefore, the packaging of your product may bear the following label as required by California:

STATE OF CALIFORNIA PROPOSITION 65 WARNING:

 **WARNING**

Cancer and Reproductive Harm - www.P65Warnings.ca.gov

SAVE THESE INSTRUCTIONS.

3 Preventing material damage

3.1 General information

NOTICE

Alcoholic vapors may catch fire in the hot cooking compartment and cause permanent damage to the appliance. The appliance door may spring open due to an explosion and it may fall off. The door panels may shatter and fragment. Due to the resulting negative pressure, the cooking compartment may become considerably deformed inwards.

- ▶ Do not heat spirits ($\geq 15\%$ vol.) when undiluted (e.g. for marinating or pouring over food).

When the oven cavity is hot, any water inside it will create steam. The change in temperature that occurs as a result may cause damage.

- ▶ Never pour water into the oven cavity when it is still hot.

Carrying the appliance by the appliance frame may cause it to bend. The appliance frame cannot support the weight of the appliance.

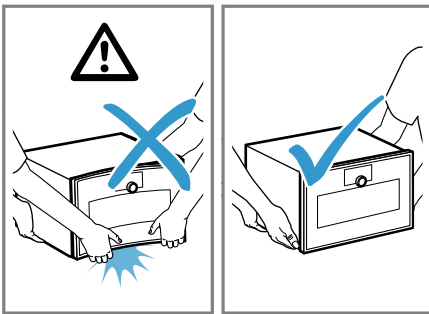

- ▶ Do not lift the appliance using the appliance frame.
- ▶ Always lift the appliance at the casing.

The prolonged presence of moisture in the oven cavity leads to corrosion.

- ▶ Always wipe away the condensation after cooking. Always allow the oven cavity to cool down with the door closed after cooking at high temperatures.
- ▶ Do not keep moist food in the closed oven cavity for extended periods of time.
- ▶ Do not store food in the oven cavity.
- ▶ Do not trap anything in the appliance door.

If the seal is very dirty, the appliance door will no longer close properly during operation. The fronts of adjacent units could be damaged.

- ▶ Always keep the seal clean.
- ▶ Never operate the appliance if the seal is damaged or missing.

Sitting or placing objects on the appliance door may damage it.

- ▶ Do not place, hang or support objects on the appliance door.
- ▶ Do not place any cookware or accessories on the appliance door.

3.2 Microwave

Follow these instructions when using the microwave.

NOTICE

Metal touching the wall of the cooking compartment will cause sparks, which may damage the appliance or the inner door pane.

- ▶ Metal (e.g. a spoon in a glass) must be kept at least 2 cm from the cooking compartment walls and the inside of the door.

Placing aluminum containers in the appliance may cause sparks. They damage the appliance by producing sparks.

- ▶ Do not use aluminum containers in the appliance. Operating the appliance without food in the cooking compartment may lead to overloading.
- ▶ Do not switch on the microwave unless there is food inside. The only exception to this rule is when performing a short cookware test.

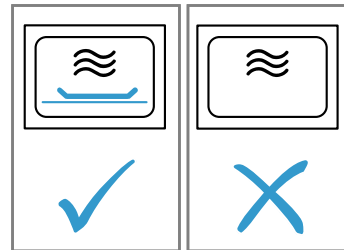

If you prepare several bags of microwave popcorn in immediate succession at a microwave output level that is too high, the cooking compartment may be damaged.

- ▶ Leave the appliance to cool down for several minutes between each use.
- ▶ Never set a microwave output level that is too high.
- ▶ Use a maximum microwave output of 600 watts.
- ▶ Always place the popcorn bag on a glass plate or on the cooking compartment floor.

Using unsuitable cookware may result in damage.

- ▶ When using the grill, the microwave combi-operation mode or the hot air mode, only use cookware that can withstand the high temperatures.

Loose knurled screws may cause sparks to form during microwave operation.

They damage the appliance by producing sparks.

- ▶ Ensure that the knurled screws for installing the shelf supports are screwed in tightly.

3.3 Core temperature probe

WARNING

An incorrect core temperature probe may damage the insulation.

- ▶ Only use the core temperature probe that is suitable for this appliance.

NOTICE

You may damage the cable of the core temperature probe with the appliance door.

- ▶ Do not trap the cable of the core temperature probe in the appliance door.

The heat of the grill heating element may damage the core temperature probe.

- ▶ Ensure that the distance between the grill heating element and the core temperature probe and the cable

of the core temperature probe is a few centimeters. In doing so, ensure that the meat can expand during the cooking process.

Aggressive cleaning agents may damage the core temperature probe.

- ▶ Do not clean the core temperature probe in the dishwasher.

4 Environmental protection and energy-saving

4.1 Disposal of packaging

The packaging materials are environmentally compatible and can be recycled.

- ▶ Sort the individual components by type and dispose of them separately.

4.2 Saving energy

If you follow these instructions, your appliance will use less power.

Use dark-colored, black-coated or enameled baking tins.

- ✓ These types of baking tin absorb the heat particularly well.

Only preheat the appliance if the recipe or the recommended settings tell you to do so.

- ✓ Not preheating the appliance can reduce the energy used.

When cooking multiple dishes, do so in succession or in parallel.

- ✓ The oven cavity is heated after cooking the first dish. This reduces the cooking time for the following dishes.

Open the appliance door as little as possible during operation.

- ✓ This maintains the temperature in the oven cavity and eliminates the need for the appliance to reheat.

If the cooking time is relatively long, you can switch the appliance off 10 minutes before the cooking time ends.

- ✓ There will be enough residual heat to finish cooking the dish.

5 Familiarizing yourself with your appliance

This Use and Care Manual covers several models. Your model may have some but not all of the features listed.

5.1 Appliance

Here you can find an overview of the parts of your appliance.

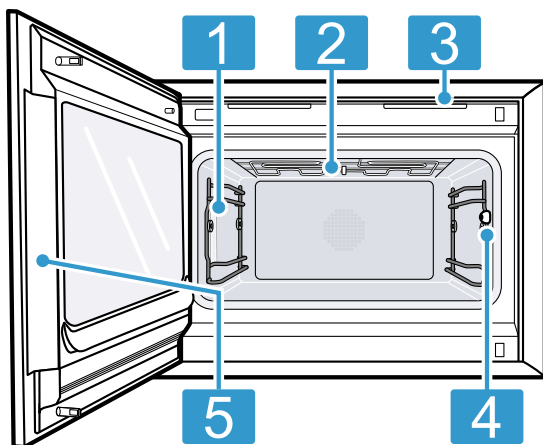

- | | |
|---|---|
| 1 | Interior lighting |
| 2 | Grill element |
| 3 | Ventilation slots |
| 4 | Connection socket for core temperature probe
→ Page 33 |
| 5 | Intended area for opening the door |

5.2 Oven cavity

The oven cavity has two shelf levels. Count the shelf levels from the bottom up.

NOTICE

The accessories may tip.

- ▶ Do not push the accessories between the shelf positions.

Use shelf level 1 for deeper baking tins.

You can also remove the shelf supports → Page 44 and cook on the oven cavity floor.

The oven cavity floor is particularly suitable for microwave operation. The microwave output is best on the oven cavity floor. Only use microwave-safe cookware.

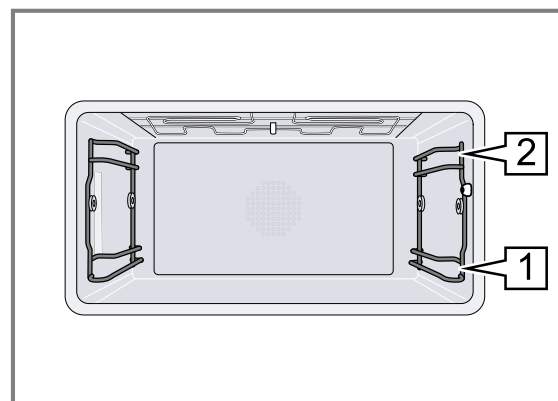

Interior lighting

When you open the appliance door, the interior lighting switches on. If the appliance door remains open for

longer than around 3 minutes, the interior lighting switches off.

⚠ WARNING

The light emitted by LED lights is very dazzling, and can damage the eyes (risk group 1).

- ▶ Do not look directly into the switched on LED lights for longer than 100 seconds.

You can also switch on the interior lighting when the appliance is in low power mode.

After approximately 20 minutes, the appliance switches the interior lighting off.

When you switch on the appliance, the appliance switches the interior lighting on.

→ "Switching the interior lighting on or off", Page 22

In most operating modes, the appliance keeps the interior lighting switched on.

You can specify whether the appliance will switch the interior lighting on during operation in the basic settings → Page 37. If you select the "Manual" setting in the basic settings, the appliance does not switch on the interior lighting automatically but you can switch on the interior lighting when required. After approximately 20 seconds, the appliance switches the interior lighting off.

Condensation

Condensation can occur in the cooking compartment and on the appliance door when cooking. Condensation is normal and does not adversely affect appliance operation. Wipe away the condensation after cooking.

5.3 Control elements

You can use the control panel to configure all functions of your appliance and to obtain information about the operating status.

On certain models, specific details may differ from those pictured.

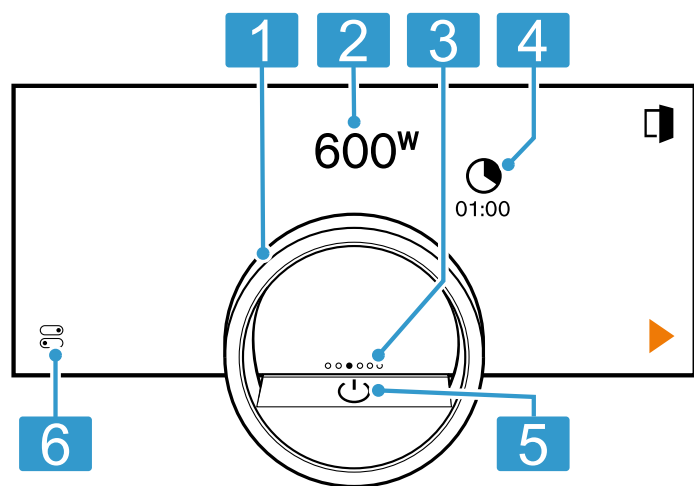

2	12 o'clock position	The 12 o'clock position shows the value that is currently selected for a function, which you can change using the control ring. If required, press on another function, e.g. on the temperature or cooking time, to position this at the 12 o'clock position.
3	Position indicator	The filled point on the display in the middle of the control ring shows the current horizontal navigation position between the appliance displays.
4	Symbols	Show settings, and start or end functions.
5	On/off button	Switch the appliance on and off.
6	Status bar & Control center	The status line shows the current status of functions or appliance components, e.g.: <ul style="list-style-type: none"> ▪ Home Connect® connection status ▪ Child protection Press  to open the control center → Page 15.

Control ring

Operation using the control ring is only possible when the appliance is switched on. You can use the control ring to navigate through the ring menus or the list menus and select settings.

When you touch the control ring, the display shows a ring in orange behind the control ring.

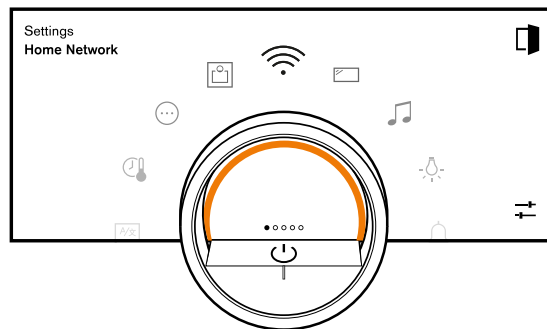

While operating the appliance, you can only use the control ring if you first select a function on the display.

Turn	Navigate in ring menus and list menus: <ul style="list-style-type: none"> ▪ Turn the control ring to the right to increase the values. ▪ Turn the control ring to the left to decrease the values. ▪ Turn the control ring to the right or left quickly to change the values in larger increments.
------	---

You can set how the control ring behaves in the basic settings → Page 37. In the "Standard" setting, press on the required function on the display and use the control ring to change the value of the function.

In the "Quick selection" setting, use the control ring, which is at the 12 o'clock position, to directly change the values for the function.

Process visualization

For process visualization, the appliance shows a section of a circle in orange behind the control ring.

The appliance shows the section of a circle in orange behind the control ring under the following conditions:

- A cooking time is set.
- A core temperature is set for the core temperature probe.

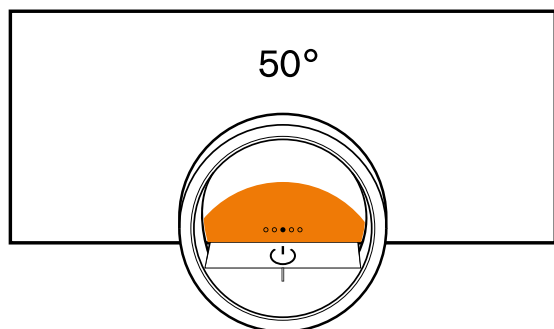

The section of the circle in orange becomes larger the longer the timer runs or the closer the core temperature of the food approaches the set core temperature. If no cooking time and no core temperature are set, the section of the circle pulsates in orange.

Display

The display shows the selected settings and setting options, as well as messages about the appliance's operating status.

Press	Selects or confirms the procedure or function
Press and hold	Displays additional information
Swipe horizontally	Navigates between appliance displays For example, in the "Microwave" appliance display, swipe to the left or right Note: You can only use the function if you are in an appliance display → <i>Page 14</i> and no program is running.

Note: If no display language is available in your national language, select a display language that is available, e.g. English.

Symbols

Use the symbols to start or stop functions, or to navigate in the appliance menu.

Operation

Symbol	Function
	Switch the appliance on or off at the control ring
	Opening the appliance door → <i>Page 20</i>

Symbol	Function
	Open the control center → <i>Page 22</i>
	Edit settings
	Call up additional information → <i>Page 22</i>
	Save a favorite → " <i>Favorites</i> ", <i>Page 32</i>
	Edit a favorite
	Deleting a favorite
	Tip for calling up programs → <i>Page 30</i>
	Start
Max.	Selecting the maximum microwave output
	Pause or stop
	Switch to the next step
	Switch to the previous step
	Back or accept settings
	Next
	Confirm
	Delete
	Reset
	Cancel
	Adding → <i>Page 25</i> or deleting microwave operation → <i>Page 26</i>
	Turning on the broiler

Timer functions

Symbol	Function
	Call up the timer menu → <i>Page 26</i>
	Delaying the cooking time end → <i>Page 28</i>
	Reset the cooking time to the preset cooking time → " <i>Changing the cooking time</i> ", <i>Page 27</i> Reset the delay of the cooking time end → " <i>Resetting the delay of the cooking time end</i> ", <i>Page 28</i>







Cleaning and maintenance

Symbol	Function
	Cleaning aid → <i>Page 44</i>

Operation in the control center





Symbol	Function
	Opening the appliance door automatically after the cooking process → <i>Page 21</i>
	Activate child lock → <i>Page 29</i>
	Switch the interior lighting on or off → <i>Page 22</i>
	Start functions with the Home Connect® app via manual "Remote start" → " <i>Starting functions with the Home Connect® app via manual 'Remote start'</i> ", <i>Page 36</i>
	Home Connect® Call up settings → " <i>Home Connect® settings</i> ", <i>Page 36</i>

Status

	Remote start → <i>Page 36</i>
	Core temperature probe is inserted → <i>"Core temperature sensor", Page 33</i>
	Core temperature probe is missing
	Status display for the heating process
	Display of a cooling process
	Appliance is in demo mode → <i>Page 47</i>

Status in the control center

Symbol	Function
	Connection to the router: Strong → <i>"Home Connect®", Page 35</i>

Symbol	Function
	Connection to the router: OK → <i>"Home Connect®", Page 35</i>
	Connection to the router: Weak → <i>"Home Connect®", Page 35</i>
	No connection to the router. → <i>"Home Connect®", Page 35</i>
	Appliance connected to the router. No connection to the Home Connect server. → <i>"Home Connect®", Page 35</i>
	Software update status

Appliance displays

You can find an overview of the appliance displays here.

Appliance displays	Usage	Navigation symbol
Settings	<ul style="list-style-type: none"> Adjusting the basic settings → <i>Page 37</i> Adjusting the Home Connect® settings → <i>Page 35</i> 	●○○○○○
Modes & Service	<ul style="list-style-type: none"> Starting the cleaning aid → <i>Page 44</i> Starting the quick guide → <i>Page 22</i> 	○●○○○○
Microwave	Setting the microwave output → <i>Page 23</i> and cooking time → <i>Page 26</i>	○○●○○○
"Manual" (oven mode, combi-operation)	Setting the type of heating, microwave activation → <i>Page 23</i> and cooking time → <i>Page 26</i>	○○○●○○
Favorites	Calling up favorites → <i>Page 32</i>	○○○○●○
Programs	Calling up automatic programs and recommended settings → <i>Page 30</i>	○○○○○●

Tip: In the basic settings → *Page 37*, you can set which appliance menu your appliance starts in.

Colors

The different colors are used to guide the user in the relevant setting situations.

Red	<ul style="list-style-type: none"> Error messages for which you may need the help of customer service.
Orange	<ul style="list-style-type: none"> Information that you must observe so that you can continue to use your appliance Symbols for starting and stopping
White	<ul style="list-style-type: none"> Information Additional information

Appearance

Depending on the situation, the appearance of symbols, values or the entire display changes.

Zooming in ring menus and list menus

When you use the control ring to select a list entry in a list menu, the display enlarges this list entry and displays it as underlined. When you use the control ring to select a value in a ring menu, the display shows this value enlarged in the 12 o'clock position.

Zoom at end of cooking or core temperature probe

A few minutes before the cooking process ends, the appliance shows the remaining cooking time enlarged in the center of the display. As soon as the current core temperature is just a few degrees below the set value, the display shows the current core temperature enlarged.

All other displays are hidden.

Pared-down display

If the appliance does not detect a user in the immediate vicinity, the appliance reduces the amount of information shown on the display and only the most important information remains. This function is preset. You can change the setting in the basic settings → *Page 37*.

You can activate or deactivate functions in the control center.

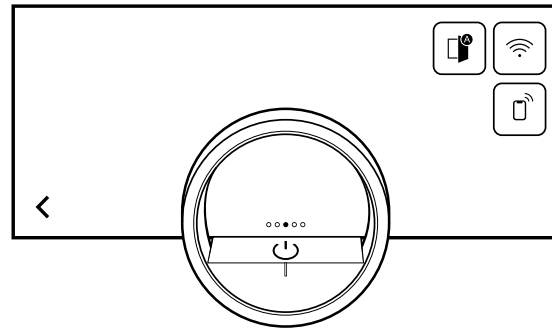

On the left-hand side, the display shows the symbols and texts with information on the current status of the appliance. On the right-hand side, the display shows the touch fields of the control center.

Control center

The control center  provides you with access to functions that are only visible in the status bar via symbols.



5.4 Types of heating







Here you can find an overview of the functions. You will find recommendations for using the types of heating.

Microwave function

Symbols	Function	Performance	Use
90	Microwave	90 W	Defrost delicate foods.
180	Microwave	180 W	Defrost foods.
360	Microwave	360 W	Defrost foods or cook gently.
450	Microwave	450 W	Cook foods or warm up gently.
600	Microwave	600 W	Cook foods or warm up.
Max.	Microwave	1000 W	Quickly heat liquids When the appliance is cold, full microwave output of 1000 W is available.



Oven functions

Symbols	Function/type of heating	Temperature/setting	Performance	Use
	Convection	86-445°F (30-230°C)		The heat arises from the back wall of the cooking compartment and is distributed quickly and evenly by the fan. For cooking on one or two levels with an extremely short preheating time. For moist cakes, cookies, bakes. To reduce the cooking time, the microwave can be switched on.
	Broil + circulated air	86-445°F (30-230°C)		For au gratin dishes at the end of the cooking time at 445 °F (230 °C). For grilling vegetable skewers and shrimp skewers at 355 °F (180 °C). Extremely intensive heat from above, which is distributed quickly and evenly by the fan. Guarantees that a crust is formed with simulta-

Symbols	Function/type of heating	Temperature/setting	Performance	Use
				neous all-round heating. For meat, poultry, fish, vegetable skewers. No preheating is required. To reduce the cooking time, the microwave can be switched on.
	Drying	86-176°F (30-80°C)		For drying thin slices of fruit or vegetables or herbs. Moisture is actively extracted from the cooking compartment.
	Low-temperature cooking	86-194°F (30-90°C)	90 W	Slow and gentle cooking of meat for a particularly tender result. Hot air is combined with a low microwave output in order to reduce the cooking time. Briefly sear meat before cooking.
	Dough proofing	86-122°F (30-120°C)		Optimal temperature range for proving dough batches and pieces of dough. For yeast dough and sourdough. The optimal temperature setting for yeast dough is 100 °F (38 °C).
	Keeping warm		50 W	Optimal microwave output for keeping food warm without it drying out.
	Defrosting		90-360 W	Optimal microwave output range for quickly and gently defrosting frozen food. Use 90 W for delicate foods.
	Warming up beverages		max.	Optimal microwave output for quickly heating liquids such as water and milk.
	Reheat meals		360-600 W Default power 360 W	Optimal microwave output range for heating up cooked meals, such as plated meals, bakes and soups.

MicroCombi function

You can add the microwave function for the following types of heating.

Symbols	Function	Temperature/setting	Use
	Convection	86-445°F (30-230°C)	The heat arises from the back wall of the cooking compartment and is distributed quickly and evenly by the fan. For cooking on one or two levels with an extremely short preheating time. For moist cakes, cookies, bakes. To reduce the cooking time, the microwave can be switched on.
	Broil + circulated air	86-445°F (30-230°C)	For au gratin dishes at the end of the cooking time at 445 °F (230 °C). For grilling vegetable skewers and shrimp skewers at 355 °F (180 °C).

Symbols	Function	Temperature/setting	Use
			Extremely intensive heat from above, which is distributed quickly and evenly by the fan. Guarantees that a crust is formed with simultaneous all-round heating. For meat, poultry, fish, vegetable skewers. No preheating is required. To reduce the cooking time, the microwave can be switched on.

5.5 Low power mode display

The appliance has different displays in low power mode. The displays depend on whether or not the appliance detects a user.

On the display without user detection, the appliance is switched off and the display is black. The appliance switches to low power mode without user detection if, when the appliance is switched on, you do not implement any settings for approx. 20 minutes or approx. 20 minutes after the appliance has completed a heating process.

If the proximity sensor detects a user or if you touch the control ring or press on the display, the appliance switches to low power mode with user detection.

In low power mode with user detection, the display shows the door opening symbol and the status bar. In the basic settings → *Page 37*, you can select whether the display also shows the GAGGENAU logo.

If the appliance is connected to the Home Connect® app, the display shows .

→ *"Home Connect®", Page 35*

The user detection distance depends on the selected basic settings.

In low power mode with user detection, the display brightness is reduced. The brightness of the display depends on the viewing angle.

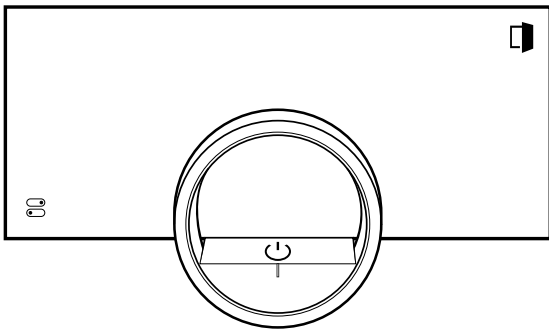

5.6 Cooling fan

The cooling fan switches on when the appliance is in operation. The hot air escapes above the door.

After removing your food from the appliance, keep the door closed until the appliance has cooled down. The appliance door must not be left half open as this may damage adjacent kitchen units. The cooling fan continues running for a certain period of time after the appliance has stopped heating and then it switches itself off automatically.

Do not cover the ventilation slots. Otherwise, the appliance may overheat.

5.7 Additional information

If required, you can display additional information.

When you press on , the display shows additional information about the current function.

When you press and hold certain symbols or values, the display shows additional information about the current function. Additional information is available for all symbols that are arranged around the control ring, e.g. information about the set type of heating or current interior oven temperature.

In the basic settings → *Page 37*, you can activate or deactivate the "Info-i" function.

The appliance also occasionally displays important information about safety and the operating status automatically. These messages disappear automatically after a few seconds, or when you press  to confirm the message.

For messages about Home Connect®, the appliance also displays the Home Connect® status.

→ *"Home Connect®", Page 35*

5.8 Pop-up notifications

Pop-up notifications contain explanations about current functions.

In the basic settings → *Page 37*, you can activate or deactivate the "Pop-up hints" function.

5.9 Quick guides

Your appliance comes with a quick guide to help you with various topics.

5.10 Automatic switch-off

For your protection, the appliance is equipped with an automatic shut-off function. The appliance switches off every heating process after a certain period of time if you do not operate the appliance or program a cooking time during this time. For types of heating without the microwave, the appliance switches off the heating process after 12 hours, and for types of heating with the microwave, after 90 minutes. If you use the maximum microwave output level, the appliance switches off the heating process after 30 minutes. The display shows a message.

If you set a cooking time, you can use the appliance for longer.

If you set a cooking time, you can operate the appliance in the "Convection", "Broil + circulated air", "Low-temperature cooking" or "Dough proofing" type of heating for a maximum of 24 hours. With the "Drying" type of heating, you can operate the appliance for a maximum of 72 hours.

When programming with the "Sabbath mode" function, the appliance switches off after up to 74 hours.

5.11 Proximity sensor



Your appliance detects whether you are in front of the appliance or moving towards it. Your appliance disregards if you are passing in front of it. If you do not remain in the detection zone for the appliance when it is switched on, the appliance reduces the display to what is essential.

Note: You can set the distance at which the appliance can detect you in the basic settings. To ensure that the proximity sensor optimally detects the user, set the installation height of the appliance's upper edge in the basic settings → Page 37.

5.12 Wipe protection

Your appliance detects if you would like to clean the display or navigate between the appliance displays. The appliance locks the operation via the display and the control ring for a short time. Press the display to return to the operation.

5.13 Door lock

The "Door lock" function prevents the appliance door from being opened accidentally. This is particularly useful when installing the appliance under the countertop. In the basic settings → Page 37, you can activate or deactivate the "Door lock" function. When you activate the function and press , the display shows a slide control instead of the  symbol. → "Opening the appliance door", Page 20

6 Accessories

Only use genuine accessories. These are designed especially for your appliance. The accessories supplied may differ depending on the appliance model.

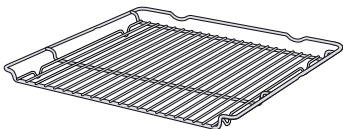
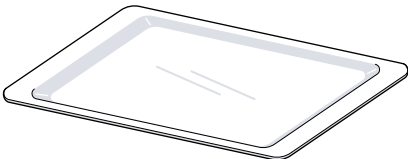
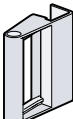
Accessories	Use
Wire rack	 <ul style="list-style-type: none"> ▪ Cookware ▪ Cake tins ▪ Broiled items ▪ Frozen meals ▪ Microwave-safe <p>Tip: You can pull the wire rack $\frac{2}{3}$ of the way out without it tipping. You can therefore remove dishes more easily.</p>
Glass tray	 <ul style="list-style-type: none"> ▪ Large roasts ▪ Moist cakes ▪ Bakes ▪ Gratins ▪ Splash guard when broiling directly on the wire rack <p>When broiling, slide the glass tray in at level 1.</p> <ul style="list-style-type: none"> ▪ Microwave-safe <p>Tip: You can use the glass tray as a setdown area during microwave operation. When the appliance is in microwave-only mode, you can also place the glass tray on the cooking compartment floor.</p>
Manual door opening aid	 <p>Open the door without using the automatic door opening button, e.g. on the Sabbath.</p>

6.1 Other accessories

You can purchase other accessories from our Customer Service, specialist retailers or online. You will find a comprehensive range of products for your appliance in our brochures and online: www.gaggenau.com Accessories are appliance-specific. When purchasing, always check for compatibility with your appliance model number (E-Nr).

You can find out which accessories are available for your appliance in our online shop or from our Customer Service.

Other accessories	Order number
Core temperature sensor	BA010050
Glass tray	BA046118
Wire rack	BA036166

6.2 Sliding accessories into the oven cavity

The wire rack is equipped with a locking function. For the tilt protection to work correctly, always insert the wire rack into the oven cavity the right way round.

NOTICE

The accessories may tip.

- ▶ Do not push the accessories between the shelf positions.

1. When inserting the wire rack, ensure that the lug  is facing downwards.

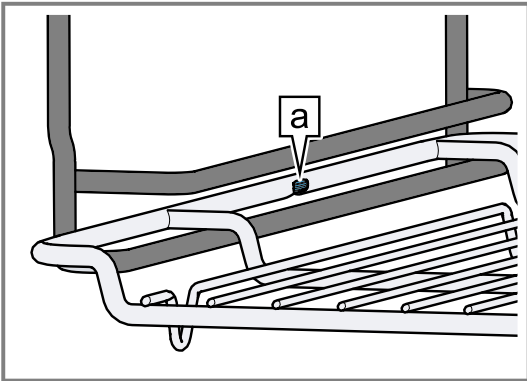

2. Ensure that the safety bracket on the wire rack is located at the rear and is facing upwards.

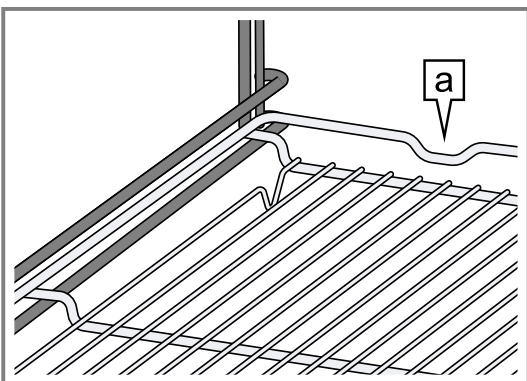

Note: To completely pull out the wire rack, lift it up slightly and pull it out with both hands. Remove any accessories that you do not require from the oven cavity.

6.3 Microwave utensil guide

Read here to see if your cooking utensils are suitable to be used in the microwave.

Suitable ovenware

Ovenware	Examples
Heat-resistant glass, glass ceramic and earthenware	Utility dishes, loaf dishes, pie plates, cake plates, liquid measuring cups, casseroles and bowls without metallic trim, such as Pyrex [®] , Anchor Hocking [™] , Corning Ware [®] , Emile Henry, etc. ¹

Ovenware	Examples
China	Bowls, cups, serving plates and platters without metallic trim.
Plastic films and wraps	Plastic wrap, as a cover: <ul style="list-style-type: none"> ▪ Lay the plastic wrap loosely over the dish and press it to the sides. ▪ Vent plastic wrap by turning back one edge slightly to allow excess steam to escape. ▪ The dish should be deep enough so that the plastic wrap will not touch the food.
Microwave-safe plastics	Microwave-safe plastic dishes, cups, semi-rigid freezer containers and plastic bags for short cooking times. Use these with care because the plastic may soften from the heat of the food.
Paper products	Paper towels, wax paper, parchment paper, paper napkins and paper plates with no metallic trim or design. Refer to the manufacturers label for any special instructions for use in the microwave.

Unsuitable ovenware

Ovenware	Examples
Metal utensils and cookware	Avoid metal in the appliance cavity: <ul style="list-style-type: none"> ▪ Metal shields the food from microwave energy and produces uneven cooking. ▪ Also avoid metal skewers, thermometers or foil trays. ▪ Metal utensils can cause arcing, which can damage your microwave.
Metal decoration	Bowls, cups, serving plates and platters with metallic trim.
Aluminum foil	Avoid large sheets of aluminum foil because they hinder cooking and may cause harmful arcing. Use small pieces of foil to shield poultry legs and wings. Keep ALL aluminum foil at least 1" (25 mm) from the side walls of the appliance cavity and appliance door.
Wood	Wooden bowls and boards will dry out and may split or crack when you use them in the microwave. Baskets made of wood will react in the same way.
Tightly covered cookware	Let steam escape: <ul style="list-style-type: none"> ▪ Be sure to leave openings for steam to escape from covered cookware. ▪ Pierce plastic pouches of vegetables or other food items before cooking. ▪ Tightly closed pouches may explode.

¹ These marks are registered trademarks of their respective owners. All other trademarks are trademarks of BSH Home Appliances Corporation or its affiliated companies.

Ovenware	Examples
Brown paper	Avoid using brown paper bags. They absorb heat and can burn.
Flawed or chipped cooking utensils	Cracked, flawed or chipped utensils may break in the appliance.
Metal twist ties	Remove metal twist ties from plastic or paper bags. They become hot and could cause a fire.

Testing ovenware for microwave suitability

Perform the following test if you are unsure whether your ovenware is suitable for use in the microwave. Do not turn on the microwave unless there is food inside. This ovenware test is the only exception to this rule.

1. Heat the empty ovenware at maximum power for ½ to 1 minute.
2. Check the temperature occasionally during that time.
 - ✓ The ovenware should still be cold or warm to the touch.
 - ✓ The ovenware is unsuitable if it becomes hot or if sparks are generated.

7 Before using for the first time

Apply the initial configuration settings. Clean the appliance and the accessories.

7.1 Initial use

Implement the settings for initial use before using your appliance.

First read the information under Safety.

The appliance must be installed and connected.

After connecting to the power supply, the appliance shows the "Initialization" display.

The appliance shows the "Initialization" display when it is first switched on after being connected to the power supply, if the initial start-up has not been completed successfully or the appliance has been restored to the factory settings.

Implement the following settings:

- Setting the language
- Activating Home Connect®
- Set the temperature unit
- Set the weight unit
- Setting the time format
- Set the time

You can retroactively change all of the settings in the basic settings → *Page 37*.

Follow the instructions in the display. The display guides you through the initial settings.

Setting the language and implementing the remaining settings

1. Press .
- ✓ The display shows the preset language.
2. Use the control ring to select the required display language.
3. Press ✓ to confirm.
4. Press →.
5. Implement the remaining settings.
 - ✓ The display shows the appliance display that is selected in the basic settings → *Page 37* as the start screen.

Cleaning the accessories

- ▶ Before first use, clean the accessories thoroughly using hot soapy water and a soft cloth.



Heating up the appliance

1. Ensure that there is no leftover packaging in the oven cavity.
2. Remove any accessories from the oven cavity.
3. To eliminate the new-appliance smell, heat up the empty appliance with the door closed.

The ideal setting for heating is 230 °C for one hour without microwave output.
4. Clean the appliance interior.

8 Basic Operation

8.1 Switching on the appliance

1. To exit low power mode → *Page 17*, press  on the appliance's control ring or in the Home Connect® app.
 - ✓ The display shows the microwave mode with microwave setting and a symbol for the cooking time.
 - ✓ The appliance switches the interior lighting on.
 - ✓  lights up orange.
2. Set the microwave output and cooking time.

Tip: In the basic settings → *Page 37*, you can specify which appliance display appears on the display after the appliance is switched on and whether you want the interior lighting to switch on.

Note: If you do not implement any settings for an extended period, the display shows the appliance display that is selected in the basic settings → *Page 37* as the start screen, and then the low power mode display.

8.2 Opening the appliance door



WARNING

The inside of the appliance door becomes very hot during operation.

- ▶ During or after operation of the appliance, only touch the appliance door at the surface intended for this on the side.
- ▶ Always open the appliance door as far as it will go.

⚠ WARNING

Hot steam may escape when you open the appliance door. Steam may not be visible, depending on the temperature.

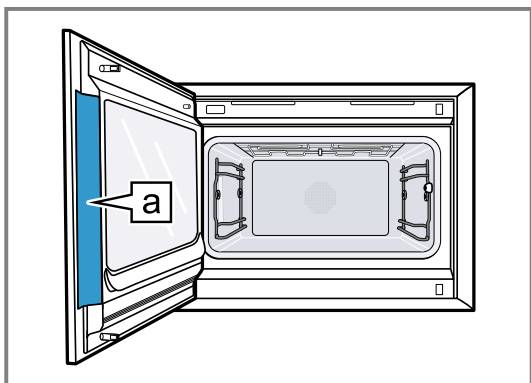

- ▶ Open the appliance door carefully.
 - ▶ Keep children away from the appliance.
1. Press .
 - ▶ If the "Door lock" function is activated in the basic settings → *Page 37*, move the slide control to the other end.
 - ✓ The appliance door opens automatically.
 2. Only touch the appliance door at the designated area  and open it fully.



Tip: In the control center, you can set that the appliance door opens automatically after the current cooking process.

→ *"Opening the appliance door automatically after the cooking process"*, *Page 21*

8.3 Changing the type of heating

1. If required, swipe from right to left to switch from the "Microwave" appliance display oven mode → *Page 23*.
2. Press the current symbol for the type of heating.
3. Use the control ring to select the required type of heating.
4. Press on the selected type of heating or , or wait a few seconds.
- ✓ The display shows the selected type of heating, the default temperature, and, for some types of heating, the preset cooking time.
- ✓ If you have previously used the type of heating, the display shows the last temperature that you used.
5. If required, change the temperature. → *Page 21*
6. If the display shows a notification window, follow the instructions in the notification window.
7. Press  to switch to the overview of oven mode.

If you do not use the appliance for an extended period, the display returns to the previously stored appliance display.
8. Press  to start the operation.

8.4 Changing the temperature

Note: You can change the temperature during operation.

Requirement: The type of heating is selected.

→ *"Changing the type of heating"*, *Page 21*

1. Press the temperature displayed.

2. Use the control ring to select the desired temperature.
- ✓ The display shows the temperatures that are available for the selected type of heating.
3. To change the previously stored appliance display, press the required temperature or .

If you do not use the appliance for an extended period, the display returns to the previously stored appliance display.
- ✓ The display shows the selected temperature.

Note: Once the operation has started, the display shows a progress bar below the selected temperature if the changed temperature is more than 20 °C higher than the previous temperature.

8.5 Displaying the current interior oven temperature

- ▶ Press and hold the set temperature.
- ✓ The display shows the current interior oven temperature.

Note: During continuous operation after heating up, slight temperature fluctuations are normal.

8.6 Opening the appliance door automatically after the cooking process



The "automatic door opening" function at the end of the cooking process is only valid for the current cooking process.

⚠ WARNING

The appliance and its parts that can be touched become hot during use.



- ▶ Young children under 8 years of age must be kept away from the appliance.
- ▶ Ensure that young children are not in the vicinity of the appliance when the appliance door opens automatically.

Note: Use the "automatic door opening" function at the end of the cooking process only if required to prevent the food from being overcooked or burning. In order to reduce the amount of moisture deposited on the unit fronts, open the appliance door fully after the cooking time has elapsed if possible.

1. Press .
2. Press .
- ✓ The display shows .
- ✓ The appliance opens the appliance door automatically after the current cooking process with a set cooking time end or set core temperature.

Note: The appliance door also opens when the child lock → *Page 29* is activated or the door lock → *Page 18* is activated.

8.7 Deactivating automatic appliance door opening

1. Press .
2. Press .
- ✓ The display shows .
- ✓ Automatic appliance door opening after the cooking process is deactivated.

8.8 Interrupting and continuing an operation

1. To interrupt the operation, press ■.
2. To continue the operation, press ▶.

8.9 Opening and closing the control center

1. Press ☰ to open the control center.
- ✓ The appliance shows a description above the functions currently active.
2. To activate or deactivate a function as required, press the symbol for the function.
3. Press < to close the control center.
- ✓ A pop-up message → *Page 17* tells you if a function has been activated.

8.10 Switching the interior lighting on or off

1. Press ☰.
2. Press ✨.

8.11 Switching off the appliance

- ▶ Press ⏻ on the control ring.
- ✓ The appliance switches to low power mode.

8.12 Switching on the appliance after automatic shut-off

Requirement: After prolonged operation, the automatic shut-off → *Page 17* switches off the appliance.

- ▶ Press ⏻ on the control ring.

8.13 Displaying information

- ▶ Press ⓘ.
- ✓ The appliance displays information about the selected function.
→ *"Additional information", Page 17*

8.14 Displaying appliance information

1. Swipe repeatedly from left to right until the display shows "Modes & Service".
- ✓ The display shows the available functions in a list menu.
2. Use the control ring to select the "Appliance information" function.
3. Press "Appliance information".
- ✓ The display shows the appliance information, e.g. the E-number and the serial number.
4. Press < to exit the display.

8.15 Using the quick guides

1. Select the "Modes & Service" appliance display.
→ *"Appliance displays", Page 14*
2. Use the control ring to select "Quick guide", then release the control ring.
3. Select the required quick guide and view it.

9 Microwave

You can use the microwave to cook, heat up or defrost food very quickly. The microwave can be used on its own or in combination with a type of heating.

9.1 Microwave-safe cookware and accessories

To heat food evenly and avoid damaging your appliance, it is important to use the right cookware and accessories.

Note: Read the manufacturer's instructions before using any cookware in the microwave. If in doubt, carry out a cookware test.

Microwave-safe

Cookware and accessories	Justification
Cookware made from heat-resistant, microwave-safe material: <ul style="list-style-type: none"> ▪ Glass ▪ Glass ceramic ▪ Porcelain ▪ Temperature-resistant plastic ▪ Fully glazed ceramic without cracks 	These materials allow microwaves to pass through. Microwaves do not damage heat-resistant cookware.

Cookware and accessories	Justification
Metal flatware	Note: You can use metal flatware, e.g. place a spoon in a glass, to prevent delayed boiling.

NOTICE

Metal touching the wall of the cooking compartment will cause sparks, which may damage the appliance or the inner door pane.

- ▶ Metal (e.g. a spoon in a glass) must be kept at least 2 cm from the cooking compartment walls and the inside of the door.

Not microwave-safe

Cookware and accessories	Justification
Metal cookware	Metal does not allow microwaves to pass through. The food hardly heats up.
Cookware with gold or silver decoration	Microwaves can damage gold and silver decoration. Tip: You can only use this kind of cookware if the manufacturer guarantees that it is microwave-safe.

9.2 Testing cookware for microwave suitability

Test cookware to see whether it is suitable for microwave use. Testing cookware is the only time the appliance should be operated in microwave mode without any food inside.

WARNING

The accessible parts of the appliance become hot during operation.

- ▶ Never touch these hot parts.
- ▶ Keep children away from the appliance.

1. Place the empty cookware in the cooking compartment.
2. Set the appliance to the maximum microwave output setting for 30 seconds to 1 minute.
3. Start the operation.
4. Check the cookware several times:
 - If the cookware is cold or warm to the touch, it is suitable for microwave use.
 - If the cookware becomes hot or sparks are created, stop the cookware test. The cookware is not microwave-safe.

9.3 Microwave power level

This is where you can find an overview of the different microwave output levels and recommendations on when to use them.

Microwave power level	Use
90 W	Defrost delicate foods.
180 W	Defrost foods.
360 W	Defrost foods or cook gently.
450 W	Cook foods or warm up gently.
600 W	Cook foods or warm up.
max.	Quickly heat liquids

Notes

- You can set the microwave output levels for a specific cooking time:

- The "Max." microwave output level for 30 minutes
- 90 W, 180 W, 360 W, 450 W and 600 W for 90 minutes
- The maximum setting is for heating liquids. To protect the appliance, it reduces the maximum microwave output level after some time. Full power is made available again after a cooling period. During operation, the display shows the current microwave output levels.

9.4 Setting the microwave

1. To set the microwave output level, turn the control ring or press the required microwave output level.
2. To switch to the "Microwave" appliance display, press <.
- ✓ The display shows the selected microwave output level.
3. If required, set the cooking time → *Page 27*.
4. If required, move the cooking time end → *Page 27* to a later time.
5. Press ▶.
- ✓ The operation begins. You can see the cooking time counting down.
- ✓ A signal tone sounds once the cooking time has elapsed. Press ✓ or open the appliance door to end the signal early.
- ✓ The operation has finished.

Notes

- If you open the appliance door during cooking, the microwave operation stops. To continue the operation, close the appliance door and press ▶. If you select the "On" setting in the basic settings for the "Microwave automatic resume" function, the appliance automatically continues operation.
- You can change the microwave output or temperature at any time. Press ▶ to start.

9.5 Interrupting and continuing microwave operation

- ▶ Press ■.
- ✓ The display shows the remaining cooking time and the selected microwave output level.









10 Oven

Your appliance has an oven mode.

10.1 Types of heating in oven mode

In oven mode, you can set different types of heating.

Symbols	Function/type of heating	Temperature/setting	Performance	Use
	Convection	86-445°F (30-230°C)		The heat arises from the back wall of the cooking compartment and is distributed quickly and evenly by the fan. For cooking on one or two levels with an ex-

Symbols	Function/type of heating	Temperature/setting	Performance	Use
				tremely short preheating time. For moist cakes, cookies, bakes. To reduce the cooking time, the microwave can be switched on.
	Broil + circulated air	86-445 °F (30-230 °C)		For au gratin dishes at the end of the cooking time at 445 °F (230 °C). For grilling vegetable skewers and shrimp skewers at 355 °F (180 °C). Extremely intensive heat from above, which is distributed quickly and evenly by the fan. Guarantees that a crust is formed with simultaneous all-round heating. For meat, poultry, fish, vegetable skewers. No preheating is required. To reduce the cooking time, the microwave can be switched on.
	Drying	86-176 °F (30-80 °C)		For drying thin slices of fruit or vegetables or herbs. Moisture is actively extracted from the cooking compartment.
	Low-temperature cooking	86-194 °F (30-90 °C)	90 W	Slow and gentle cooking of meat for a particularly tender result. Hot air is combined with a low microwave output in order to reduce the cooking time. Briefly sear meat before cooking.
	Dough proofing	86-122 °F (30-120 °C)		Optimal temperature range for proving dough batches and pieces of dough. For yeast dough and sourdough. The optimal temperature setting for yeast dough is 100 °F (38 °C).
	Keeping warm		50 W	Optimal microwave output for keeping food warm without it drying out.
	Defrosting		90-360 W	Optimal microwave output range for quickly and gently defrosting frozen food. Use 90 W for delicate foods.
	Warming up beverages		max.	Optimal microwave output for quickly heating liquids such as water and milk.
	Reheat meals		360-600 W Default power 360 W	Optimal microwave output range for heating up cooked meals, such as plated meals, bakes and soups.

10.2 Setting the type of heating and temperature

1. If required, swipe from right to left to switch from the "Microwave" appliance display oven mode → *Page 23*.
2. Press the current symbol for the type of heating.
3. Use the control ring to select the required type of heating.
4. Press on the selected type of heating or <, or wait a few seconds.
 - ✓ The display shows the selected type of heating, the default temperature, and, for some types of heating, the preset cooking time.
 - ✓ If you have previously used the type of heating, the display shows the last temperature that you used.
5. Set the required temperature if necessary.
 - ▶ Press the temperature displayed.
 - ▶ Use the control ring to select the desired temperature.
 - ▶ Press the desired temperature.
 If you do not use the appliance for an extended period, the display returns to the previously stored appliance display.
6. If the display shows a notification window, follow the instructions in the notification window.
7. If required, set the cooking time → *Page 27* or the core temperature → *Page 33*.
8. If required, move the cooking time end → *Page 27* to a later time.
9. To switch to the previous appliance display, press <. If you do not use the appliance for an extended period, the appliance returns to the previously stored appliance display.
10. Press ▶ to start the operation.

Interrupting and continuing an operation

1. To interrupt the operation, press ■.
2. To continue the operation, press ▶.

10.3 Add broiler

You can brown or gratinate your food using the broiler. The function "Add broiler" is available for the heating mode "Convection", when the temperature in the oven cavity is higher than 300°F (150°C). After around 4 minutes, the appliance switches the broiler off. If required, you can switch the broiler on again.

Turning on the broiler

NOTICE

Temperatures above 480 °F (250 °C) damage the core temperature probe.

- ▶ If you use the core temperature probe, never place the food on the top shelf level.
1. Use the control ring to select the "Convection" type of heating for the broiler.
 2. Press UUU.
- ✓ UUU lights up.
 - ✓ The appliance switches the grill off for approx. 3 minutes.

Deactivating the broiler

Requirement: UUU lights up orange.

- ▶ Press UUU.
- ✓ UUU lights up white.
- ✓ The broiler is deactivated.

11 Combi-operation

To reduce the cooking time and brown your meals, you can use the "Convection" or "Broil + circulated air" types of heating in combination with a microwave output.

Note: You can switch on microwave output settings up to 450 W.

The appliance reduces the maximum microwave output level after a longer period of operation. The maximum power output is made available again after a certain cooling period.

11.1 Setting combi-operation

1. Use the control ring to select the "Convection" or "Broil + circulated air" type of heating.

2. Press the type of heating or <.

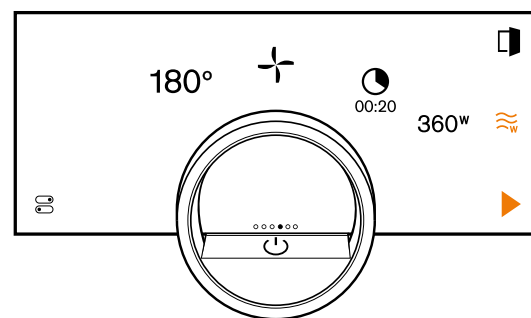

3. Add a microwave output level using ≡.
 - You can also add microwave operation while a heating process is active.
 - ✓ The display shows the preset microwave output level for the selected type of oven heating and a preset cooking time.
4. Press ☾.
 - ✓ The display shows h : min for hours and minutes.

5. Press on the desired value for the cooking time → *Page 27* and change the value using the control ring.
 - ▶ Turn the control ring slowly to change the value in smaller increments.
 - ▶ Turn the control ring quickly to change the value in greater increments.

The maximum possible cooking time depends on the type of heating.
6. Press < or press on the selected cooking time to switch to the previously stored appliance display. If you do not use the appliance for an extended period, the appliance saves the settings and the display returns to the previously stored appliance display.
7. Press on the required microwave output level and use the control ring to select the required microwave output.

If you do not use the appliance for an extended period, the display returns to the previously stored appliance display.
8. Set the cooking time → *Page 27* or the core temperature → *Page 33*.
9. Press ▶.
 - ✓ The operation begins. You can see the cooking time counting down.
 - ✓ A signal tone sounds once the cooking time has elapsed.
 - ✓ After a certain period of time without any further operation, the appliance ends the signal tone. You can set the duration of the signal tone in the basic settings → *Page 37*.
 - ✓ The operation has finished.
 - ✓ After around 1 minute, the appliance displays the previously set temperature, the type of heating, cooking time, microwave output and the time elapsed since the end of operation.
10. Press on the display to end the additional cooking time timer.

Note: If there is no further operation following the signal tone, the display shows the "Downtime timer" function with the + symbol. The display shows how much time has elapsed since the cooking time ended. After approx. 20 minutes without any further operation, the appliance switches to low power mode.

Changing settings

1. To change the type of heating, press on the type of heating and use the control ring to select a different type of heating.

If you select a type of heating for which combi-operation is not available, the appliance switches to oven mode.
2. To change the temperature, press on the temperature and use the control ring to select a different temperature.
3. To change the microwave output, press on the microwave output and use the control ring to select a different microwave output.
4. Change the cooking time → *Page 27*.
5. Press ▶ to start.

Interrupting and continuing an operation

1. To interrupt the operation, press ■.
 - ✓ The display shows the temperature, the type of heating, and the cooking time. In combi-operation, the display also shows the microwave output setting.
2. To continue the operation, press ▶.

Note: The fan may also continue to run when the door is open. This is normal.

11.2 Removing the microwave operation

Requirement: The "Convection" or "Broil + circulated air" type of heating is selected.

- ▶ Press ≈.
- You can also delete the microwave operation while a heating process is active.
- ✓ The display shows the type of heating and the preset cooking time for the type of heating.
- ✓ The display shows ≈.

11.3 Switching from combi-operation to microwave operation

1. To interrupt the operation, press ■.
2. Swipe repeatedly from left to right until the display shows the possible settings for microwave operation.

12 Timer functions

Your appliance has different timer functions, with which you can control its operation.

12.1 Overview of the timer functions

Use ● to select the different timer functions.

Timer function	Usage
●	Cooking time
→	Cooking time end

A cooking time or cooking time end can only be set in combination with a type of heating. The "Cooking time" and "Core temperature probe" functions are not available at the same time.

12.2 Call up the timer menu

- ▶ Press ●.
- ✓ Depending on the set type of heating, the display shows min and s for minutes and seconds, or h and min for hours and minutes.
- ✓ The display shows the display for the minutes enlarged in the 12 o'clock position.

12.3 Exiting the timer menu

- ▶ Press < or press on the selected cooking time to switch to the previously stored appliance display.
- ✓ The timer menu is closed.

12.4 Cooking time

When you set the cooking time for your food, the appliance automatically switches off after this time. The maximum possible cooking time depends on the set type of heating.

Depending on the type of heating, you can set a cooking time of 1 minute to 30 minutes, 90 minutes or 24 hours.

For the "Drying" type of heating, the maximum cooking time is 72 hours.

You can change the type of heating and temperature while the cooking time counts down.

Setting the cooking time

Requirement: No core temperature is set. You cannot use the "Cooking time" and "Core temperature probe" functions at the same time.

1. Place the food in the oven cavity.
2. Press **ⓘ**.
 - ✓ Depending on the type of heating, the display shows min : s for minutes and seconds or h : min for hours and minutes.
3. Press the required value and use the control ring to change the value.
 - ▶ Turn the control ring slowly to change the value in smaller increments.
 - ▶ Turn the control ring quickly to change the value in greater increments.

The maximum possible cooking time depends on the type of heating.

 - ✓ The appliance automatically calculates the time for the cooking time end.
4. Press < or press on the selected cooking time to switch to the previously stored appliance display. If you do not use the appliance for an extended period, the appliance saves the settings and the display returns to the previously stored appliance display.
 - ✓ If the appliance is in operation, the appliance shows the temperature or microwave output, the operating mode and the remaining cooking time.
 - ✓ For a cooking time of more than 59 minutes, the display uses the format h : min for hours and minutes.
 - ✓ For a cooking time of less than 60 minutes and depending on the type of heating set, the display uses the format min : s for minutes and seconds.
 - ✓ 3 minutes before the end of the cooking time, the display zooms in on the remaining cooking time.
 - ✓ After the cooking time has elapsed, the display shows 00:00 and a signal tone sounds.
5. Turn the control ring or open the appliance door. The appliance door opens automatically if you have activated this function.
 - "Opening the appliance door automatically after the cooking process", Page 21
 - ✓ The signal tone stops.

Note: If there is no further operation following the signal tone, the display shows the "Downtime timer" function with the + symbol. The display shows how much time has elapsed since the cooking time ended. After approx. 20 minutes without any further operation, the appliance switches to low power mode.

Changing the cooking time

For types of heating that require a cooking time, you can change the cooking time. For types of heating that do not require a cooking time, you can either change or delete the cooking time.

Requirement: You have set a type of heating.

1. Press **ⓘ**.
 - ✓ Depending on the type of heating, the display shows min : s for minutes and seconds or h : min for hours and minutes.
2. Press the required value and use C to delete the value, or use the control ring to change the value.
 - ▶ Turn the control ring slowly to change the value in smaller increments.
 - ▶ Turn the control ring quickly to change the value in greater increments.

For types of heating that require a cooking time, do not delete the cooking time but reset it to the preset cooking time using **↺**.

The maximum possible cooking time depends on the type of heating.

- ✓ The appliance automatically calculates the time for the cooking time end.
3. Press < or press on the selected cooking time to switch to the previously stored appliance display. If you do not use the appliance for an extended period, the display returns to the previously stored appliance display.
 - ✓ The display shows the temperature or microwave output, the operating mode, the remaining cooking time, and the cooking time end.

Deleting or resetting the cooking time

Note: For types of heating that require a cooking time, do not delete the cooking time.

For types of heating that do not require a cooking time, in the "Manual" (oven mode) appliance display, you can double-click on the cooking time in order to delete the cooking time without switching to the timer settings.

1. Press **ⓘ**.
 - ✓ Depending on the type of heating, the display shows min : s for minutes and seconds or h : min for hours and minutes.
2. Press the required value and use C to delete the value.
 - ✓ The display shows --:--.
3. Press < or press on the selected cooking time to switch to the previously stored appliance display. If you do not use the appliance for an extended period, the display returns to the previously stored appliance display.
 - ✓ The display does not show a cooking time.

12.5 Cooking time end

As soon as you set a cooking time, the display shows the cooking time end. You can delay the cooking time end by a maximum of 12 hours.



For example, if you set a cooking time of 90 minutes at 10 a.m., you can delay the end of the cooking time so that the cooking process ends at 11.30 p.m. at the latest.

For the "Drying" type of heating, the maximum cooking time is 72 hours.

Bear in mind that food which spoils easily should not be left in the appliance for too long.

Delaying the cooking time end

Requirement: No core temperature is set. You cannot use the "Cooking time" and "Core temperature probe" functions at the same time.



1. Place the food in the oven cavity.
2. Press .
- ✓ Depending on the type of heating, the display shows min : s for minutes and seconds or h : min for hours and minutes.
3. Set the cooking time. → *Page 27*
- ✓ The appliance automatically calculates the time for the cooking time end.
4. Press < or press on the selected cooking time to switch to the previously stored appliance display. If you do not use the appliance for an extended period, the display returns to the previously stored appliance display.
5. Press on the cooking time end.
6. Use the control ring to set the required cooking time end.
7. Press .
- ✓ The appliance switches to standby.
- ✓ The display shows the temperature or microwave output, the operating mode, and the cooking time end.
- ✓ If the end of cooking time is one or more days in the future, the display shows "+1d".
- ✓ The appliance starts at the calculated time and automatically switches off once the cooking time has elapsed.
- ✓ After the cooking time has elapsed, the display shows 00:00 and a signal tone sounds.
8. Turn the control ring or open the appliance door. The appliance door opens automatically if you have activated this function.
→ *"Opening the appliance door automatically after the cooking process", Page 21*
- ✓ The signal tone stops.

Note: If there is no further operation following the signal tone, the display shows the "Downtime timer" function with the + symbol. The display shows how much time has elapsed since the cooking time ended. After approx. 20 minutes without any further operation, the appliance switches to low power mode.

Resetting the delay of the cooking time end

Note: In the "Microwave" appliance display or in the "Manual" (oven mode) appliance display, double-click on the cooking time end in order to reset the delay of the cooking time end without switching to the timer settings.



Requirement: You have used the control ring to manually set the cooking time end.

1. Press .
2. To reset the delay of the cooking time, press .
- ✓ The appliance calculates the cooking time end based on the cooking time.
- ✓ The display shows the cooking time end.
3. Press < or press on the cooking time end to switch to the previously stored appliance display. If you do not use the appliance for an extended period, the display returns to the previously stored appliance display.

12.6 Count-up cooking timer

If no cooking time is set, the display shows the time that has elapsed since the start of the process. In the basic settings, you can switch the "Count-up cooking timer" function on or off.

Reset "Count-up cooking timer"

1. Press and hold .
2. Press .
- ✓ The "Count-up cooking timer" function is reset.

13 Manual door opening aid

13.1 Installing the manual door opening aid

1. Position the manual door opening aid on the side of the appliance where the appliance door opens.
 - ▶ Position the manual door opening aid on the top or bottom corner of the appliance door.

- ▶ Do not install the manual door opening aid on the surface intended for opening the appliance door.

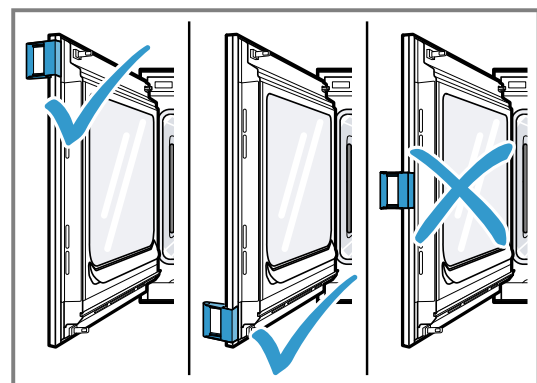

- You can also install the manual door opening aid if the appliance door is open.
2. To secure the manual door opening aid to the appliance door, position the manual door opening aid at

an angle between the appliance door and the appliance frame and push against the appliance door.

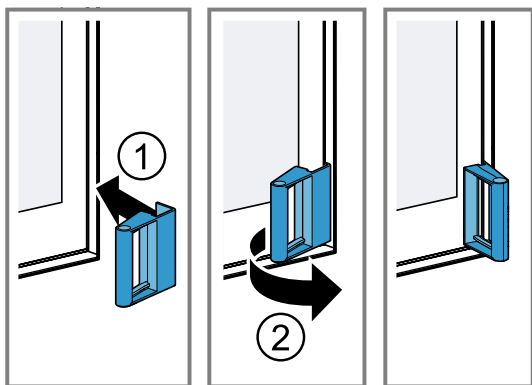

3. Make sure that the manual door opening aid lies flat against the appliance door and that there is no gap between the side edge of the appliance door and the manual door opening aid.

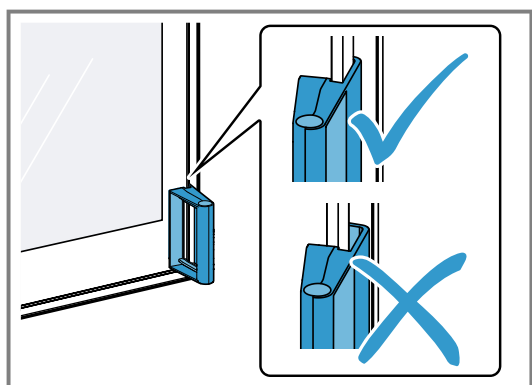

- ✓ You will hear a click.
- ✓ The manual door opening aid is installed.

13.2 Opening the appliance door using the manual door opening aid

- ▶ To open the appliance door using the manual door opening aid, pull the handle on the manual door opening aid.

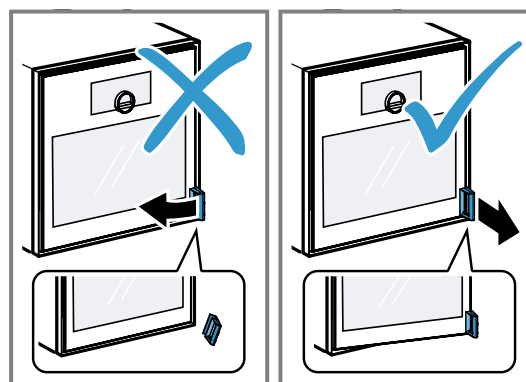

Note: Do not pull the handle to the side as this could cause the manual door opening aid to come loose from the appliance door. Pull the handle straight outwards.

13.3 Cleaning the manual door opening aid

1. Clean the manual door opening aid with hot soapy water and a soft cloth.
2. Dry the manual door opening aid with a soft cloth.

13.4 Removing the manual door opening aid

- ▶ Pull the handle of the manual door opening aid to the side opposite to the direction in which the appliance door opens.

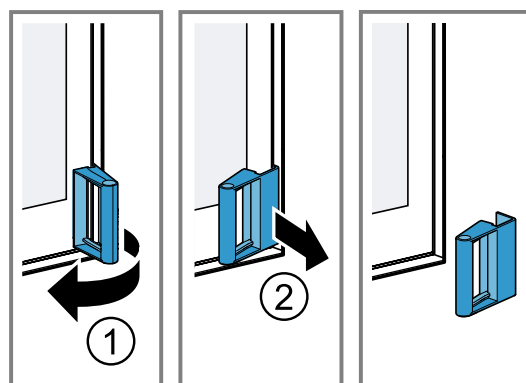

- ✓ The manual door opening aid is removed.

14 Child lock

Activate the "Child lock" function so that children cannot accidentally switch the appliance on or change the settings.



If the child lock is activated, operation via the display and the control ring is not possible.

If the child lock is activated and the power fails, the child lock can be deactivated when the power comes back on.

You can activate the child lock even during operation.

14.1 Activating the childproof lock

Requirement: In the basic settings → *Page 37*, the option "On" is set for the "Display child lock" function.

1. Press .
 2. Press .
- ✓ The display shows .
 - ✓ The "Child lock" function is activated.

14.2 Deactivating the childproof lock

1. Press and hold  for approximately 2 seconds.
 - ✓ The "Child lock" function is deactivated.
2. Set the appliance as normal.

15 Programs

The "Programs" appliance display includes the automatic programs and recommended settings.

15.1 Automatic programs

You can use the "Automatic programs" function to cook a wide variety of food. The appliance will choose the optimal setting for you.

In automatic programs, the appliance defines the optimal settings after you enter the weight and required cooking result, for example. The automatic programs are labeled with a checkmark in the overview list. You can find information about the accessories or shelf levels in the tip for the respective program.

Note: In the basic settings → *Page 37*, you can filter automatic programs, e.g. with the following filters "Vegetarian" or "No meat & poultry".

Information about the settings for the automatic programs

Observe the instructions for the settings of the automatic programs.

- The cooking result depends on the quality of the food and the size and type of cookware. For an optimal cooking result, only use food that is in good condition and meat that is chilled to refrigerator temperature. For frozen food, use food straight out of the freezer only.
- The food is divided into categories. One or more dishes are listed for each category. The display shows the last selected meal.
- For some dishes, the appliance asks you to enter, for example, the weight, the desired level of browning, the thickness of the food or the cooking level of the food.
- For some food, preheat the empty cooking compartment for an optimal cooking result. Place the food in the cooking compartment once the preheating is complete and a message appears in the display.
- The appliance displays the selected settings next time as a suggestion.
- For some programs, you need the core temperature probe. Use the core temperature probe → *Page 33* for these programs.
- To achieve good results, the cooking compartment must not be too hot for the type of food you have selected. If the cooking compartment is too hot, the display shows a corresponding notification. Allow the appliance to cool and then try again.

Selecting an automatic program

1. Swipe repeatedly from right to left until the display shows "Programs".
 - ✓ The display shows the first program in the "Vegetables" category or the last set automatic program.
 - ✓ The display shows the preselected values for the program or the last set values.
 - ✓ The display shows a tip and symbols for the Favorites → *Page 32* category and for the program start.
2. Use the control ring to select the required meal, and press on the required meal.
 - ✓ The display shows the name of the selected dish and the corresponding values.

Changing category

1. Press the symbol for the category.
 - ✓ The display shows the available categories in the ring menu.
2. Select the required category with the control ring.
3. Press < or press the category in order to confirm the selection.
 - ✓ The display shows the first dish in the selected category and the corresponding values.

Changing the program

1. Press on the name of a dish or navigate through the list of dishes in the menu with the control ring.
2. Press the required dish.
 - ✓ The display shows the name of the selected dish and the corresponding settings.
3. Press the setting.
4. Use the control ring to change the setting and press on the required setting.
 - Not all settings can be changed.
 - You cannot change the type of heating.
5. Press <.
 - ✓ The display shows the name of the selected dish and the corresponding settings.
6. Press .
 - ✓ The display shows information about the accessories and preparation.
7. Follow the information on the display.

Starting the automatic program

- ▶ Press .
- ✓ Once the cooking time has elapsed, a signal tone sounds.
- ✓ The appliance stops heating.

Note: If you open the appliance door during an automatic program, this affects the cooking result. Do not open the appliance door, or only open it briefly. The appliance interrupts the automatic program and continues to run when you close the appliance door.

Extending the cooking time

If you are still not satisfied with the cooking result, you can increase the cooking time again.

1. Press 00.00.
2. Select the required cooking time.
3. Press ✓ to confirm.

Canceling the automatic program

Note: Once you have started the automatic program, you can no longer change the settings.

- ▶ Press ■.
- ✓ The appliance ends the automatic program.

Saving a program as a favorite

You can save a program as a favorite at the start or end of an automatic program.

1. Press □.
 - ✓ The display shows the "Favorites" appliance display.
 2. Press $_/_$.
 3. Use the keyboard to enter a name.
 4. Press ✓.
- You can only change the settings for a saved favorite via the Home Connect® app.

15.2 Recommended settings

With recommended settings, the appliance specifies the optimal type of heating.

The recommended settings are not labeled with a checkmark in the overview list.

If a weight is specified in the tip, the recommended temperature and the cooking time relate to this weight specification. You can adapt the temperature and cooking time within the available ranges.

You can find information about the accessories or shelf levels in the tip for the respective program.

Information on the recommended settings

Observe the information on the recommended settings.

- The cooking result depends on the quality of the food and the size and type of cookware. For an optimal cooking result, only use food that is in good condition and meat that is chilled to refrigerator temperature. For frozen food, use food straight out of the freezer only.
- The food is divided into categories. One or more dishes are listed for each category. The display shows the last selected meal.
- With the recommended settings, the appliance specifies the type of heating.
- You can change the temperature and the cooking time in the specified areas.
- For some food, preheat the empty cooking compartment for an optimal cooking result. Place the food in the cooking compartment once the preheating is complete and a message appears in the display.
- The appliance displays the selected settings next time as a suggestion.
- To achieve good results, the cooking compartment must not be too hot for the type of food you have selected. If the cooking compartment is too hot, the display shows a corresponding notification. Allow the appliance to cool and then try again.

Selecting a recommended setting

1. Swipe repeatedly from right to left until the display shows "Programs".
 - ✓ The display shows the first program in the "Vegetables" category or the last set automatic program.
 - ✓ The display shows the preselected values for the program or the last set values.
 - ✓ The display shows a tip and symbols for the Favorites → *Page 32* category and for the program start.
2. Use the control ring to select the required meal, and press on the required meal.
 - ✓ The display shows the name of the selected dish and the corresponding values.

Changing category

1. Press the symbol for the category.
 - ✓ The display shows the available categories in the ring menu.
2. Select the required category with the control ring.
3. Press < or press the category in order to confirm the selection.
 - ✓ The display shows the first dish in the selected category and the corresponding values.

Changing the program

1. Press on the name of a dish or navigate through the list of dishes in the menu with the control ring.
2. Press the required dish.
 - ✓ The display shows the name of the selected dish and the corresponding settings.
3. Press the setting.
4. Use the control ring to change the setting and press on the required setting.
 - Not all settings can be changed.
 - You cannot change the type of heating.
5. Press <.
 - ✓ The display shows the name of the selected dish and the corresponding settings.
6. Press □.
 - ✓ The display shows information about the accessories and preparation.
7. Follow the information on the display.

Starting a recommended setting

- ▶ Press ▶.
- ✓ Once the cooking time has elapsed, a signal tone sounds.
- ✓ The appliance stops heating.

Note: If you open the appliance door when a recommended setting is running, this affects the cooking result. Do not open the appliance door, or only open it briefly. The appliance interrupts the recommended setting and continues to run when you close the appliance door.

Extending the cooking time

If you are still not satisfied with the cooking result, you can increase the cooking time again.

1. Press 00.00.
2. Select the required cooking time.
3. Press ✓ to confirm.

Changing a recommended setting

Note: Once you have started the recommended setting, you can change the settings.

1. Press on the recommended setting.
2. Change the desired settings.

Saving a program as a favorite

You can save a program as a favorite at the start or end of a recommended setting.

Requirements

- The temperature and type of heating are set.
 - The cooking time or core temperature is set.
1. Press \square .
 - ✓ The display shows the "Favorites" appliance display.
 2. Press $_/_$.
 3. Use the keyboard to enter a name.
 4. Press \checkmark .

You can only change the settings for a saved "Favorites" via the Home Connect® app.

16 Favorites

In the "Favorites" appliance display, you can save preferred automatic programs, recommended settings or combinations of type of heating, temperature, core temperature or cooking time. The appliance adopts the selected settings, such as microwave output, temperature, cooking time, weight or level of browning for the favorites.

You can individually select the names for the favorites. You can use the Home Connect® app to change the saved settings for the favorite or the order of the favorites.

After starting the favorite, you can change the settings.
→ "Changing a favorite", Page 32

16.1 Creating the first favorites

Notes

- You can save a food as a favorite at the beginning or end of an automatic program or a setting recommendation.
- You can save a favorite in the "Manual operation" appliance display. As soon as you have selected the settings for the temperature, the type of heating, the cooking time or the microwave power setting, the display shows \square .

Requirement: The settings for the favorites are selected or a heating process ends.

1. Press \square .
- ✓ The display shows the "Favorites" appliance display.
2. Press $_/_$.
3. Use the keyboard to enter a name.
4. Press \checkmark .

16.2 Selecting a favorite

1. Swipe repeatedly from right to left until the display shows "Favorites".
→ "Appliance displays", Page 14
2. Use the control ring to select the desired favorite.
3. Press the favorite.

16.3 Renaming a favorite

Requirement: The favorite has been selected.

→ "Selecting a favorite", Page 32

1. Press $_/_$.
2. Enter the name for the favorite.
3. Press \checkmark to confirm.

16.4 Starting a favorite

Requirement: The favorite has been selected.

→ "Selecting a favorite", Page 32

- ▶ Press \blacktriangleright to start.

16.5 Changing a favorite

The availability of settings depends on the favorite selected.

Requirements

- The favorite has been selected.
→ "Selecting a favorite", Page 32
 - The favorite is stopped.
1. Change the selected settings, e.g. the temperature, the type of heating, or the cooking time.
The "Add broiler" function is unavailable.
The "Automatic door opening at end of process" function is available.
If you have saved an automatic program as a favorite, you can only change certain settings, e.g. the weight, the required degree of browning, the thickness of the food or the cooking level of the food.
If you have saved a recommended setting as a favorite, you can change the settings on the appliance as soon as the favorite is started. You can only save the changed settings via the Home Connect® app.
As soon as the favorite is stopped or has finished, the Home Connect® app asks if you would like to save the settings in the favorite.
 2. Press \checkmark .
 3. Press \blacktriangleright to start.
 - ✓ The operation starts with the changed settings.

Note: The appliance does not save the changed settings in the selected favorite. If you select the favorite again, the settings match the settings when the favorite was created.

You can use the Home Connect® app to change the settings for the favorites.

16.6 Deleting a favorite

Requirement: The favorite has been selected.

→ "Selecting a favorite", Page 32

1. Press \boxtimes .
2. Press \checkmark to confirm.

17 Core temperature sensor

The core temperature probe makes it possible to cook with exact precision. The core temperature probe measures the temperature at 3 measuring points inside the food. When the required core temperature is reached, the appliance automatically switches off, ensuring that all food is cooked perfectly.

⚠ WARNING

The oven cavity and the core temperature probe become very hot.

- ▶ Use oven gloves when inserting and removing the core temperature probe.

NOTICE

Temperatures above 480°F (250°C) damage the core temperature probe.

- ▶ Only use the core temperature probe in your appliance at a maximum temperature of 445°F (230°C).
- ▶ Do not use the core temperature probe with the "Broil" type of heating.
- ▶ Before using the "Broil" type of heating, remove the core temperature probe from the cooking compartment.
- ▶ When using the core temperature probe with the "Broil + circulated air" type of heating, set the temperature to a maximum of 480°F (250°C).

⚠ WARNING

An incorrect core temperature probe may damage the insulation.

- ▶ Only use the core temperature probe that is suitable for this appliance.

NOTICE

Aggressive cleaning agents may damage the core temperature probe.

- ▶ Do not clean the core temperature probe in the dishwasher.

⚠ WARNING

The core temperature probe is sharp.

- ▶ Handle the core temperature probe with care.

Only use the core temperature probe that is suitable for this appliance. The core temperature probe → *Page 18* is available as a spare part from customer service or the online shop. You can also use the core temperature probe for the Gaggenau oven or the combi-steam oven in the same series.

If you use the core temperature probe, never place the food on the top shelf level.

After use, always remove the core temperature probe from the cooking compartment. Never store the core temperature probe in the cooking compartment.

After each use, clean the core temperature probe with a damp cloth.

The measurable range is 60-212 °F (15 °C to 100 °C). Outside of the measurable range, the display shows "<60 F (15 °C)" or ">212 F (100 °C)" for the current core temperature.

If you leave food in the cooking compartment for some time after cooking, the core temperature will continue to rise somewhat due to the residual heat in the cooking compartment.

17.1 Inserting the core temperature probe into the food

1. Insert the core temperature probe fully into the food.
2. Do not insert the core temperature probe into the fat.
3. Ensure that the core temperature probe is not touching any cookware or any bones.
4. Place the food in the oven cavity.

Inserting the core temperature probe into meat

1. Insert the core temperature probe at the thickest point on the side as far as it will go into the meat.

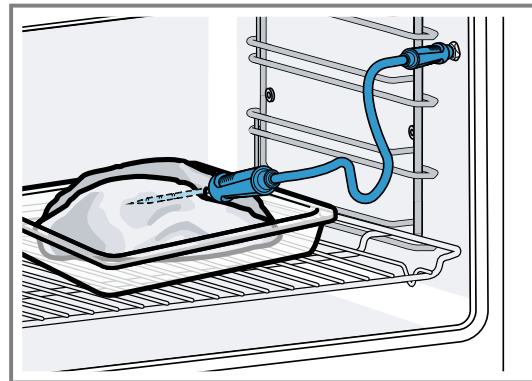

2. If there is more than one piece of meat, insert the core temperature probe into the middle of the thickest piece.

Inserting the core temperature probe into poultry

1. Insert the core temperature probe as far as it will go into the thickest point in the breast.

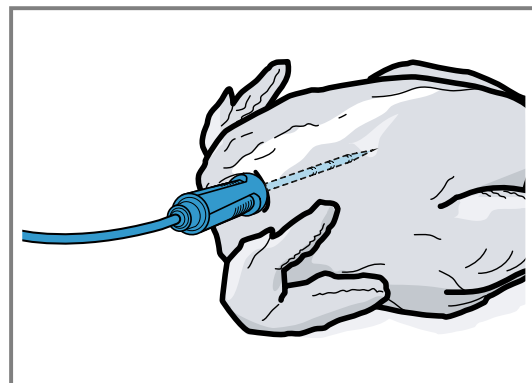

- Depending on its composition, insert the core temperature probe into the poultry crossways or lengthways.

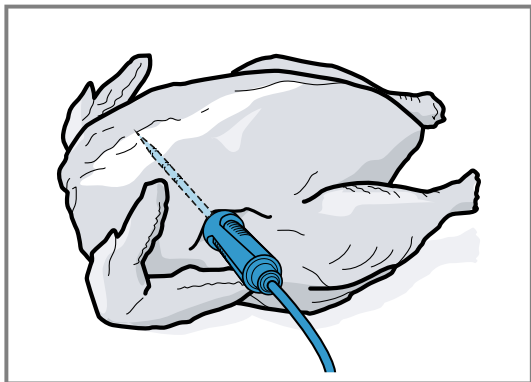

- With poultry, ensure that the tip of the core temperature probe does not protrude into the cavity in the middle of the bird.

Inserting the core temperature probe into fish

- Insert the core temperature probe behind the head as far as it will go towards the spine.

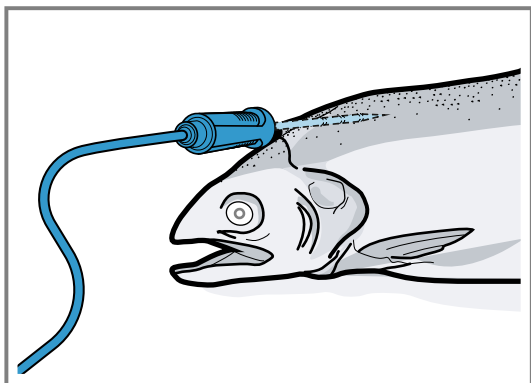

- Place the whole fish onto the wire rack and prop it up in the swimming position using half a potato.

17.2 Turning the food

- Do not pull out the core temperature probe when turning the food.
- Turn the food.
- Once you have turned the food, check that the core temperature probe is correctly positioned in the food.

17.3 Setting the core temperature probe

NOTICE

The heat of the grill heating element may damage the core temperature probe.

- Ensure that the distance between the grill heating element and the core temperature probe and the cable of the core temperature probe is a few centimeters. In doing so, ensure that the meat can expand during the cooking process.

You may damage the cable of the core temperature probe with the appliance door.

- Do not trap the cable of the core temperature probe in the appliance door.

Requirement: A cooking time end is not set. The cooking time end and core temperature probe functions are not available at the same time.

- Slide the food into the oven cavity with the core temperature probe inserted.
- Insert the core temperature probe into the socket in the oven cavity.
- Close the appliance door.
- The display shows the current interior oven temperature and the symbol for the core temperature probe.
- Select the required type of heating and interior oven temperature using the control ring.
- Press .
- Use the control ring to select the required core temperature → *Page 35*.
 - Ensure that the set core temperature is higher than the current core temperature.
 You can change the set core temperature at any time.
- The set core temperature can be cleared and reset as needed using C or the control ring.
- Press < or press the set core temperature.
- Press .
- The appliance heats up using the set type of heating.
- Once you have set the core temperature, the display shows the type of heating and the current core temperature.
- Once you have set the core temperature, the display shows the type of heating and switches between displaying the estimated time → *Page 35* until the core temperature is reached and the current and set core temperature.
- If the current core temperature is 9°F (5°C) below the set core temperature, the display shows the current and set core temperature as enlarged.
- Once the core temperature for the food has been reached, the display shows the required core temperature alongside the set core temperature and a signal sounds.
- The appliance ends the cooking process automatically.

Note: If you do not continue to operate the appliance after the signal tone, the display shows how much time has elapsed since the food reached the core temperature.

Once you start operating the appliance again, the appliance clears the time display. After around 20 minutes without any further operation, the appliance switches to low power mode.

17.4 Deleting the set core temperature

- In the "Microwave" or "Manual" (oven mode) appliance display, double-click on the temperature. → *"Appliance displays", Page 14*
- The display shows the current core temperature.

17.5 Changing the set core temperature

- Press .
- Change the set core temperature using the control ring.
 - Once the display shows the set core temperature enlarged in the 12 o'clock position, you can change the set core temperature directly using the control ring.

17.6 Core temperature guideline values

The following overview provides you with guideline values for the core temperature. The guideline values depend on the quality and composition of the food.

Only use fresh food that has not been frozen. For hygiene reasons, ensure that critical foods such as fish and game reach a core temperature of at least 140-160 °F (62-70 °C) and poultry and minced meat 180-195 °F (80-90 °C).

Food	Core temperature guideline value in °F (°C)
Beef	
Sirloin, fillet of beef, entrecôte, roast beef, rare	116-131 (47-55)
Sirloin, fillet of beef, entrecôte, roast beef, medium rare	133-145 (56-63)
Sirloin, fillet of beef, entrecôte, roast beef, medium	147-158 (64-70)
Sirloin, fillet of beef, entrecôte, roast beef, well done	160-167 (71-75)
Pork	
Joint of pork	167-176 (75-80)
Loin of pork, medium rare	149-158 (65-70)
Loin of pork, medium	160-167 (71-75)
Pork loin, well done	169-176 (76-80)
Meatloaf	185 (85)
Fillet of pork, medium rare	149-158 (65-70)
Fillet of pork, medium	160-167 (71-75)
Veal	
Joint of veal, well done	167-176 (75-80)
Breast of veal, stuffed, well done	167-176 (75-80)
Saddle of veal, medium	147-158 (64-70)
Saddle of veal, well done	160-167 (71-75)
Fillet of veal, rare	120-131 (50-55)
Fillet of veal, medium rare	133-145 (56-63)
Fillet of veal, medium	147-158 (64-70)
Fillet of veal, well done	160-167 (71-75)
Game	
Saddle of venison	140-158 (60-70)
Leg of venison	158-167 (70-75)
Venison loin steaks	149-158 (65-70)
Saddle of hare, saddle of rabbit	149-158 (65-70)
Poultry	
Chicken	194 (90)

Food	Core temperature guideline value in °F (°C)
Guinea fowl	176-185 (80-85)
Goose, turkey, duck	185-194 (85-90)
Duck breast, medium rare	131-140 (55-60)
Duck breast, medium	141-158 (61-70)
Duck breast, well done	160-176 (71-80)
Ostrich steak	140-149 (60-65)
Lamb	
Leg of lamb, medium	149-156 (65-69)
Leg of lamb, well done	158-176 (70-80)
Saddle of lamb, medium rare	131-140 (55-60)
Saddle of lamb, medium	141-147 (61-64)
Saddle of lamb, well done	149-167 (65-75)
Mutton	
Leg of mutton, medium rare	158-176 (70-75)
Leg of mutton, medium	169-176 (76-80)
Leg of mutton, well done	178-185 (81-85)
Saddle of mutton, medium	158-176 (70-75)
Saddle of mutton, well done	169-176 (76-80)
Fish	
Fillet, whole, medium	136-147 (58-64)
Fillet, whole, well done	149-154 (65-68)
Terrine	144-149 (62-65)
Other	
Bread	205 (96)
Pâté	162-167 (72-75)
Terrine	158-176 (70-75)
Foie gras	113-140 (45-60)
Reheating food	167 (75)

17.7 Estimated cooking time

After preheating, if the appliance has a temperature setting above 250 °F (120 °C) and the core temperature probe is inserted, the display shows an estimated cooking time a few minutes into the cooking time. The appliance continuously updates the estimated cooking time. The estimated cooking time is only available if you connect your appliance to the Home Connect® app.

The longer the cooking process lasts, the more precise the estimated cooking time becomes. Do not open the appliance door; this distorts the estimated cooking time. The display shows the estimated cooking time in manual operation and in the automatic program.

To display the current core temperature, press on the set core temperature.

18 Home Connect®

This appliance is network-capable. Connecting your appliance to a mobile device lets you control its functions

via the Home Connect® app, adjust its basic settings and monitor its operating status.

The Home Connect® services are not available in every country. The availability of the Home Connect® function depends on the availability of the Home Connect® services in your country. You can find information on this at: www.home-connect.com.

The Home Connect® app guides you through the entire registration process. Follow the instructions, noting the information in the Home Connect® app.

Notes

- Note the safety information in this instruction manual and ensure that it is also observed when operating the appliance using the Home Connect® app.
- Operating the appliance on the appliance itself always takes priority. It is not possible to operate the appliance using the Home Connect® app during this time.
- In networked standby mode, the appliance requires a maximum of 2 watts.

18.1 Setting up Home Connect®

Requirements

- The appliance is connected to the power supply and is switched on.
- You have a mobile device with a current version of the iOS or Android operating system, e.g. a smartphone.
- The appliance receives signals from the WLAN home network (Wi-Fi) at its installation location.
- The mobile device and the appliance are within range of your home network's Wi-Fi signal.

1. Scan the following QR code.



You can install the Home Connect® app and connect your appliance via the QR code.

2. Follow the instructions in the Home Connect® app.

18.2 Home Connect® settings

You can adjust the home network settings in your appliance's basic settings.

Which settings the display shows will depend on whether Home Connect® has been set up and whether the appliance is connected to your home network.

You can switch the network connection on or off as required. The network information is retained after the appliance is switched off. After switching on the appliance, wait for a few seconds until it reconnects to the home network.

The display uses different symbols to show the connection strength to the router.

Note: In networked standby mode, the appliance requires a maximum of 2 W.

You can use the Home Connect® app to access the appliance's functions. If you select the "Off (monitoring only)" setting in the basic settings → *Page 37* for "Re-

mote start", the Home Connect® app only shows the appliance's operating status and you can configure the settings.

If you select the "Permanent" setting in the basic settings → *Page 37* for "Remote start", you can start and operate your appliance at any time without any prior approval on the appliance.

If you select the "Manual" setting in the basic settings → *Page 37* for "Remote start", the appliance requires approval in the control center in order to start a function. In the basic settings → *Page 37*, you can use "Network information" to display the network information. In the basic settings → *Page 37*, you can use "Network credentials reset" to delete all network access data from the appliance at any time.

18.3 Starting functions with the Home Connect® app via manual "Remote start"



You can use the Home Connect® app to set the appliance remotely via the "Remote start" function. If you select the "Manual" setting in the basic settings for "Remote start", the appliance requires approval in the control center in order to start a function.

⚠ WARNING

Combustible objects that are left in the cooking compartment may catch fire.

- ▶ Never store combustible objects in the cooking compartment.
- ▶ If smoke is emitted, the appliance must be switched off or the fuse must be switched off and the door must be held closed in order to stifle any flames.

Requirements

- The appliance is connected to the home network and to the Home Connect® app.
 - To start a function, the "Manual" setting is selected in the basic settings for "Remote start".
1. To activate manual remote start, press  and then .
 2. Configure a setting in the Home Connect® app and send it to the appliance.
 3. Start a function.

Note: If you open the appliance door more than 15 minutes after activating remote start or after the operation ends, the appliance deactivates the manual remote start.

24 hours after activating remote start, the appliance deactivates the manual remote start.

18.4 Starting functions with the Home Connect® app via permanently activated "Remote start"

You can use the Home Connect® app to set and start the appliance remotely via the "Remote start" function. If you select the "Permanent" setting in the basic settings for "Remote start", the appliance does not require approval in the control center in order to start a function.

⚠ WARNING

Combustible objects that are left in the cooking compartment may catch fire.

- ▶ Never store combustible objects in the cooking compartment.

- ▶ If smoke is emitted, the appliance must be switched off or the fuse must be switched off and the door must be held closed in order to stifle any flames.

Requirements

- The appliance is connected to the home network and to the Home Connect® app.
 - To start a function, the "Permanent" setting is selected in the basic settings for "Remote start".
1. Configure a setting in the Home Connect® app and send it to the appliance.
 2. Start a function.

18.5 Using the Home Connect® app to change settings

You can use the Home Connect® app to set the appliance remotely.

WARNING

Combustible objects that are left in the cooking compartment may catch fire.



- ▶ Never store combustible objects in the cooking compartment.
- ▶ If smoke is emitted, the appliance must be switched off or the fuse must be switched off and the door must be held closed in order to stifle any flames.

Requirement: The appliance is connected to the home network and to the Home Connect® app.

- ▶ Configure a setting in the Home Connect® app and send it to the appliance.

18.6 Switching the Wi-Fi on or off

Requirement: The "On" and "Off" settings are only available if a connection to the Home Connect® server has been established.

1. Press  in the status line.
2. Press  in the control center.
3. Press the desired setting.
4. If required, use < to switch to "Settings".

18.7 Software update

Your appliance's software can be updated using the software update function, e.g. for the purposes of optimization, troubleshooting or security updates.

To do this, you must be a registered Home Connect® user, have installed the app on your mobile device and be connected to the Home Connect® server.

As soon as a software update is available, you will be informed via the Home Connect® app and will be able to start the software update via the app. Once the update has been successfully downloaded, you can start installing it via the Home Connect® app if you are in your home network (Wi-Fi). The Home Connect® app informs you once the installation is successful. You can find the current software version in the Home Connect® app under the appliance information for the appliance.

Notes

- The software update consists of two steps.
 - The first step is the download.
 - The second step is the installation on your appliance.
- You can continue to use your appliance as normal while updates are downloading. Depending on your personal settings in the app, software updates can also be set to download automatically.
- Installation takes a few minutes. You cannot use your appliance during installation.
- We recommend that you install security updates as soon as possible.

18.8 Data Protection

Please read this information on data protection.

The first time your appliance is registered on a home network connected to the Internet, your appliance transmits the following types of data to the Home Connect® server (initial registration):

- Unique appliance identification (consisting of appliance codes as well as the MAC address of the installed Wi-Fi communication module).
- Security certificate of the Wi-Fi communication module (to ensure a secure data connection).
- The current software and hardware version of your home appliance.
- Status of any previous reset to factory settings.

This initial registration prepares the Home Connect® functions for use and is only required when you want to use the Home Connect® functions for the first time.



Note: Please note that the Home Connect® functions can only be used in conjunction with the Home Connect® app. Information on data protection can be retrieved in the Home Connect® app.

19 Basic settings

You can configure the basic settings for your appliance to meet your needs.

19.1 Overview of the basic settings

Here you can find an overview of the basic settings and factory settings. The basic settings depend on the features of your appliance.

Symbol	Basic setting	Setting	Selection	Use
	Wi-Fi	Wi-Fi	<ul style="list-style-type: none"> ▪ On ▪ Off¹ 	<p>Switching the Wi-Fi on or off</p> <p>Note: The On and Off settings are only available if a connection to the Home Connect® server has been established.</p> <p>All settings are retained after the appliance is switched off. Switch on the Wi-Fi in order to allow the appliance to be controlled via the app and to use additional appliance functions.</p>
		Home Connect® assistant	<ul style="list-style-type: none"> ▪ During the initial connection to the Home Connect® app: "Start" ▪ If you have already connected successfully to the Home Connect® app: "Connect now" 	Setting up Home Connect® → <i>Page 35</i>
		Remote start	<ul style="list-style-type: none"> ▪ Off (monitoring only) ▪ Manual¹ ▪ Permanent <p>Note: The settings are only available if you have selected the "On" setting for Wi-Fi.</p>	Setting "Remote start" → <i>"Starting functions with the Home Connect® app via manual 'Remote start'", Page 36</i>
		Network information	<ul style="list-style-type: none"> ▪ MAC address ▪ Wi-Fi SSID ▪ IPv4 address ▪ IPv6 address <p>Note: The settings are only available if you have selected the "On" setting for Wi-Fi.</p>	Displaying "Network information"
		Network credentials reset	<ul style="list-style-type: none"> ▪ Confirm <p>The connections are reset. The appliance deletes saved network access data.</p> <p>Note: The settings are only available if you have selected the "On" setting for Wi-Fi.</p>	Reset the network access data
	Display	Brightness	<ul style="list-style-type: none"> ▪ 1 ▪ 2 ▪ 3 ▪ 4¹ ▪ 5 ▪ 6 	Sets the brightness in increments





¹ Factory setting (may vary according to model)

Symbol	Basic setting	Setting	Selection	Use
		Distant view	<ul style="list-style-type: none"> ▪ "On"¹: The display shows less content if you are at a greater distance. ▪ "Off": The display always shows the same content. 	Switch the remote view on or off
		Screen in off-mode	<ul style="list-style-type: none"> ▪ GAGGENAU logo"displayed on approach"¹ ▪ None 	Sets the low power mode display → <i>Page 17</i>
		Ring behavior	<ul style="list-style-type: none"> ▪ "Standard": Press the required function and use the control ring to change the function ▪ "Quick selection"¹: Use the control ring to change the function located above the control ring 	Set the control ring behavior
		Display child lock	<ul style="list-style-type: none"> ▪ "On"¹: The symbol for the "Display child lock" function is only visible in the status line if the "Display child lock" function is active. Control ring and touch fields are locked. ▪ "Off": The "Display child lock" function cannot be activated. 	Displays or hides the symbol for the child lock → <i>Page 29</i> in the control center
		Door lock	<ul style="list-style-type: none"> ▪ Activated ▪ Off¹ 	Activates or deactivates the door lock Note: The door lock → <i>Page 18</i> prevents the appliance door from being opened accidentally. This is particularly useful when installing the appliance under the countertop.
		Display alignment	<ul style="list-style-type: none"> ▪ Vertical¹ ▪ Horizontal 	Aligns the display horizontally or vertically depending on the appliance's installation position or the user's body size
	Sounds	Switch-on/switch-off sounds	<ul style="list-style-type: none"> ▪ Quiet ▪ Standard¹ ▪ Loud 	Set the volume of the on/off tones
		Notification sounds	<ul style="list-style-type: none"> ▪ Off ▪ Quiet ▪ Standard¹ ▪ Loud 	Set the volume of the notification tones

¹ Factory setting (may vary according to model)

Symbol	Basic setting	Setting	Selection	Use
				Note: The notification tones for the warnings and error messages always remain switched on.
		Process sounds	Volume <ul style="list-style-type: none"> ▪ Off ▪ Quiet ▪ Standard ¹ ▪ Loud "Repetitions": <ul style="list-style-type: none"> ▪ 1x ▪ "10 s": The appliance emits the signal tone repeatedly for 10 seconds. ▪ "30 s" ¹: The appliance emits the signal tone repeatedly for 30 seconds. ▪ "3 min": The appliance emits the signal tone repeatedly for 3 minutes. "Preheating signal": <ul style="list-style-type: none"> ▪ "On" ¹ ▪ Off 	<ul style="list-style-type: none"> ▪ Set the volume of the process tones ▪ Sets the desired maximum duration of the process tones ▪ Activates or deactivates the process tone following pre-heating
		Visual feedback	<ul style="list-style-type: none"> ▪ On ▪ Off ¹ 	Switches the pulsating light for program end, notifications or error messages on or off
		Volume reduction	<ul style="list-style-type: none"> ▪ "On": Lowers the volume for all tones to a certain volume level in a defined period ▪ "Reduced": Lowers the volume for all tones to the "Quiet" volume level in a defined period and switches off the tones for cleaning ▪ "Off" ¹: Switches off all tones in a defined period Start time <ul style="list-style-type: none"> ▪ "22h" ¹ End time <ul style="list-style-type: none"> ▪ "7h" ¹ 	Sets the lowering of the volume Note: The signal tones for warnings, error messages, and switching on and switching off always remain switched on.
	Interior lighting	Brightness	<ul style="list-style-type: none"> ▪ Dark ▪ Standard ¹ ▪ Bright 	Sets the brightness of the interior lighting
		Activation	<ul style="list-style-type: none"> ▪ Automatic ¹ ▪ Manual 	Switches the interior lighting on automatically or manually
		Light interaction	<ul style="list-style-type: none"> ▪ On ¹ ▪ Off 	Sets the light interaction

¹ Factory setting (may vary according to model)

Symbol	Basic setting	Setting	Selection	Use
				Note: If you are outside of the range that the appliance recognizes, the appliance reduces the interior lighting to what is essential.
	Notifications	Info-i	<ul style="list-style-type: none"> ▪ On ¹ ▪ Off 	Display or hide additional information Tip: If you press  , the display shows additional information → <i>Page 17</i> . If you switch off the function, the display does not show any symbol or any additional information.
		Pop-up hints	<ul style="list-style-type: none"> ▪ On ¹ ▪ Off 	Displays or hides pop-up notifications → <i>Page 17</i>
		Hidden notifications	Restore	Displays hidden notifications again
	Language	-	<ul style="list-style-type: none"> ▪ German ▪ French ▪ [...] ▪ English ¹ 	Setting the language
	Time and units	Time	<ul style="list-style-type: none"> ▪ Time ¹ ▪ "Automatic": Select the "Automatic" option if your appliance is connected to Home Connect®. 	Set the time
		Time format	<ul style="list-style-type: none"> ▪ 12 ▪ 24 ¹ 	Set the time format
		Temperature unit	<ul style="list-style-type: none"> ▪ °C ¹ ▪ °F 	Set the temperature unit
		Weight unit	<ul style="list-style-type: none"> ▪ "Metric": "g/kg" ▪ "Imperial": "oz/lb" 	Set the weight unit
	Advanced	Demo mode	<ul style="list-style-type: none"> ▪ On ▪ Off ¹ 	Activates or deactivates demo mode Note: The setting is only available in the first 3 minutes after connecting to the power supply.
		Factory settings	<ul style="list-style-type: none"> ▪ Restore 	Resets the appliance to the factory settings Note: The appliance starts the initialization. The display asks you to specify settings that the appliance installer has implemented.

¹ Factory setting (may vary according to model)

Symbol	Basic setting	Setting	Selection	Use
	Appliance	Start screen	<ul style="list-style-type: none"> ▪ Microwave¹ ▪ Manual ▪ Favorites ▪ Programs 	Select a display that shows the display after switching on "Manual" corresponds to oven mode.
		Food preference	<ul style="list-style-type: none"> ▪ Off¹ ▪ Vegetarian ▪ No meat & poultry ▪ No fish & seafood ▪ No pork ▪ Kosher 	Selects the preferred food for automatic programs and recommended settings
		Microwave automatic resume	<ul style="list-style-type: none"> ▪ On ▪ Off¹ 	If the door is opened while the microwave is operating, the appliance restarts automatically as soon as the door is closed again.
		Count-up cooking timer	<ul style="list-style-type: none"> ▪ On¹ ▪ Off 	<p>Sets the total cooking time timer</p> <p>Note: The running cooking time is automatically counted up if no cooking time has been stored.</p>
		User detection	<p>"Behavior":</p> <ul style="list-style-type: none"> ▪ Automatic ▪ "Below 3' 11" (1.2 m)"- "Below 4" (0.1 m)" <p>"Installation height":</p> <ul style="list-style-type: none"> ▪ Under 91.4 cm/36" ▪ Between 91.4 cm/36" and 150 cm/59"¹ ▪ Over 150 cm/59" 	<ul style="list-style-type: none"> ▪ Sets the distance from which the proximity sensor detects the user ▪ Set the appliance's installation height <p>Note: To ensure that the proximity sensor optimally detects the user, store the installation height of the appliance's upper edge.</p>
		Introduction to the appliance	Start	<p>Start the appliance introduction</p> <p>Note: The appliance introduction contains a short description of the basic functions.</p>

19.2 Changing the basic settings

1. Swipe repeatedly from left to right until the display shows Basic settings → *Page 37*.
- ✓ The display shows the symbols for the available settings in a ring menu.
2. Use the control ring to select the required basic setting.
3. Press the required basic setting.
- ✓ The display shows the settings for the selected basic setting.

4. Depending on the selected basic setting, use the control ring to select the setting, or press the required setting.
 - ▶ With a list menu, ensure that the required setting is above the horizontal line.
5. Use  to activate the setting or use the control ring to select the setting option, and press the setting.
6. If required, use < to switch to the previous view.

¹ Factory setting (may vary according to model)

20 Cleaning and maintenance

Note: The Statement of Limited Product Warranty covers defects in materials and workmanship. Cleaning and maintenance is not covered by the warranty and a charge will apply. See the Statement of Limited Product Warranty for more details.

20.1 Cleaning agents

To avoid damaging the various surfaces on the appliance, do not use any unsuitable cleaning agents.

WARNING

Moisture intrusion may cause an electric shock.

- ▶ Do not use any steam cleaners or high-pressure cleaners to clean the appliance.

WARNING

The appliance and its parts that can be touched become hot during use.

- ▶ Caution should be exercised here in order to avoid touching heating elements.
- ▶ Young children under 8 years of age must be kept away from the appliance.

WARNING

Scratched glass in the appliance door may develop into a crack.

- ▶ Do not use any harsh or abrasive cleaners or sharp metal scrapers to clean the glass on the appliance door, as they may scratch the surface.

Suitable cleaning agents

Only use cleaning agents that are suitable for the different surfaces on your appliance.

Appliance door

Area	Suitable cleaning agents	Information
Door pane	<ul style="list-style-type: none"> ▪ Glass cleaner 	Do not use a glass scraper. Clean it using a soft cloth or a microfiber cloth.
Control ring	<ul style="list-style-type: none"> ▪ Soapy water 	Clean with a slightly damp soft cloth. Do not spray with any cleaning agent.

Cooking compartment

Area	Suitable cleaning agents	Information
Oven cavity inner walls	<ul style="list-style-type: none"> ▪ Hot soapy water 	<p>Clean with a dishcloth and dry with a soft cloth. Stainless steel cleaner that is suitable for the appliance can be obtained from customer service or online.</p> <p>To prevent corrosion, remove any patches of limescale, grease, starch or albumin (e.g. egg white) from stainless steel surfaces immediately. Corrosion may form under such stains.</p> <p>Do not use oven spray or other aggressive oven cleaners or abrasive materials. Scouring pads, rough sponges and pan cleaners are unsuitable. These items scratch the surface.</p> <p>Always dry the cooking compartment after cleaning.</p> <p>Note: Undissolved detergent causes patches to appear when heating up and these patches cannot be removed. Thoroughly remove residues from detergents or care products using clean water before drying the oven cavity.</p>

NOTICE

Unsuitable cleaning agents damage the surfaces of the appliance.

- ▶ Do not use harsh or abrasive cleaning agents.
- ▶ Do not use cleaning agents with a high alcohol content.
- ▶ Do not use hard scouring pads or cleaning sponges.
- ▶ Do not use any special cleaners for cleaning the appliance while it is hot.
- ▶ Only use glass cleaners, glass scrapers or stainless steel care products if recommended in the cleaning instructions for the relevant part.

Salt contained in new sponge cloths may damage surfaces.

- ▶ Wash new sponge cloths thoroughly before use. Using oven cleaner in a hot oven cavity damages the stainless steel surfaces.
- ▶ Never use oven cleaner in the oven cavity when it is still warm.
- ▶ Remove all food remnants from the oven cavity and the appliance door before you next heat up the appliance.

WARNING

Loose food remnants, fat and meat juices may catch fire.

- ▶ Before using the appliance, remove the worst of the food residues and remnants from the oven cavity, heating elements and accessories.

Area	Suitable cleaning agents	Information
		Tip: To eliminate unpleasant odors, heat up a cup of water with a few drops of lemon juice for 1 to 2 minutes at the maximum microwave output setting. Always place a spoon in the container to prevent delayed boiling.
Very dirty oven cavity	▪ Cleaning aid	The cleaning aid → <i>Page 44</i> program removes stubborn dirt.
Broiler	▪ Hot soapy water	Clean with a dish cloth or sponge, and dry with a soft cloth.
Glass cover for the oven cavity light	▪ Hot soapy water	Clean with a dish cloth.
Glass floor	▪ Hot soapy water ▪ Glass cleaner	Do not use a glass scraper. Clean with a soft dish cloth and dry with a soft cloth.
Shelf support	▪ Hot soapy water	Note: If required, remove the shelf supports for cleaning. → <i>"Removing the shelf supports", Page 44</i> In the event of heavy soiling, leave to soak and use a brush. Do not clean in the dishwasher.
Wire rack	▪ Hot soapy water	In the event of heavy soiling, leave to soak and use a brush. Do not clean in the dishwasher.
Glass tray	▪ Dishwasher ▪ Hot soapy water	Soak burned-on residues and remove with a brush.
Core temperature probe	▪ Hot soapy water	Wipe with a damp cloth Do not clean in the dishwasher.

20.2 Microfiber cloth

The honeycomb microfiber cloth is especially suitable for cleaning easily damaged surfaces, such as glass, glass ceramic, stainless steel or aluminum. The microfiber cloth removes liquid and greasy deposits in one go.

The microfiber cloth can be obtained from customer service or from the online shop.

20.3 Removing the shelf supports

1. Place a dishcloth in the oven cavity to protect the stainless steel from scratches.
2. Undo the knurled nuts.

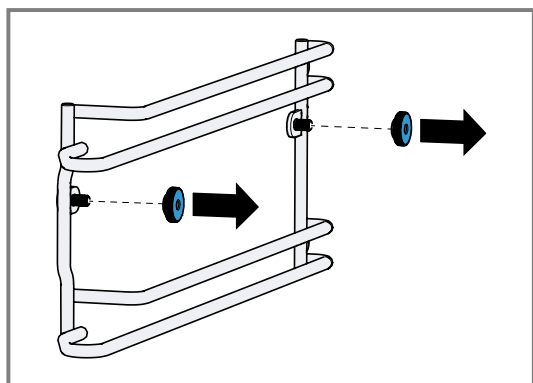

3. Lift the shelf supports slightly sideways away from the screws ① and pull them out towards the front ②.

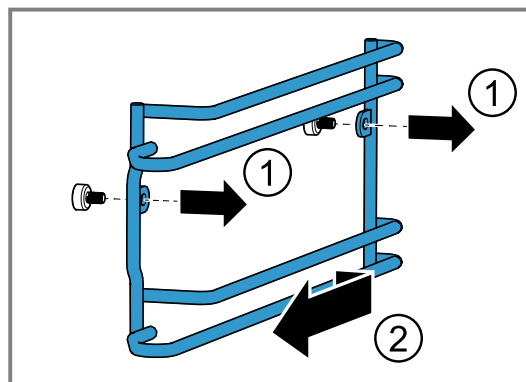

4. Clean the shelf supports with hot soapy water.

20.4 Cleaning aid

The cleaning aid loosens stubborn dirt in the cooking compartment and makes cleaning easier. Always allow the cleaning aid to run to the end. You cannot cancel the cleaning aid.

Preparing the cleaning aid

Requirement: The interior oven temperature is below 40 °C.

1. Remove all accessories from the oven cavity.
2. Remove the shelf supports from the cooking compartment. → *Page 44*
3. Clean the accessories and side shelf supports separately.
4. Wipe out any coarse dirt.
5. Apply a cleaning agent to dirty surfaces in the cooking compartment.

6. Place a microwave-safe dish with a drop of dishwashing liquid and 200 ml of water in the middle of the cooking compartment.
7. Place a spoon in the dish to prevent delayed boiling.
8. Close the appliance door.

Starting the cleaning aid

Note: The appliance will take you through the necessary steps.

1. Swipe repeatedly from left to right until the display shows "Modes & Service".
- ✓ The display shows the available functions in a list menu.
2. Use the control ring to select the "Cleaning aid" function.
3. Press the "Cleaning aid" list item.
4. Switch to the next window with →.
5. Press ▶ to start.
- ✓ The cleaning time counts down.
- ✓ The light in the oven cavity remains switched off.
- ✓ An audible signal will sound once the cleaning time has elapsed.
- ✓ The display shows a message.
6. Wipe out the oven cavity.
7. Wipe the oven cavity dry with a soft cloth.
8. Before using the oven again, remove any detergent residue from the oven cavity.
9. Leave the cooking compartment to dry with the door open.
10. Fit the shelf supports. → *Page 45*
→ *"Fitting the shelf supports", Page 45*

Note: If the cleaning aid was canceled due to a power cut, it must be restarted before using the oven again in order to remove any detergent residues from the appliance.

20.5 Fitting the shelf supports

⚠ WARNING

Loose knurled screws can become very hot during operation.

- ▶ Ensure that the knurled screws for installing the shelf supports are screwed in tightly.

NOTICE

Loose knurled screws may cause sparks to form during microwave operation.

They damage the appliance by producing sparks.

- ▶ Ensure that the knurled screws for installing the shelf supports are screwed in tightly.

Incorrect spare parts may lead to corrosion in the oven cavity.

- ▶ Only use the original knurled nuts.

1. Fit the shelf supports on the correct side of the cooking compartment.

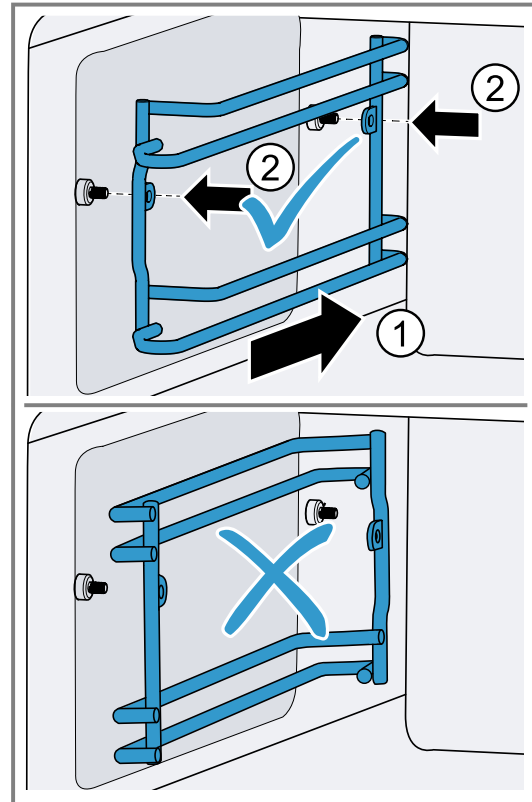

The shelf supports for the left and right side of the cooking compartment are different.

2. Tighten the knurled nuts.

Note: If you lose a knurled nut, you can order this as a spare part from our customer service.

20.6 Cleaning the accessories

1. Read the information on cleaning products.
→ *Page 43*
2. Soften baked-on food remnants with a damp dish cloth and hot soapy water.
3. Clean the accessory with hot soapy water and a soft dish cloth or a scrubbing brush.
4. Clean the wire rack.
Use oven cleaner to remove very heavy soiling.
5. Dry with a soft cloth.

20.7 Cleaning the glass floor

1. Read the information on cleaning products.
→ *Page 43*
2. Clean the glass floor with hot detergent solution or a glass cleaner and a soft dish cloth.
Do not use a glass scraper.
3. Dry with a soft cloth.

21 How it works

Here, you can find the ideal settings for various dishes as well as the best accessories and cookware. We have perfectly tailored these recommendations to your appliance.

21.1 What is the best way to proceed?

Tip

Cooking tips

- The recommended settings always apply to the cooking compartment when it is cold and empty.
- The times specified in the overviews are intended as a guide only. They depend on the quality and composition of the food.

WARNING

Foods with peel or skin may burst or explode during heating, or even afterwards.

- ▶ Never cook eggs in their shells or heat hard-boiled eggs in their shells.
- ▶ Never cook shellfish or crustaceans.
- ▶ Always prick the yolk of eggs before microwaving.
- ▶ The skin of foods that have a peel or skin, such as apples, tomatoes, potatoes and sausages, may burst. Before heating, prick the peel or skin.

NOTICE

Acidic food may damage the wire rack.

- ▶ Do not place acidic food, such as fruit or food with an acidic marinade directly on the wire rack.

Note: Information for those allergic to nickel

In rare cases, small amounts of nickel may pass into the food.

1. Before using the appliance, remove all unnecessary cookware from the cooking compartment.
2. Select the required food from the recommended settings.
3. Place the food in suitable cookware.
4. Place the cookware in the middle on the cooking compartment floor.
The food will then absorb the microwaves from all sides.

5. Use the recommended settings when configuring the appliance settings.
Set the shorter cooking time first. If necessary, increase the cooking time.
6. Use a pot-holder when taking hot cookware out of the cooking compartment.

21.2 General cooking tips

Take note of the following information when cooking all types of food.

- The cooking times specified are intended as a guide. The actual cooking time depends on the quality and temperature of the food before cooking, as well as its weight and thickness.
- Use the cookware specified. If you use other cookware, cooking times may be longer or shorter.
- Always use plates, baking tins or ovenproof dishes with the wire rack.
- If you have not made a particular dish before, start with the shortest specified time. If required, you can continue to cook the food.
- Open the oven cavity door on the preheated oven for a short time only and quickly place your food inside the appliance.
- When defrosting, dough proving and reheating, you can use up to 2 rack levels at a time (rack levels 1 and 2). The specified cooking times may need to be extended for large quantities of food.
- If you are baking on just one level, use level 1.
- Ensure that the food does not lie against the oven cavity or the back panel.
- When cooking at temperatures up to 210 °F (100 °C), no preheating is necessary. Place the food in the cold oven cavity and then switch on the appliance. Preheating is only necessary for the "Hot air" type of heating and temperatures above 210 °F (100 °C).

22 Troubleshooting

You can eliminate minor issues on your appliance yourself. Please read the information on eliminating issues before contacting Customer Service. This may avoid unnecessary repair visits.



WARNING

To avoid risk of injury from improper repairs, observe the following.

- ▶ Only qualified technicians or authorized service providers should perform repairs.
- ▶ If the power cord of this appliance becomes damaged, it must be replaced by the manufacturer, the manufacturer's Customer Service, or an authorized service provider in order to prevent injury.
- ▶ Only genuine spare parts may be used to repair the appliance.
- ▶ If the appliance has an issue, call Customer Service.

22.1 Malfunctions

Fault	Cause and troubleshooting
The appliance is not working.	The plug for the power cord is not plugged in.
	▶ Connect the appliance to the power supply.
	The circuit breaker in the circuit breaker panel has tripped.
	▶ Check the breaker panel.
	There has been a power failure.
	▶ Check whether the lighting in your kitchen or other appliances in the room are working.

Fault	Cause and troubleshooting
The appliance is not working.	Operational fault <ol style="list-style-type: none"> 1. Switch off the fuse in the fuse box. 2. Switch the fuse on after approx. 10 seconds. 3. If the malfunction occurs again, call customer service.
The appliance does not start.	The appliance door is not fully closed. ▶ Close the appliance door.
The appliance cannot be started via the Home Connect® app.	The appliance is not connected to the Home Connect® app. ▶ Start the connection between the appliance and the Home Connect® app. → <i>"Setting up Home Connect®", Page 36</i> The appliance is connected to the Home Connect® app but the remote control function is not activated. ▶ Activate the remote control function in the Home Connect settings → <i>Page 36</i> .
Food takes longer than usual to heat up.	The microwave output is set too low. ▶ Set a higher microwave output. → <i>Page 23</i> A larger amount than usual has been placed in the appliance. ▶ Set a longer cooking time. You need double the time when you have double the amount. The food is colder than usual. ▶ Turn or stir the food from time to time during cooking.
The appliance is not working. The display does not respond. The display shows the symbol for the childproof lock  .	Childproof lock is activated. ▶ Deactivate the childproof lock. → <i>Page 30</i>
The appliance automatically switches off.	Safety switch-off function: No operation for more than 12 hours. <ol style="list-style-type: none"> 1. Press ✓ to confirm the message. 2. Switch off the appliance.
The appliance does not heat up; the display shows the symbol for the demo mode  .	The appliance is in demo mode. ▶ Deactivate the demo mode in the basic settings → <i>Page 37</i> .
The lighting does not work.	The lighting is defective. <ol style="list-style-type: none"> 1. Switch off the fuse in the fuse box. 2. Switch the fuse on after approx. 10 seconds. 3. If the malfunction occurs again, call customer service.

22.2 Display information

Fault	Cause and troubleshooting
The display shows the error message "Exx".	An error occurred. <ol style="list-style-type: none"> 1. If the display shows an error message, press . ✓ If the display no longer shows the error message, it was a one-off problem. 2. If the display continues to show or repeatedly shows the error message, contact customer service → <i>Page 48</i> and provide them with the error code.
Display shows "Initialization".	The initial start-up was not completed successfully. ▶ Carry out initial start-up. → <i>"Initial use", Page 20</i> The appliance's factory settings were restored. ▶ Carry out initial start-up. → <i>"Initial use", Page 20</i> Demo mode was activated during initial start-up and has now been deactivated. ▶ Carry out initial start-up. → <i>"Initial use", Page 20</i>

22.3 Demo mode

If the display shows , demo mode is activated. The appliance does not heat up.

Deactivating demo mode

1. To briefly disconnect the appliance from the mains, switch off the household fuse or the circuit breaker in the fuse box.
2. Deactivate demo mode within 3 minutes in the basic settings → *Page 37*.

23 Disposal

23.1 Disposal of your old appliance

Environmentally compatible disposal allows valuable raw materials to be recycled.

- ▶ Dispose of the appliance in an environmentally responsible manner. Information about current disposal methods can be obtained from your specialist dealer or local authority.

24 Customer Service

With any warranty repair, we will make sure your appliance is repaired by an authorized service provider using genuine replacement parts. We use only genuine replacement parts for all repairs.

You can obtain function-relevant and storable genuine spare parts from our Customer Service for up to 15 years from the date on which your appliance was placed on the market.

For more information, please contact our Customer Service team.

Detailed information on the warranty period and terms of warranty can be found in the Statement of Limited Product Warranty, from your retailer, or on our website. The LED light sources are available as a spare part and should only be replaced by an authorized service provider.

USA:

1-877-442-4436

www.gaggenau.com

www.gaggenau.com/us/appliances/eshop

CA:

1-877-442-4436

www.gaggenau.com

www.gaggenau.ca

For assistance with connecting to Home Connect®, you can also view instructions here:

www.home-connect.com/us/en/help-support/set-up

24.1 Model number (E-Nr.), production number (FD) and consecutive numbering (Z-Nr.)

If you contact Customer Service, you will need the product number (E-Nr.), production number (FD), and con-

secutive numbering (Z-Nr.), which you can find on the appliance's rating label.

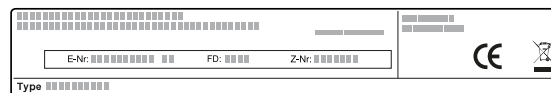

Making a note of your appliance's details and the Customer Service telephone number will enable you to find them again quickly.

24.2 Rating plate location

The rating plate is located at the door frame close to the lower door hinge.

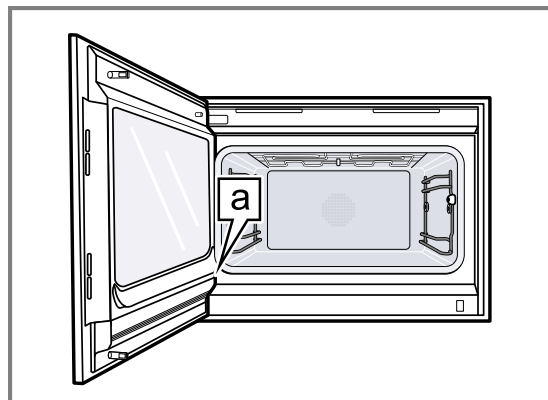

a Rating plate

25 Information regarding Free and Open Source Software

This product includes software components that are licensed by the copyright holders as free or open source software.

The applicable license information is stored on your home appliance. You can also access the applicable license information via your Home Connect® app: "Profile -> Legal information -> License Information".¹ You can also download the license information on the brand product website. (Please search on the product website for your appliance model and additional documents). Alternatively, you can request the relevant information

from ossrequest@bshg.com or BSH Hausgeräte GmbH, Carl-Wery-Str. 34, 81739 Munich, Germany.

The relevant source code will be made available to you on request.

Please send your request to ossrequest@bshg.com or BSH Hausgeräte GmbH, Carl-Wery-Str.34, 81739 Munich, Germany.

Subject: „OSSREQUEST“

The cost of performing your request will be charged to you. This offer is valid for three years from the date of purchase or at least as long as we offer support and spare parts for the relevant appliance.

¹ Depending on the appliance specifications

26 STATEMENT OF LIMITED PRODUCT WARRANTY

26.1 What this warranty covers & Who it applies to

The limited warranty provided by BSH Home Appliances (“Gaggenau”) in this Statement of Limited Product Warranty applies only to the Gaggenau appliance sold to you (“Product”), provided that the Product was purchased on or after January 1, 2025:

- For your normal, household (non-commercial) use, and has in fact at all times only been used for normal household purposes.
- New at retail from a BSH authorized dealer or directly from BSH (not a display, "as is", or previously returned model), and not for resale, or commercial use.
- Within the United States or Canada, and has at all times remained within the country of original purchase.

The warranties stated herein apply to the original purchaser of the product warranted herein and to each succeeding owner of the product purchased for ordinary home use during the term of the warranty.

Please make sure to register your Product; while not necessary to effectuate warranty coverage, it is the best way for Gaggenau to notify you in the unlikely event of a safety notice or product recall.

26.2 How long the warranty lasts

Gaggenau warrants that the Product is free from defects in materials and workmanship for a period of five (5) years from the date of the original delivery. The warranty shall only be extended for the time that elapsed between the date of your warranty claim and the date of the completed repair or replacement. This Product is also warranted to be free from **cosmetic** defects in material and workmanship (such as scratches of stainless steel, paint/porcelain blemishes, chips, dents, or other damage to the finish) of the Product, for a period of sixty (60) days from the date of delivery or closing date for new construction. This **cosmetic** warranty excludes slight color variations due to inherent differences in painted and porcelain parts, as well as differences caused by kitchen lighting, product location, or other similar factors. This **cosmetic** warranty specifically excludes any display, floor, “As Is”, or “B” stock appliances.

26.3 Repair/replace as your exclusive remedy

During this warranty period, Gaggenau or one of its authorized service providers will repair your Product without charge to you (subject to certain limitations stated herein) if your Product proves to have been manufactured with a defect in materials or workmanship. If reasonable attempts to repair the Product have been made without success, then Gaggenau will replace your Product (upgraded models may be available to you, in Gaggenau's sole discretion, for an additional charge). Nothing in this warranty requires damaged or defective parts to be replaced with parts of a different type or design than the original parts. All removed parts and com-

ponents shall become the property of Gaggenau at its sole option. All replaced and/or repaired parts shall assume the identity of the original part for purposes of this warranty and this warranty shall not be extended with respect to such parts. Gaggenau's sole liability and responsibility hereunder is to repair manufacturer-defective Product only, using a Gaggenau authorized service provider during normal business hours. For safety and property damage concerns, Gaggenau highly recommends that you do not attempt to repair the Product yourself, or use a non-authorized service provider; Gaggenau will have no responsibility or liability for damage resulting from repairs or work performed by a non-authorized service provider. Authorized service providers are those persons or companies that have been specially trained on Gaggenau products, and who possess, in Gaggenau's opinion, a superior reputation for customer service and technical ability (note that they are independent entities and are not agents, partners, affiliates or representatives of Gaggenau). Nevertheless, taking your product to be serviced by a repair shop that is not affiliated with or an authorized dealer of Gaggenau will not void this warranty. Also, using third-party parts will not void this warranty. Notwithstanding the foregoing, Gaggenau will not incur any liability, or have responsibility, for the Product if it is located in a remote area (more than 100 miles from an authorized service provider) or is reasonably inaccessible, hazardous, threatening, or treacherous locale, surroundings, or environment; in any such event, if you request, Gaggenau would still pay for labor and parts and ship the parts to the nearest authorized service provider, but you would still be fully liable and responsible for any travel time or other special charges by the service company, assuming they agree to make the service call. Further, to the extent you have installed the Product in a difficult-to-access location or have otherwise installed temporary or permanent fixtures that create barriers to accessing or removing the Product, Gaggenau will not incur any liability for, or have responsibility, for work or costs associated with moving the Product or otherwise creating access to the Product in order to repair or replace it. All such costs shall be your sole responsibility.

26.4 Out of warranty product

Gaggenau is under no obligation, at law or otherwise, to provide you with any concessions, including repairs, prorates, or Product replacement, once this warranty has expired.

26.5 Warranty exclusions

The warranty coverage described herein excludes all defects or damage that are not the direct fault of Gaggenau, including without limitation, one or more of the following:

- Use of the Product in anything other than its normal, customary and intended manner (including without limitation, any form of commercial use, use or storage of an indoor product outdoors, use of the Product in conjunction with air or water-going vessels).

- Any party's willful misconduct, negligence, misuse, abuse, accidents, neglect, improper operation, failure to maintain, improper or negligent installation, tampering, failure to follow operating instructions, mishandling, unauthorized service (including selfperformed "fixing" or exploration of the appliance's internal workings).
- Adjustment, alteration or modification of any kind.
- A failure to comply with any applicable state, local, city, or county electrical, plumbing and/or building codes, regulations, or laws, including failure to install the product in strict conformity with local fire and building codes and regulations.
- Ordinary wear and tear, spills of food, liquid, grease accumulations, or other substances that accumulate on, in, or around the Product.
- Any external, elemental and/or environmental forces and factors, including without limitation, rain, wind, sand, floods, fires, mud slides, freezing temperatures, excessive moisture or extended exposure to humidity, lightning, power surges, structural failures surrounding the appliance, and acts of God.
- Service calls to correct the installation of your Product, to instruct you how to use your Product, to replace house fuses or correct house wiring or plumbing.
- Removal and replacement of trim or decorative panels that interfere with servicing the Product.
- Damage or defects caused by labor or parts installed by any non-authorized service provider, unless approved by Gaggenau before service is performed.

In no event shall Gaggenau have any liability or responsibility whatsoever for damage to surrounding property, including cabinetry, floors, ceilings, and other structures or objects around the Product. Also excluded from this warranty are Products, on which the serial numbers have been altered, defaced, or removed; service visits to teach you how to use the Product, or visits where there is nothing wrong with the Product; correction of installation problems (you are solely responsible for any structure and setting for the Product, including all electrical, plumbing or other connecting facilities, for proper foundation/flooring, and for any alterations including without limitation cabinetry, walls, floors, shelving, etc.); and resetting of breakers or fuses.

TO THE EXTENT ALLOWED BY LAW, THIS WARRANTY SETS OUT YOUR EXCLUSIVE REMEDIES WITH RESPECT TO PRODUCT, WHETHER THE CLAIM ARISES IN CONTRACT OR TORT (INCLUDING STRICT LIABILITY, OR NEGLIGENCE) OR OTHERWISE. THIS WARRANTY IS IN LIEU OF ALL OTHER WARRANTIES, WHETHER EXPRESS OR IMPLIED. ANY WARRANTY IMPLIED BY LAW, WHETHER FOR MERCHANTABILITY OR FITNESS FOR A PARTICULAR PURPOSE, OR OTHERWISE, SHALL BE EFFECTIVE ONLY FOR THE PERIOD THAT THIS EXPRESS LIMITED WARRANTY IS EFFECTIVE. IN NO EVENT WILL THE MANUFACTURER BE LIABLE FOR CONSEQUENTIAL, SPECIAL, INCIDENTAL, INDIRECT, "BUSINESS LOSS", AND/OR PUNITIVE DAMAGES, LOSSES, OR EXPENSES, INCLUDING WITHOUT LIMITATION TIME AWAY FROM WORK, HOTELS AND/OR RESTAURANT MEALS, REMODELLING EXPENSES IN EXCESS OF DIRECT DAMAGES WHICH ARE DEFINITELY CAUSED EXCLUSIVELY BY GAGGENAU, OR OTHERWISE. SOME STATES DO NOT ALLOW THE EX-

CLUSION OR LIMITATION OF INCIDENTAL OR CONSEQUENTIAL DAMAGES, AND SOME STATES DO NOT ALLOW LIMITATIONS ON HOW LONG AN IMPLIED WARRANTY LASTS, SO THE ABOVE EXCLUSIONS OR LIMITATIONS MAY NOT APPLY TO YOU. THIS WARRANTY GIVES YOU SPECIFIC LEGAL RIGHTS, AND YOU MAY ALSO HAVE OTHER RIGHTS WHICH VARY FROM STATE TO STATE.

No attempt to alter, modify or amend this warranty shall be effective unless authorized in writing by an officer of BSH.

26.6 Obtaining warranty service

To obtain warranty service for your product, you should contact Gaggenau Customer Support at 1-877-442-4436 to schedule a repair.

26.7 Product information

For handy reference, copy the information below from the rating plate. Keep your invoice and/or delivery documents for warranty validation.

Model number (E-Nr.)

Production number (FD)

Date of delivery

The difference is Gaggenau

gaggenau.com

BSH Home Appliances Corporation

1901 Main Street, Suite 600

Irvine, CA 92614

USA

www.gaggenau.com

1-877-442-4436

© 2026 BSH Home Appliances Corporation



9001954868 (060402)

en-us