



Vario 200 series gas wok
VG 231

VG 231 220CA

Black aluminum control panel.

Width 12" (28 cm).

Natural gas.

For conversion to LP gas, LP kit (part#10009475) must be ordered.

Included accessories

1 wok attachment ring.

Installation accessories

VV 200 010

Stainless steel connection strip for combination with other Vario appliances of the 200 series.

VV 200 020

Black connection strip for combination with other Vario appliances of the 200 series.

Optional accessories

VD 200 020

Black appliance cover.

WP 400 001

Wok pan made of multiple-layer material.

With round bottom and handle, $\varnothing 14 \frac{3}{16}$ ", 6.3 qt., height 4".

LS 041 001

Stainless steel, removable air deflector for gas Vario next to VL 200 downdraft.

Combinable with:

2x VL 200 120

AW 442 720

AI 230 700

AW 230 790

AF 210 791

Good to know:

Wall installations require the hood to be as large as the cooktop(s). Island installations require the hood to be larger than the cooktop(s).

Highlights

- Can be combined with other Vario 200 series products.
- Control panel for comfortable and secure operation.
- Mechanical power level regulation for 9 power levels, with exact setting and reproduction of flame size.
- Multi-ring burner of solid, heat-resistant brass as used in professional kitchen.
- Total output up to 18,800 BTU (5.5 kW).

Cooking zones

1 multi-ring wok burner. 1,000 - 18,800 BTU (300 - 5,500 W), suitable for woks and pots up to $\varnothing 12 \frac{5}{8}$ ".

Operation

Control knobs with illuminated ring. Integrated control panel. One-handed operation. Electric ignition. To close the cover, the cast iron pan support can be easily reversed.

Features

Cast iron pan support. Brass burner rings.

Safety

Thermoelectric safety pilot. Residual heat indication. Operation indicator.

Planning notes

Equipped for natural gas. For conversion to LP gas, LP kit (part#10009475) must be ordered. If using the VL200 downdraft for ventilation, the Vario gas wok must be placed between two VL downdrafts. Recirculation is not recommended. Appliance can be snapped into the countertop from above. A minimum clearance of at least 6" (150 mm) from adjacent heat-sensitive cabinet or contact surfaces must be observed or thermal insulation fitted. With a total connected load of more than 37,533 BTU (11 kW) local regulations concerning room ventilation, room size and combination of extraction or recirculation hoods must be observed. Minimum clearance between gas cooktop(s) with more than 37,533 BTU (11 kW) and ventilation hood 27 $\frac{1}{2}$ " (70 cm). Appliance weight: approx. 24 lbs (11 kg).

Please read additional planning notes on page 117.

Rating

Rating: 10 W (18,800 BTU). Minimum fuse protection: 15 A. Electrical: 120 V / 60 Hz. Electrical connection: Plan for a 59" long connecting cable with 3 prong NEMA 5-15 plug.

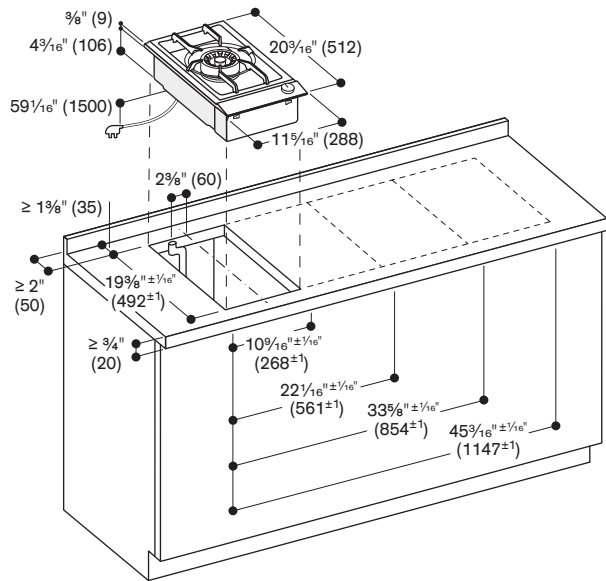

Minimum distance from the appliance cut-out to the side wall 11 $\frac{13}{16}$ " (300 mm).

Gas connection

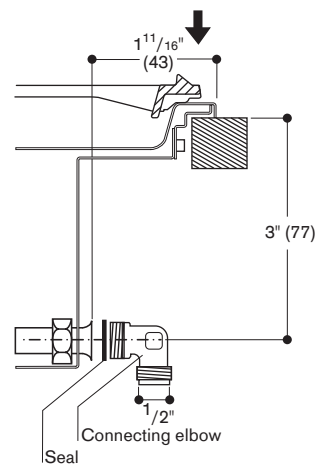

Numbers indicated inside parenthesis () = mm

www.gaggenau.com/us
Revised: March 2025