

DA 2360

Insert ventilation hood

with energy-efficient LED lighting and backlit controls for easy use.



- Customized kitchen design – fully integrated in 23 (584) in (mm) width
- Space saving – suitable for narrow wall units from 11.8" deep
- Powerful – ?? on the booster setting
- Efficient filtration- 10-ply stainless steel grease filters
- Safe and easy to clean – Miele CleanCover

EAN: 4002515949887 / Material number: 10765130 / Old Material Number: 28236055USA

<b>Construction type</b>	
Insert ventilation extractor	•
<b>Operating modes</b>	
Recirculated mode	Convertible
Recirculation conversion kit (order separately)	DUU 151
OdorFree charcoal filter (order separately)	DKF19-900
<b>Design</b>	
Color	Stainless steel
<b>Control panel</b>	
Electronic controls	•
Power levels (number excl. Intensive)	3
<b>Cleaning convenience</b>	
Easy-to-clean canopy interior – CleanCover	•
<b>Filter system</b>	
Number of dishwasher safe stainless-steel grease filters (10-ply)	1
<b>Lighting</b>	
LED ClearView lighting	•
Number x W	2 x 3 W
Light intensity in Lx	350 lx
Color temperature in K	3000 Kelvin
<b>Blower</b>	
Dual-action blower	•
AC motor	•
<b>Extraction</b>	
Air throughput	Values upon request
<b>Safety</b>	
Safety shut-off	•
<b>Technical data</b>	
Canopy width in in.(mm)	23 (584)
Canopy height in in.(mm)	2 1/2 (63)
Canopy depth in in.(mm)	11 3/4 (297)
Minimum height above electric hobs in mm	24 1/8 (610)
Minimum height above gas hobs (max. 12.6 kW total power, burner ≤ 4.5 kW) in mm	26 (660)
Net weight in lbs. (kg)	25 (11.0)
Length of electrical wire in ft (m)	4 (1.5)
Standard plug fitted	•
Total connected load in kW	0.35
Fuse rating in A	15
Voltage in V	120
Frequency in Hz	60
Number of phases	1
<b>Installation notes</b>	
Vent connection at top	•
Vent connection at top and rear	•
Diameter of vent connection in in. (mm)	6 (150)
<b>Optional accessories</b>	
OdorFree charcoal filter	No

DA 2360

Insert ventilation hood

with energy-efficient LED lighting and backlit controls for easy use.

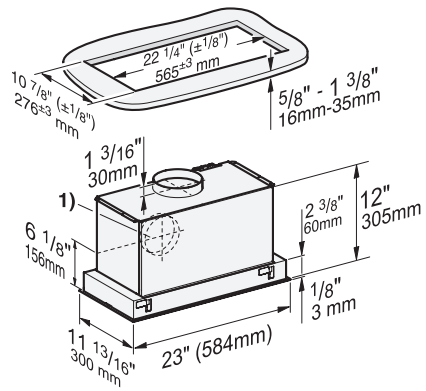

DA 2360 (Installation drawing) – USA

1) Vent connection alternatively to rear