



**200 series island hood**  
**AI 230**

**AI 230 700**

Stainless steel, Width 40" (100 cm).  
HVI CFM: 370, High Speed.  
Air extraction / Air recirculation.  
Standard duct cover included.

**Installation accessories**

**AD 200 326**

Stainless steel duct cover extension,  
Length: 3' 7<sup>5</sup>/<sub>16</sub>" (1,100 mm).

**AD 223 346**

Mounting kit extension.  
Length: 1' 7<sup>1</sup>/<sub>16</sub>" (500 mm). Must be  
ordered in conjunction with the  
AD200326.

**AD 220 396**

Stainless steel ceiling collar, covers  
screws on duct cover and uneven  
gaps of ceilings that are not  
completely flat.

**Optional accessories**

**AA 200 816**

Air recirculation module with  
activated charcoal filter installed on  
the inside of the duct cover.

**Part #11049036**

Activated charcoal filter for  
recirculation module AA442810.

**AD 223 356**

Adapter for roof inclination left/right.

**AD 223 366**

Adapter for roof inclination front/back.

**Good to know:**

The hood has to be larger than the  
cooktop(s) or it has to be as large as  
the cooktop(s). Please check the  
requirements in chapter ventilation.

**HVI Performance Values**  
**(CFM & SONES)**

**Blower Internal**

Exhaust Discharge: vertical  
Speed: High Speed  
Static Pressure (in H<sub>2</sub>O): 0.1"  
HVI Wats: 291  
CFM/Watt: 1.28  
HVI CFM: 370  
Sones (Reportable): 5.5

**Blower Internal**

Exhaust Discharge: vertical  
Speed: Working Speed  
Static Pressure (in H<sub>2</sub>O): 0.023"  
HVI Wats: 196  
CFM/Watt: 0.98  
HVI CFM: 190  
Sones (Reportable): 1.5

**Highlights**

- Highly efficient extraction of cooking vapors.
- Low-noise blower.
- Patented filter technology with high level of grease absorption.
- Rim extraction filter with flat and easy-to-clean stainless steel surface.
- Dimmable LED light for optimum illumination of the entire cooktop.
- Air extraction or recirculation system.
- Air recirculation module with activated charcoal filters: quiet and highly efficient recirculation solution with odor reduction as in air extraction mode, and long replacement intervals.

**Features**

Three electronically controlled power levels and an intensive mode.  
Grease filter saturation indicator.  
Patented rim extraction filter, dishwasher-safe.  
Warm white LED light (3,600 K), continuously dimmable.  
Airflow-optimized interior for efficient air circulation.  
Easy mounting system for simple installation and alignment.  
A one-way flap comes included with the hood.

**Planning notes**

The hood includes a two-part duct cover with dimensions from 2' 1<sup>3</sup>/<sub>16</sub>" (654 mm) to 2' 8<sup>13</sup>/<sub>16</sub>" (834 mm). Individual planning solutions can be accommodated using the optional duct cover accessory AD200326 or by shortening the lower edge of the telescopic duct cover.  
Minimum clearance above gas or induction cooktops is 30".  
The air recirculation module with activated charcoal filter can be installed on the inside of the duct cover.

**Rating**

Total rating: 430 W.  
Total Amps: 3 A.  
120 V / 60 Hz.  
Connecting cable 51<sup>3</sup>/<sub>16</sub>" with plug.

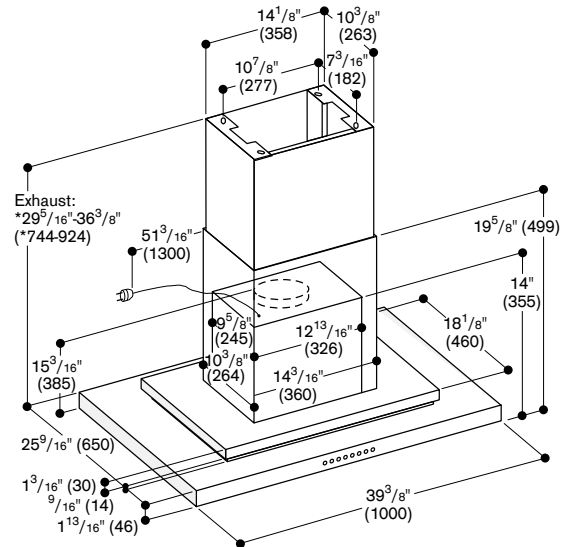

\* Suitable for ceiling heights of 7.7 ft. (2.34 m) to 8.3 ft. (2.52 m);  
Specifications refer to a distance from floor to lower duct cover edge of 5.2 ft. (1.60 m).

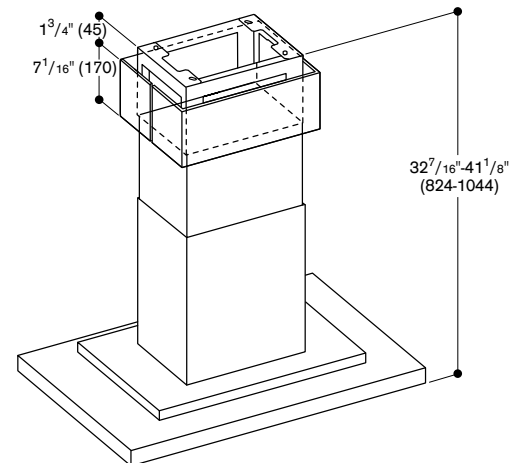

\* Suitable for ceiling heights of 8 ft. (2.42 m) to 8.7 ft. (2.64 m);  
Specifications refer to a distance from floor to lower duct cover edge of 5.2 ft. (1.60 m).

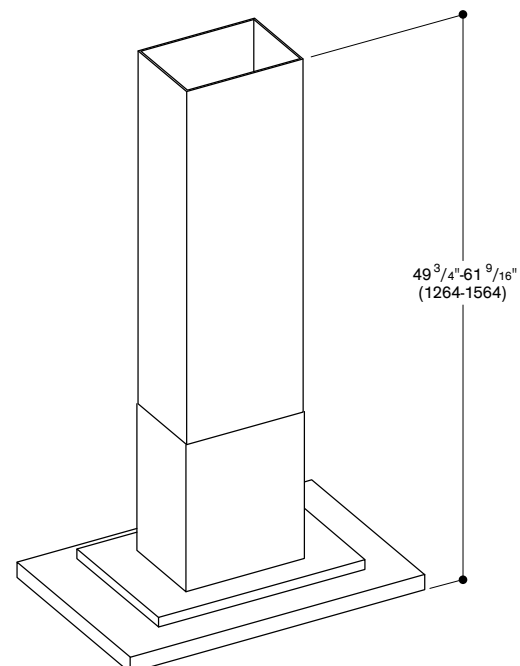

\* Suitable for ceiling heights of 9.4 ft. (2.86 m) to 10.4 ft. (3.16 m);  
Specifications refer to a distance from floor and lower duct cover edge of 5.2 ft. (1.60 m).

Numbers indicated  
inside parenthesis ( ) = mm

www.gaggenau.com/us  
Revised: March 2025