

48" Series 11 Professional 4 Burner + 4 Zone Hybrid Self-Cleaning Range, LPG

Professional



With both induction and gas cooktops and two convection ovens, you're ready to create a feast - guided by an intuitive touchscreen.

- Guided cooking using your touchscreen makes it simple to cook by food, function or recipe.
- Top burner heat of 19,000 BTU, for seriously fast boiling
- Four induction cooking zones, which can be paired to form two SmartZones
- 6.9 cu ft total oven capacity across two oven cavities

DIMENSIONS

Height	35 3/4 - 36 3/4 "
Width	47 7/8 "
Depth	29 1/8 "

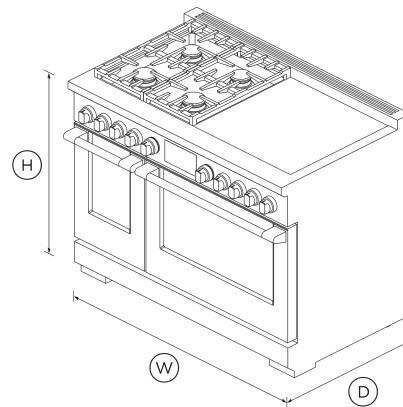

FEATURES & BENEFITS

Cook With Confidence

Our touchscreen interface provides an intuitive guided cooking experience that helps deliver perfect results, whether you've been cooking all your life or just starting out. Cook with a favorite method, a hero ingredient, or a go-to cooking function or recipe. The screen tilts for improved ergonomics and optimal visibility while cooking.

Generous Capacity

Two independently operating cavities provide a large total capacity of 4.8 cu. ft. in the main cavity and 2.1 cu. ft. in the secondary. That's enough room for a 32 lb turkey in one oven, and your sides in the other.

Cooking Flexibility

No matter what you're cooking, you've got the right heat to get perfect results. Each of the 15 oven functions in the main cavity and 11 in the secondary have been extensively researched and carefully designed to cater to a broad range of dishes and cooking styles. The handy food probe helps you monitor your progress.

Cooktop Power

On the gas side of the cooktop, Sealed dual flow burners deliver power up to 19,000 BTU, while the induction side delivers up to 3700W. This finely tuned cooktop provides instant and immediate control from the highest heat to the most gentle simmer.

Design Quality

This range has craftsmanship in every detail, with real stainless steel, cast-iron trivets, and beautifully weighted, halo illuminated dials. Each cavity features incandescent lights and full extension telescopic racks. From the robust legs to the powerful cooktop, this Range is built to last.

Easy To Clean

The oven features a self-cleaning function and self-clean proof side racks, which don't need to be removed when using this function. The induction zones only need a quick wipe after use to keep them clean.

SPECIFICATIONS

Accessories (included)

- Adjustable feet covers •
- Branded coin end cap •

Accessories (sold separately)

Dial kit Professional, Brass	ADLP3RH484BA
Dial kit Professional, Dark Copper	ADLP3RH484DC

Burner ratings

Maximum burner power	19000 BTU
Power back left	13000BTU
Power back right	13000BTU
Power front left	19000BTU
Power front right	13000BTU
Total cooktop power	58000 BTU

Capacity

Shelf positions (main oven)	5
Shelf positions (second oven)	5
Total capacity (main oven)	4.8 cu ft
Total capacity second oven	2.1 cu ft
Usable capacity (main oven)	3.8 cu ft

Cleaning

Easy clean porcelain basepan	•
Pyrolytic self-clean	•

Controls

Dial with illuminated halo	•
Dual control oven dials	•
Electric circuit	4

High resolution display	•
Metal illuminated dials	•
Multi-language interface	•
Precise cooking with food probe	•
recipeAndFoodBasedFunctions	•
Sabbath mode	•
Smart appliance	•
Tilting touch screen interface	•

Gas Requirements

Fitting and pipe	½ NPT, min. 5/8" flex line
Supply Pressure (LPG)	11" to 14" W.C

Main oven features

Concealed Element	•
Electronic oven control	•
Full extension telescopic racks	•
Internal light	•
True convection	•

Main oven functions

Air fry	•
Bake	•
Classic bake	•
Clean	•
Convection broil	•
Maxi broil	•
Number of oven functions	15

Pizza bake	•
Rapid proof	•
Roast	•
Self cleaning	•
Slow cook	•
True convection	•
Warm	•

Oven features

Auto re-ignition system	•
Concealed element	•
Electronic oven control	•
Full extension telescopic sliding shelves	•
True convection	•

Oven functions

Air fry	•
Bake	•
Classic bake	•
Clean	•
Convection bake	•
Convection Broil	•
Dehydrate	•
Maxi Broil	•
Number of functions	15
Pastry bake	•
Pizza bake	•
Rapid proof	•
Roast	•

Slow cook	•
True convection	•
Warm	•

SmartZone	2
Vent trim included	•
Zone bridging	•

3/4 Extension racks	2
Electronic oven control	•
Food probe	•
Internal light	•

Oven performance

Bake	4600 W
Broil	3600 W
Broil power	4000 W
Main oven - True convection power	2500 W

Rangetop Performance

Left front zone rating	2100 (3700) W
Left rear zone rating	2100 (3700) W
Number of cooking zones	4
PowerBoost	•
PowerBoost all zones	up to 3700 W
Right front zone rating	2100 (3700) W
Right rear zone rating	2100 (3700) W

Secondary oven functions

Air fry	•
Bake	•
Classic bake	•
Convection bake	•
Convection broil	•
Maxi broil	•
Number of secondary oven functions	11
Pastry bake	•
Pizza bake	•
Rapid proof	•
Roast	•
Warm	•

Power Requirements

Connection	4-prong grounding type [NEMA 14-50P plug]
Service	50 A
Supply frequency	60 Hz
Supply voltage	208 - 240 V

Recommended Back Guards Ventilation

Combustible situation	BGRV3-3048H
Non combustible situation	BGRV2-3048 / BGRV2-1248
Recommended hood	HCB48-12_N (48" Professional Range Hood, Dual Blower)

Product Dimensions

Depth	29 1/8 "
Height	35 3/4 - 36 3/4 "
Width	47 7/8 "

Safety

ADA compliant	•
Pan detection system	•
Safety time out	•
Surface hot indicators	•

SKU 82793

The product dimensions and specifications in this page apply to the specific product and model. Under our policy of continuous improvement, these dimensions and specifications may change at any time. You should therefore check with Fisher & Paykel's Customer Care Centre to ensure this page correctly describes the model currently available. © Fisher & Paykel Appliances Ltd 2020

Rangetop features

Gentle heat	•
Heat settings	9
Induction cooking technology	•
Sealed range top	•

Secondary oven features

Other product downloads available at fisherpaykel.com

- [↓ DWG](#)
- [↓ DWG](#)
- [↓ DWG](#)
- [↓ DXF](#)
- [↓ DXF](#)
- [↓ DXF](#)
- [↓ DXF](#)
- [↓ Archicad](#)
- [↓ DWG](#)
- [↓ Installation Guide \(English\)](#)
- [↓ Installation Guide \(Canadian French\)](#)
- [↓ Planning Guide - 48" Professional Ranges & Backguards \(English\)](#)
- [↓ California Warning Proposition 65 \(English, Spanish, Canadian French, Chinese\)](#)
- [↓ Revit](#)
- [↓ Rhino](#)
- [↓ Right To Repair Declaration \(English, Canadian French\)](#)
- [↓ SketchUp](#)
- [↓ User Guide \(English\)](#)



A PEACE OF MIND SALE
24 Hours 7 Days a Week Customer Support
T 1.888.936.7872 W www.fisherpaykel.com

Where applicable:

All appliances use energy, and energy usage typically generates carbon emissions. **Fisher & Paykel Appliances' In-use Energy Carbon Emissions Estimate** indicates carbon emissions from a product's in-use energy. This is calculated either annually or per cycle, using the product's market-specific energy label energy consumption data multiplied by the carbon emissions factor for energy in your country or region.

Our In-use Energy Carbon Emissions Estimate is designed to assist customers in making informed purchasing decisions when comparing different Fisher & Paykel products. For example, a heat pump dryer typically has a lower In-use Energy Carbon Emissions Estimate than a vented dryer.