

FEATURES & BENEFITS



STAINLESS SOLID



INTEGRATED SOLID



INTEGRATED SOLID (STAINLESS HANDLELESS PANEL)*

PERFORMANCE	<ul style="list-style-type: none"> • Volume of 4.9 cu ft holds up to 90 bottles (12 oz) or 142 cans (12 oz) • Digital Touch Pad Control is conveniently located on upper face of unit • Temperature range: 34°F - 45°F • Single zone convection cooling system rapidly and efficiently takes items to the set temperature
INTERIOR/EXTERIOR	<ul style="list-style-type: none"> • Black interior is illuminated with LED lighting • Equipped with 2 full-extension robust stainless drawers • Standard commercial stainless steel handle is interchangeable with professional handle accessory • The lower drawer is large enough to fit 2 one-gallon containers with additional space for more storage • Designed to be built-in (galvanized exterior cabinet)
INTEGRATION	<ul style="list-style-type: none"> • Integrated model requires 3/4" custom panel of your choice, or can accept U-Line Handleless Stainless Panel Accessory (must be ordered separately) • Fixed grille can accept a custom integrated toe-kick • Four independently adjustable leveling legs provide a precise undercounter fit

Model Details

Model	Voltage/Hz	Door Swing	Finish	Shipping Weight
U-2224DWRS-00A	115 / 60	Drawers	Stainless Solid	166 lb
U-2224DWRINT-00A	115 / 60	Drawers	Integrated Solid	158 lb

Accessories

Model	Description	Finish	Shipping Weight
ULASHP24DWR*	Stainless Handleless Panel Solid (2 panels)	Stainless	14 lb
ULASD24DWR	Slide and Divide 24" Bin Organizer	N/A	2 lb

*Installs on integrated models.

DIMENSIONS

Dimensions shown apply to all finishes, including Integrated (INT) models with 3/4" integrated panel/frame installed.

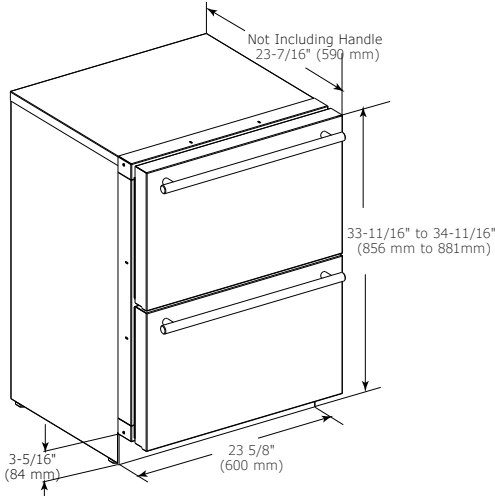

CABINET CUT-OUT

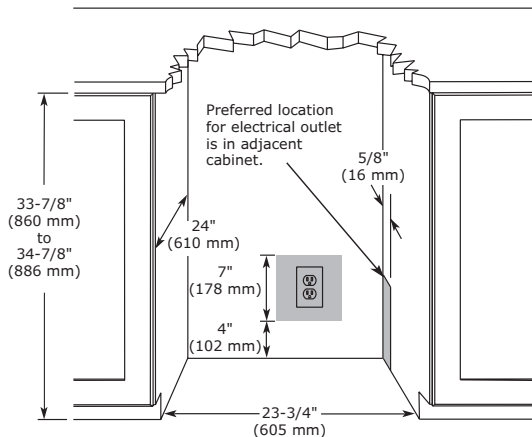

INSTALLATION NOTES

No additional clearance around sides, top or rear of unit is needed for ventilation.

Do not obstruct front grille air flow.

WARRANTY

- 1 Year (parts & labor) / 5 year sealed system (parts)
- + **Additional 1 Year (parts & labor) warranty at no cost with product registration**

See complete warranty for details

SPECIFICATIONS

Model	2224DWR
Amps: Running	1.2
Capacity: Bottle (12 oz)	90
Capacity: Can (12 oz)	142
Capacity: Volume (cu ft)	4.9
Control Type	Digital Touch Pad
Dimensions: Product Depth	23 7/16" / 590 mm
Dimensions: Product Height	33 11/16" / 856 mm
Dimensions: Product Width	23 5/8" / 600 mm
Energy Consumption: Avg. Per Year	300 kWh
ENERGY STAR	No
Panel Height	14 15/16" / 379 mm
Panel Thickness	3/4" / 20 mm
Panel Type	Solid Panel
Panel Width	23 1/2" / 595 mm
Product Weight: Max	156 lbs
Refrigerant Type	R600a (1.41 oz)
Sabbath (Star K Certified)	Yes
Temperature Range	34°F - 45°F

COOLING SYSTEM

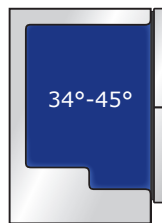

ELECTRICAL REQUIREMENTS

This unit requires a grounded, polarized 115 VAC, 60 Hz, 15 A power supply (normal household current).

